

Chronic Total Occlusion

Trials and Guidelines

Algorithm for crossing CTO from Asia Pacific CTO club

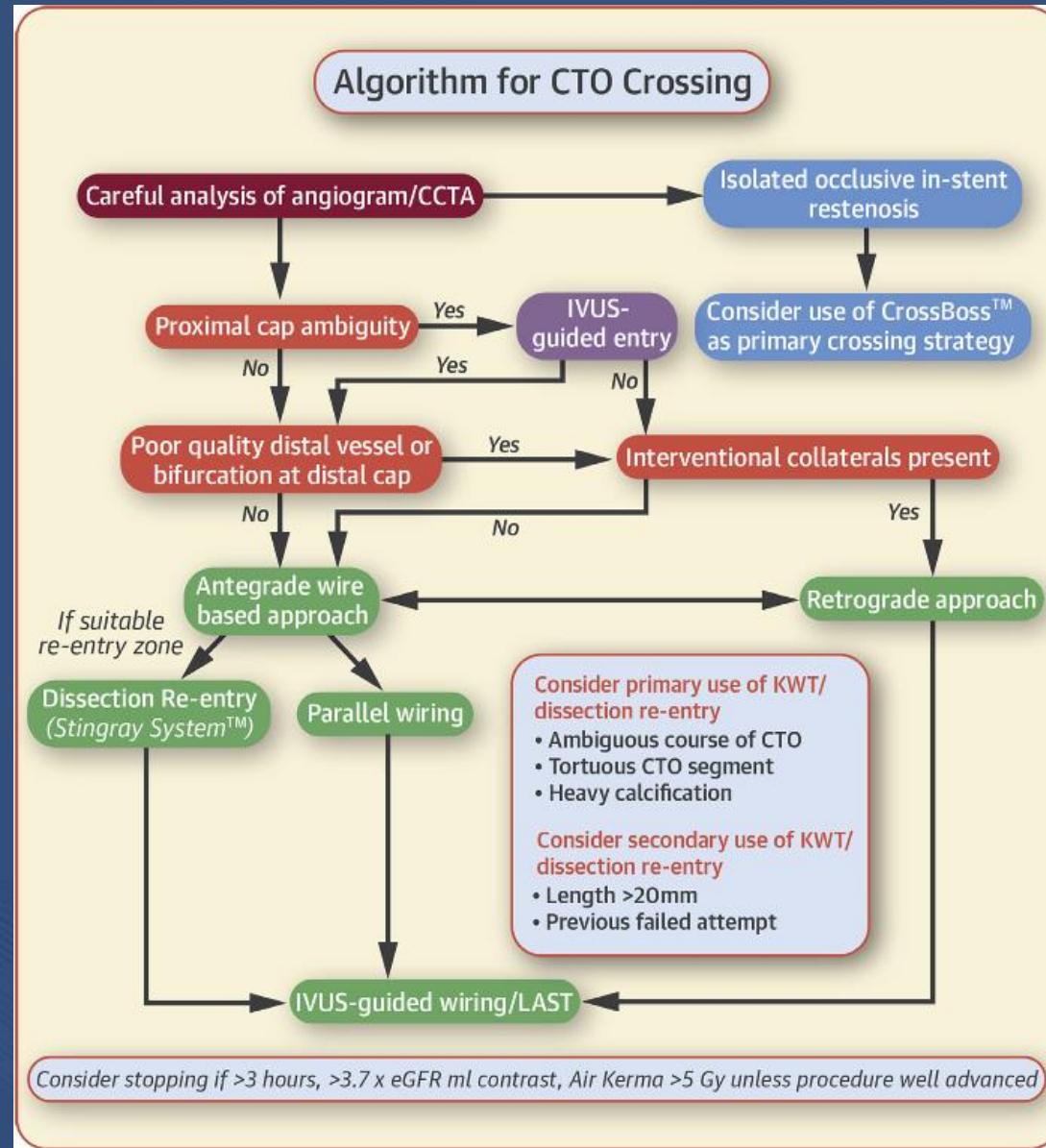

Algorithm for antegrade wire escalation

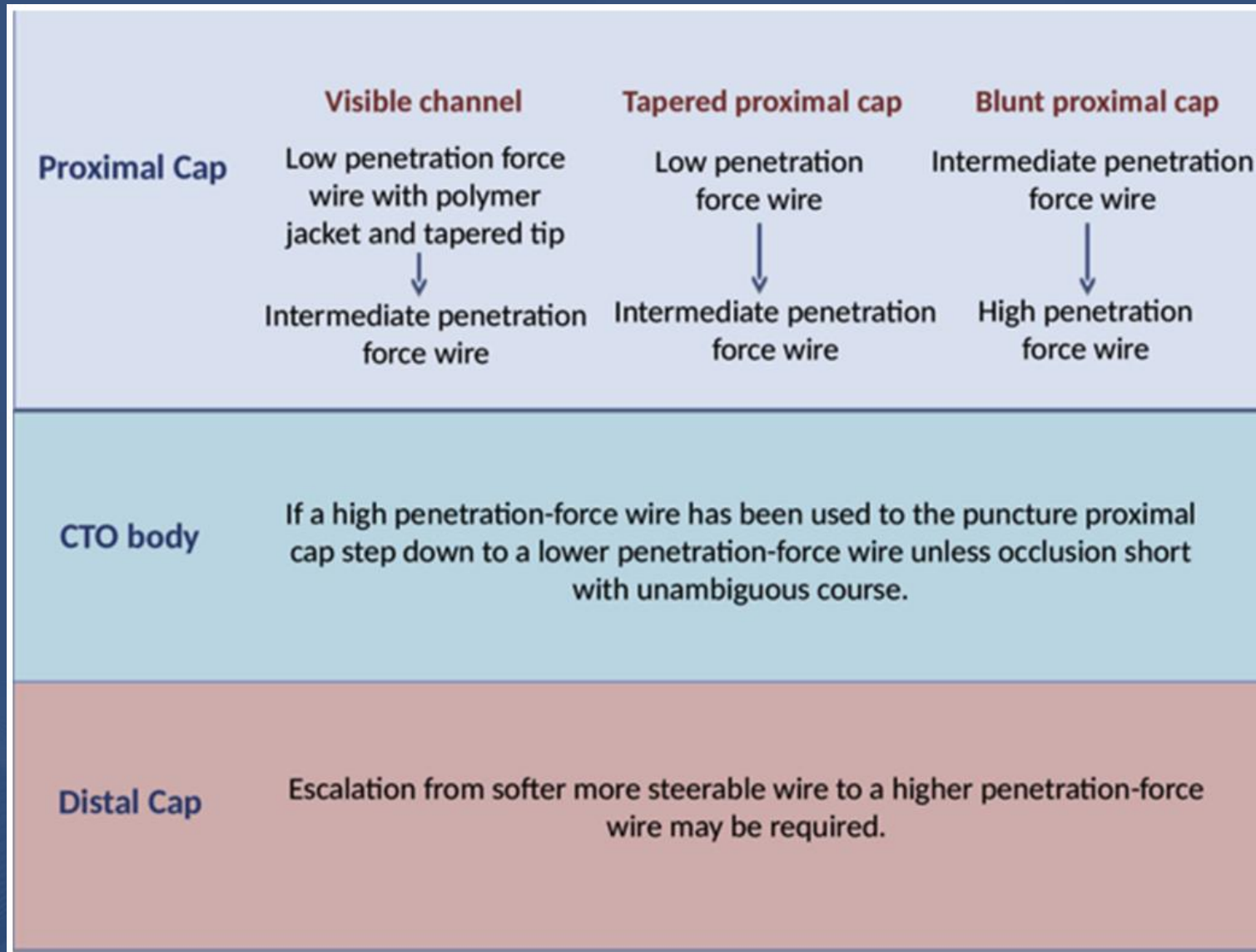

Coronary Artery CTO Revascularization Criteria

Chronic total occlusion of 1 major epicardial coronary artery, without other coronary stenoses		CCS angina class (*appropriate use score, 1-9)		
Noninvasive testing	Maximal anti-ischemic medication	ASx	I, II	III, IV
Low-risk findings	No	I(1)	I(2)	I(3)
	Yes	I(1)	U(4)	U(6)
Intermediate-risk findings	No	I(3)	U(4)	U(6)
	Yes	U(4)	U(5)	A(7)
High-risk findings	No	U(4)	U(5)	A(7)
	Yes	U(5)	A(7)	A(8)

* 1-3 : Inappropriate, 4-6 : Uncertain, 7-9 : Appropriate

DECISION-CTO

Patients with PCI-eligible CTO Lesions

1:1 randomization

PCI strategy

MT strategy

PCI for non-CTO lesions
+ PCI for CTO lesions

PCI for non-CTO lesions
+ **MT for CTO lesions**

Guideline Directed Medical Treatment

**Clinical Outcomes at 3 years
(Composite of Death, MI, Stroke and
any Revascularization)**

DECISION-CTO

Composite of Death, MI, Stroke and any Revascularization after 3-year

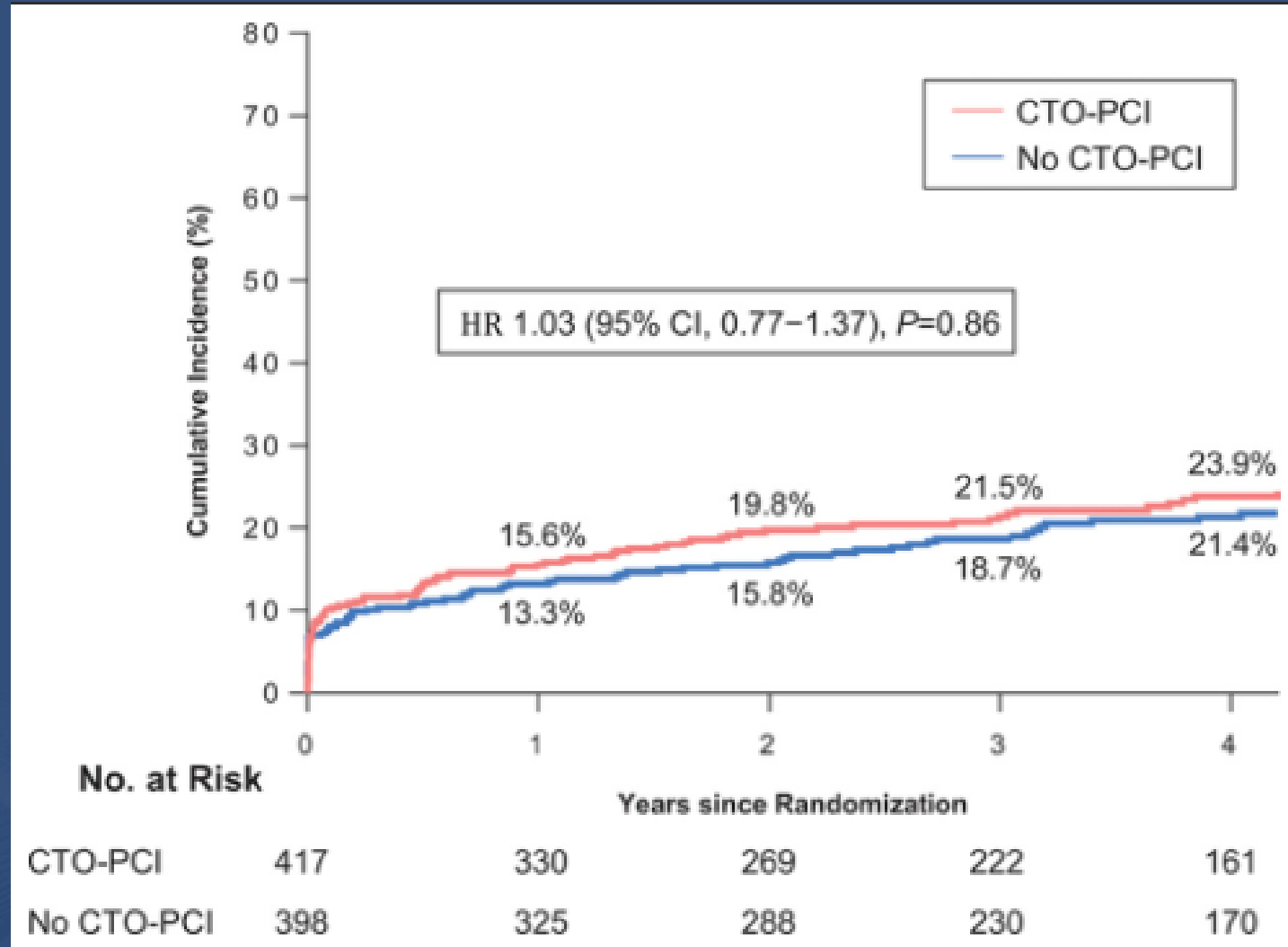

EURO-CTO

Patients with a CTO in an epicardial coronary artery > 2.5mm diameter and chronic stable angina with evidence of ischemia and viability in the territory subtended by the CTO

Biolimus-eluting stent

Optimal medical therapy

Primary Outcome at 3 years

1. Quality of Life : Seattle Angina Questionnaire and EQ-5D for health outcomes
2. Major Cardiovascular events : Cumulative composite endpoint of all-cause death, non-fatal MI

EURO-CTO: Study flowchart

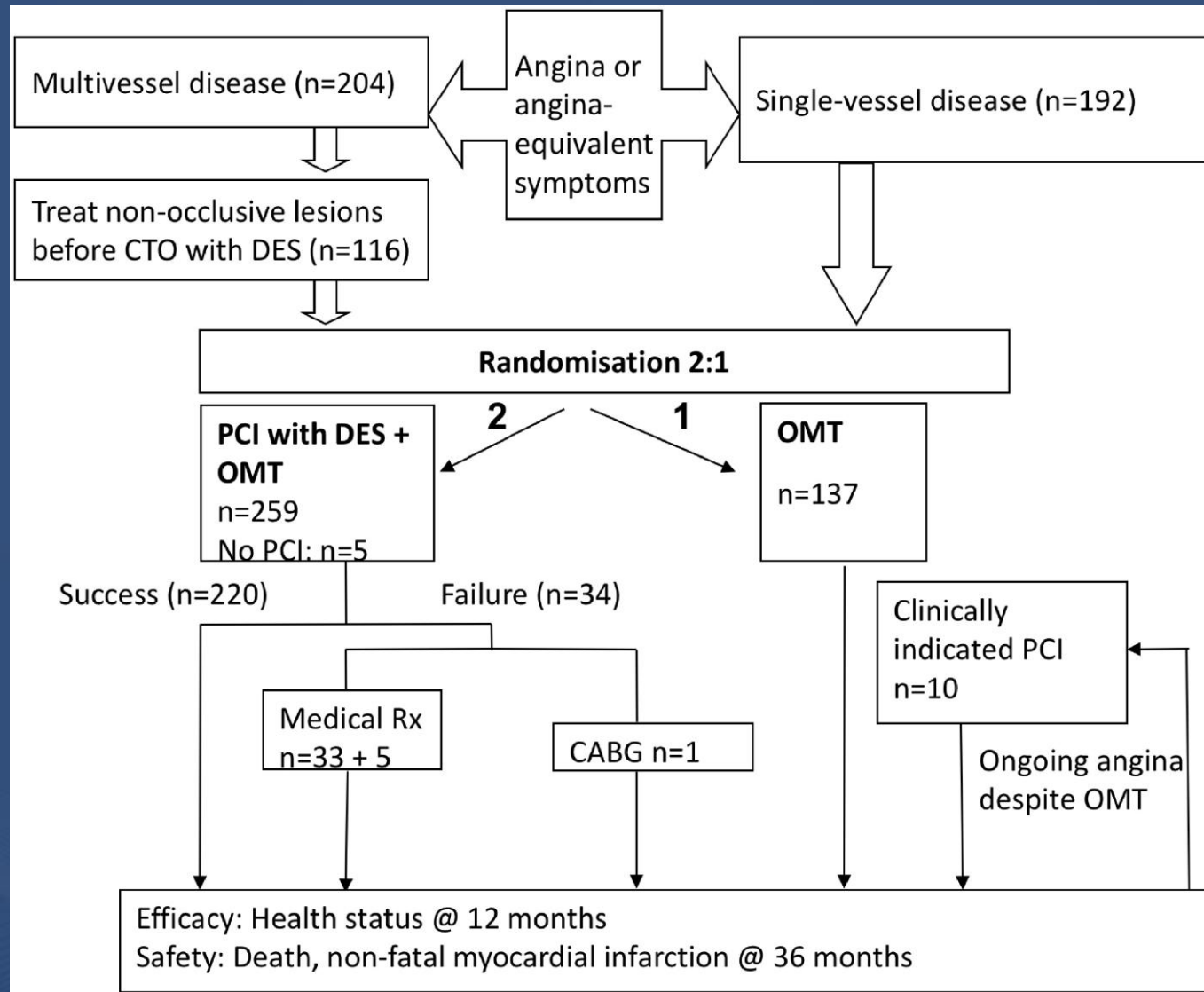

Quality of Life Measures

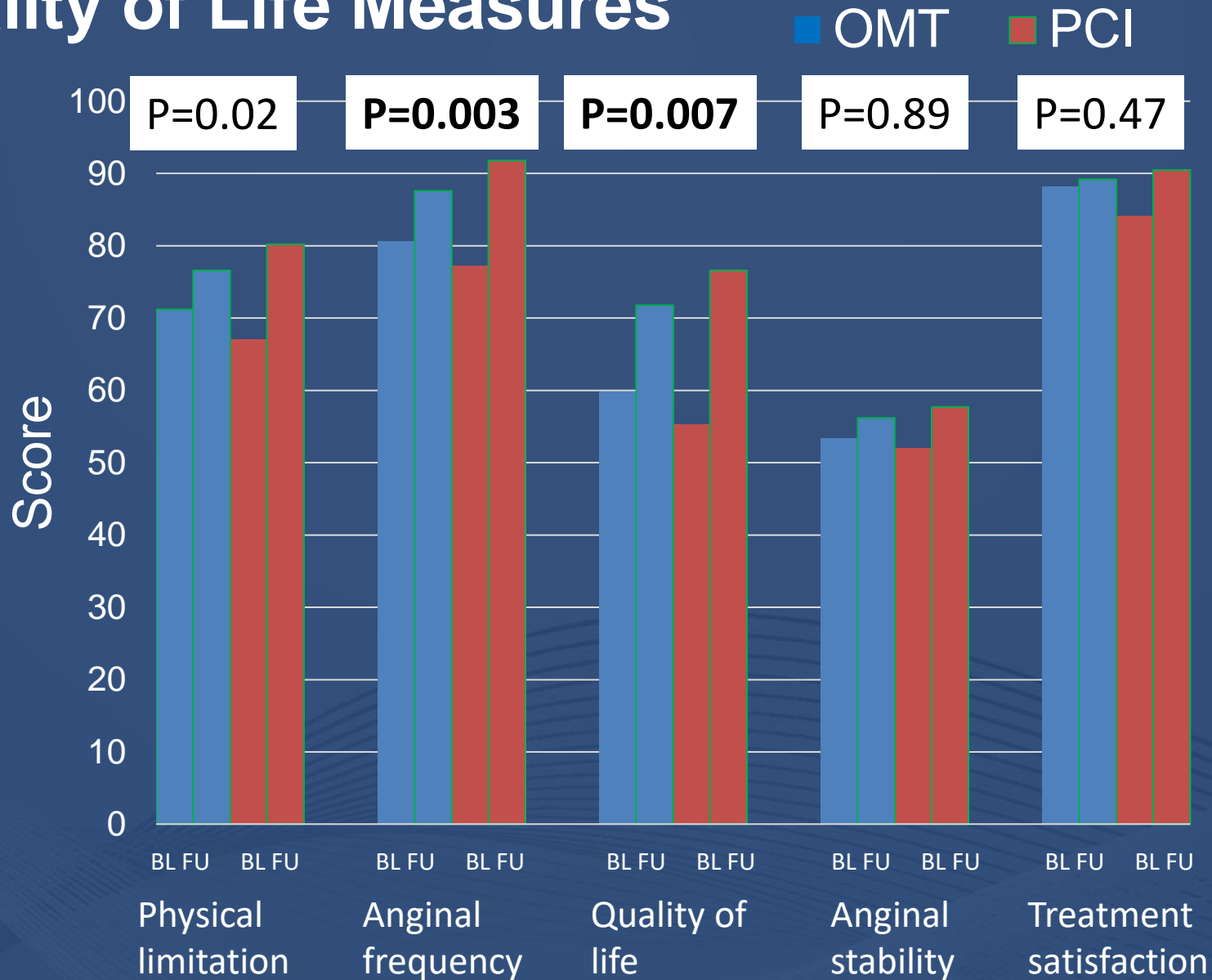

Primary safety endpoint at 36 months

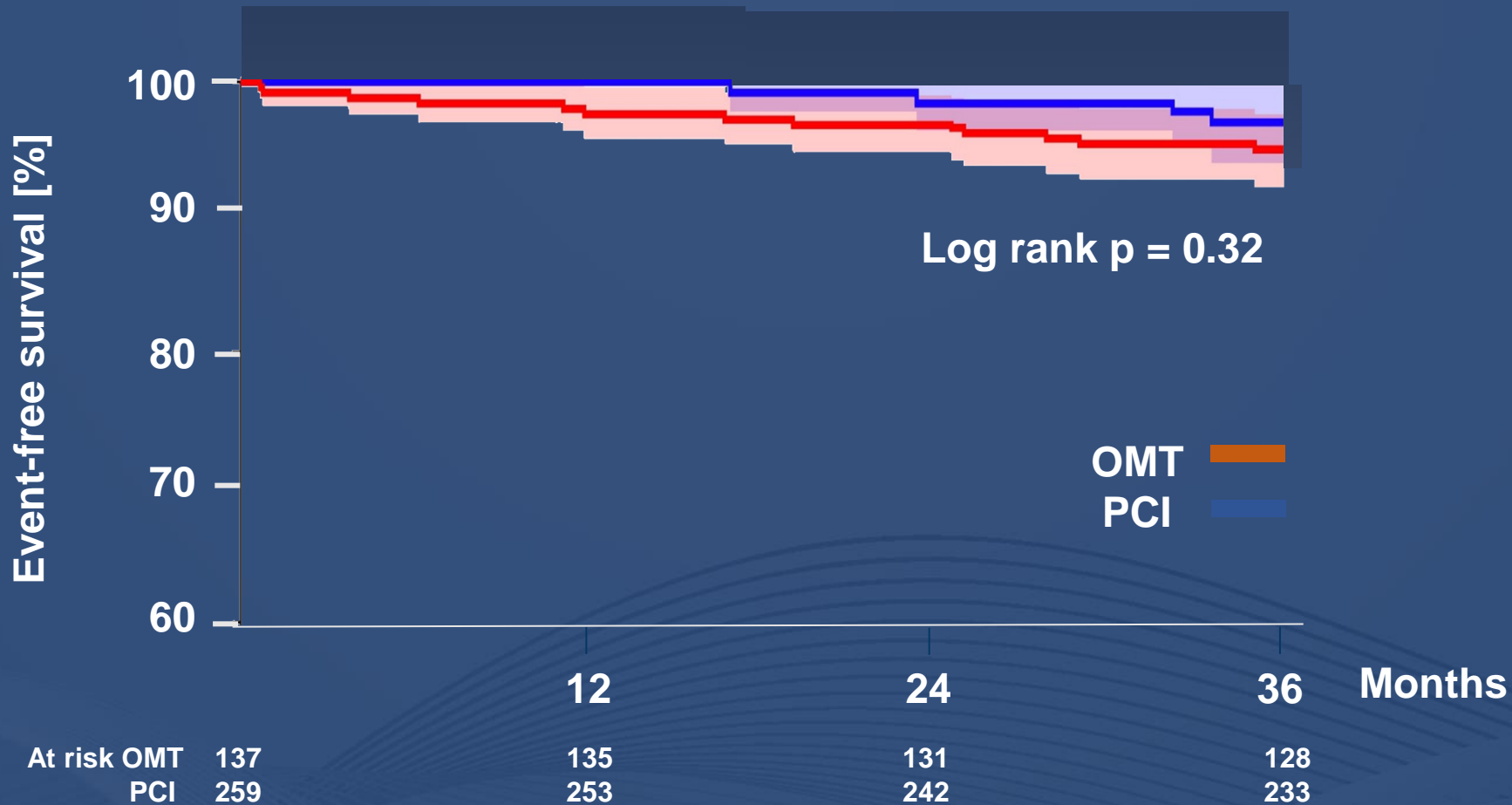

Primary safety endpoint at 36 months

	OMT (N=137)	PCI (N=259)	P (log rank)
Patients with any adverse event	27 (20.1)	27 (10.7)	0.019
Safety events	4 (2.9)	13 (5.0)	0.32
Cardiovascular death	2 (1.5)	7 (2.7)	0.42
Non-fatal MI	2 (1.5)	6 (2.3)	0.56
Ischemia-driven revascularization	25 (18.2)	19 (7.3)	0.0035
Target revascularization	23 (16.8)	10 (3.9)	0.0002
Cerebrovascular event	1 (0.7)	5 (1.9)	0.27
Stent thrombosis	0	1 (0.4)	

OPEN-CTO

Outcomes, Patient health status, and Efficiency in Chronic Total Occlusion hybrid procedures

1. Patients with at least one CTO vessel
2. 18 years and older
3. Patients is scheduled for a PCI for at least one CTO with TIMI antegrade flow of 0

- Investigator-initiated multicenter, single-arm registry (12 centers with 1000 patients)

- Observational study
- Hybrid approach

- 1, 6 and 12 month outcomes
1. Health status
2. Resource use
3. Depression
4. Rehospitalization
5. Survival
6. Cost

OPEN-CTO

Health Status Trajectory after CTO-PCI

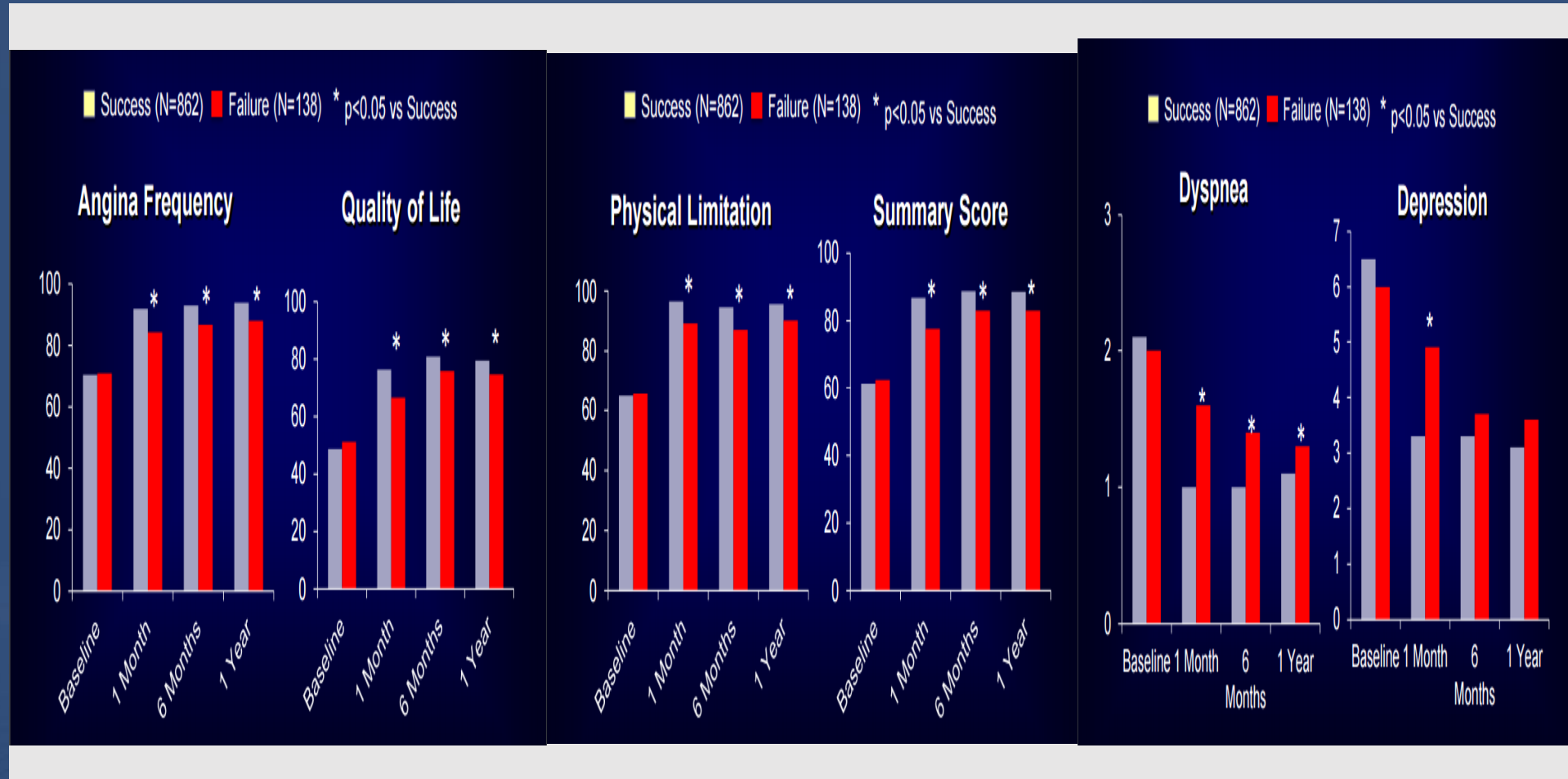

OPEN-CTO

Health Status Trajectory after CTO-PCI

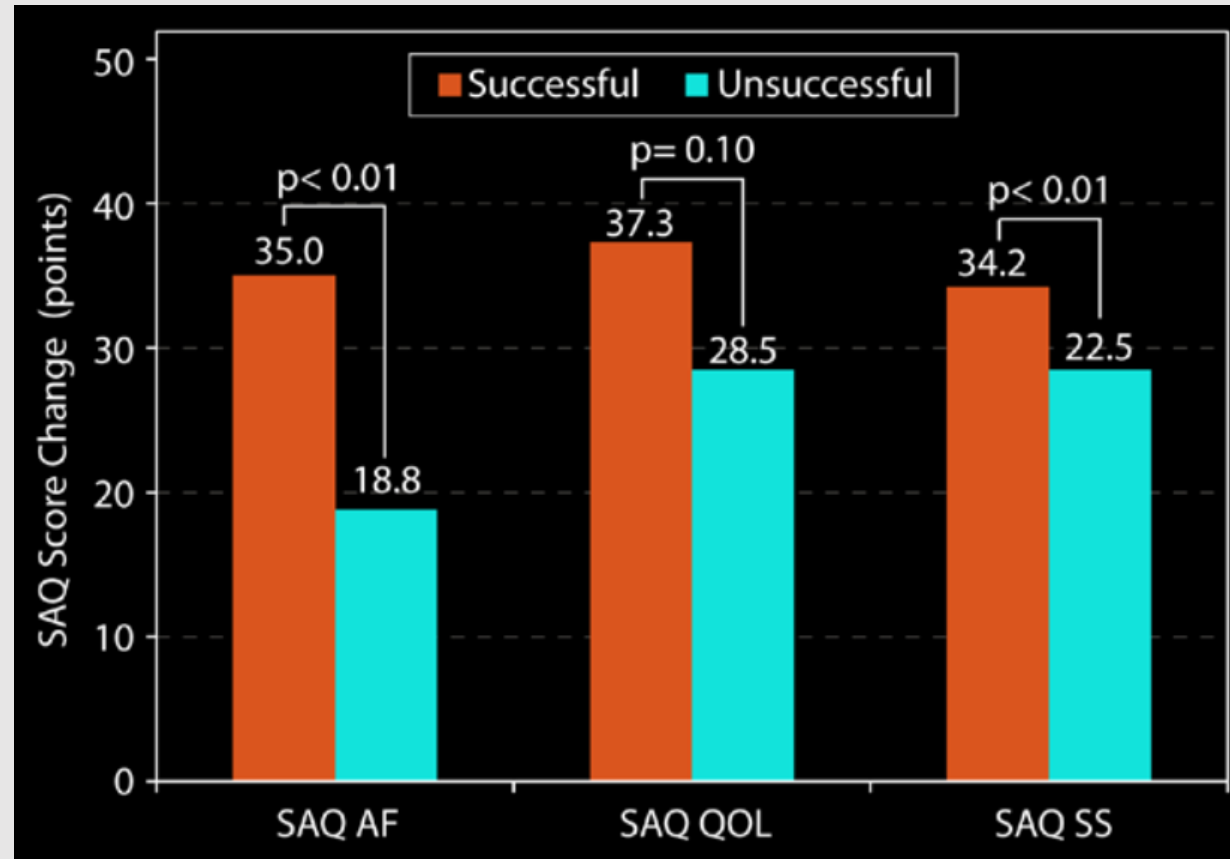

PROGRESS CTO score

Proximal cap ambiguity
(1 point)



Poor cap visualization or absence of clearly tapered stump

Absence of “interventional” collaterals
(1 point)

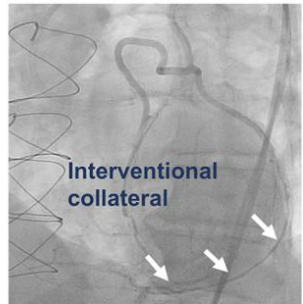

Interventional collateral

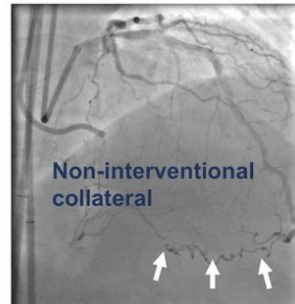

Non-interventional collateral

Moderate/severe tortuosity
(1 point)

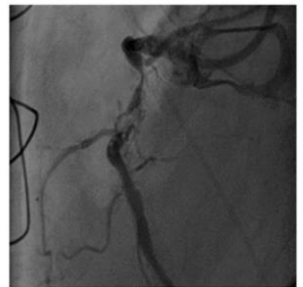

2 bends > 70 degrees or 1 bend > 90 degrees

Circumflex CTO
(1 point)

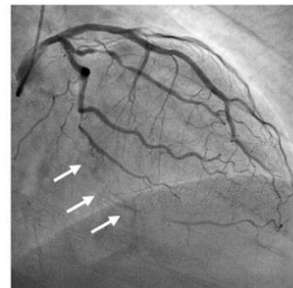

(PROGRESS CTO) Complications Score

The PROGRESS CTO complication score is a useful tool for prediction of periprocedural complications in CTO PCI.

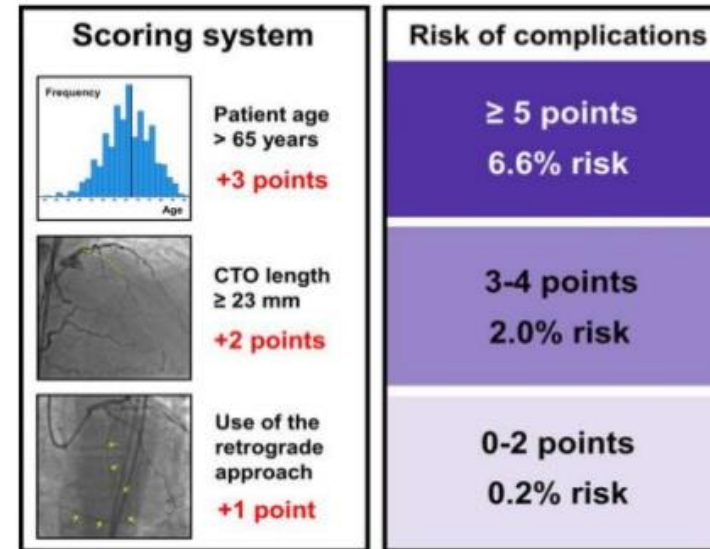

Danek BA, Karatasakis A et al J Am Heart Assoc. 2016;5:e004272

Christopoulos et al. JACC Cardiovasc Interv. 2016 Jan 11;9(1):1-9.

REVASC

Recovery of Left Ventricular Function in Coronary Chronic Total Occlusion

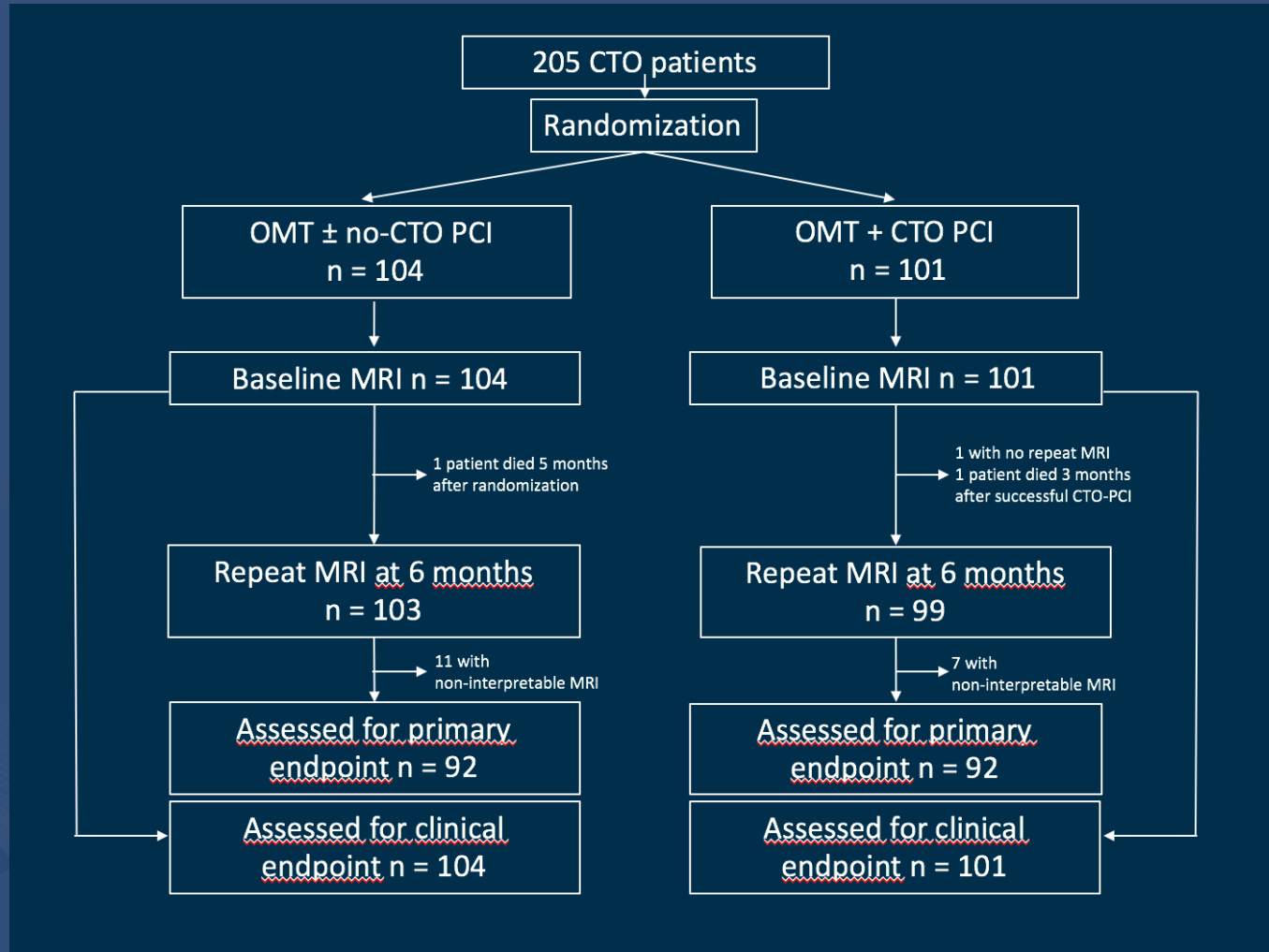

REVASC

Primary end point

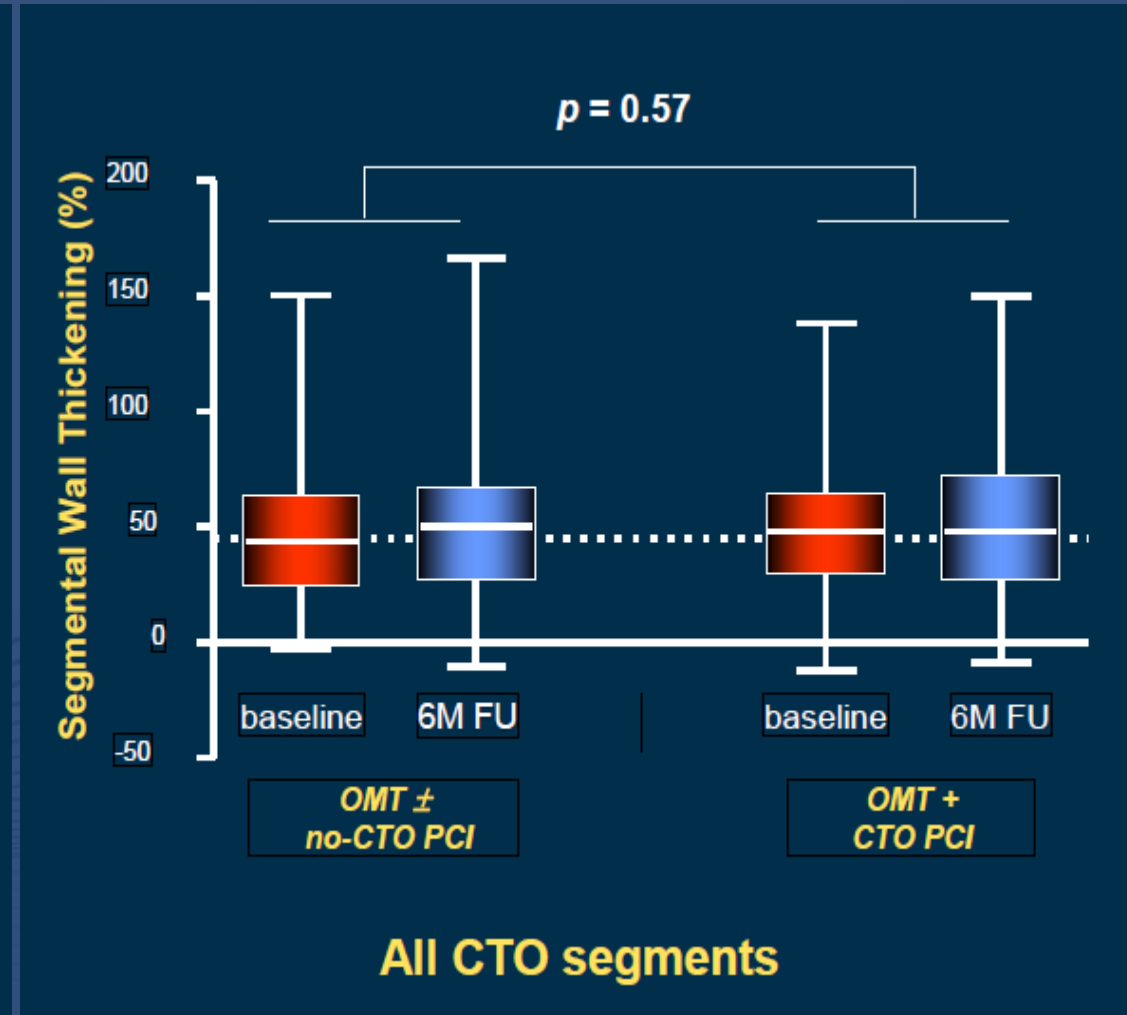
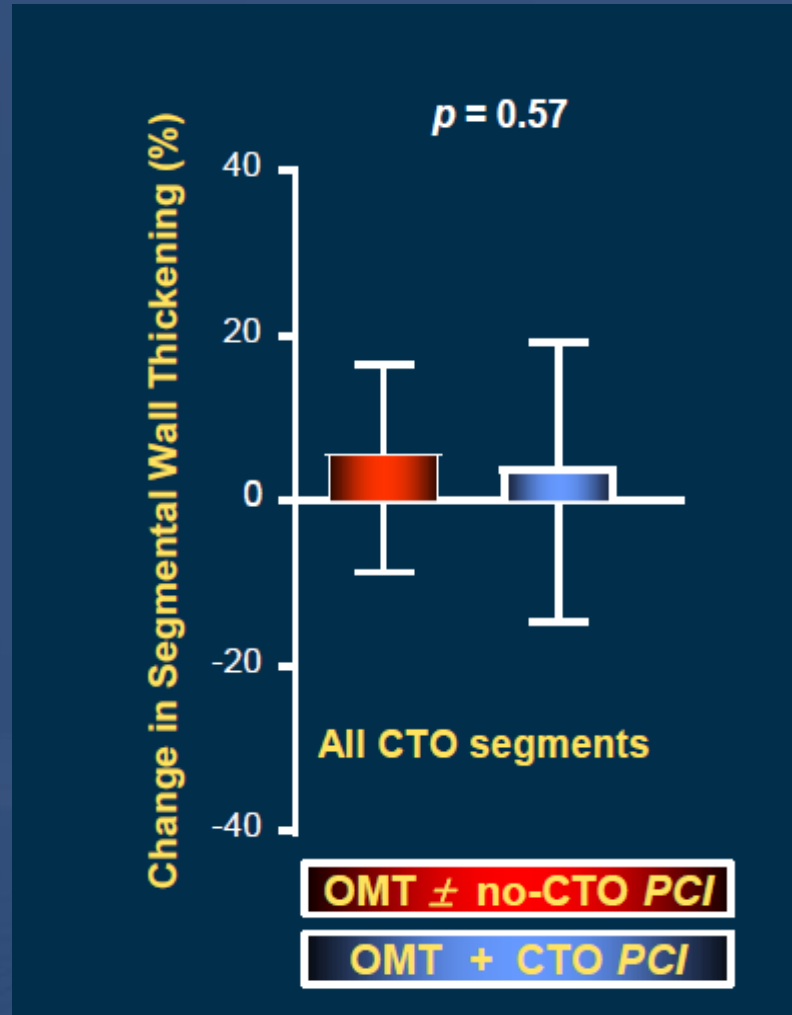

EXPLORE: MRI-Assessed LVEF at 4 months

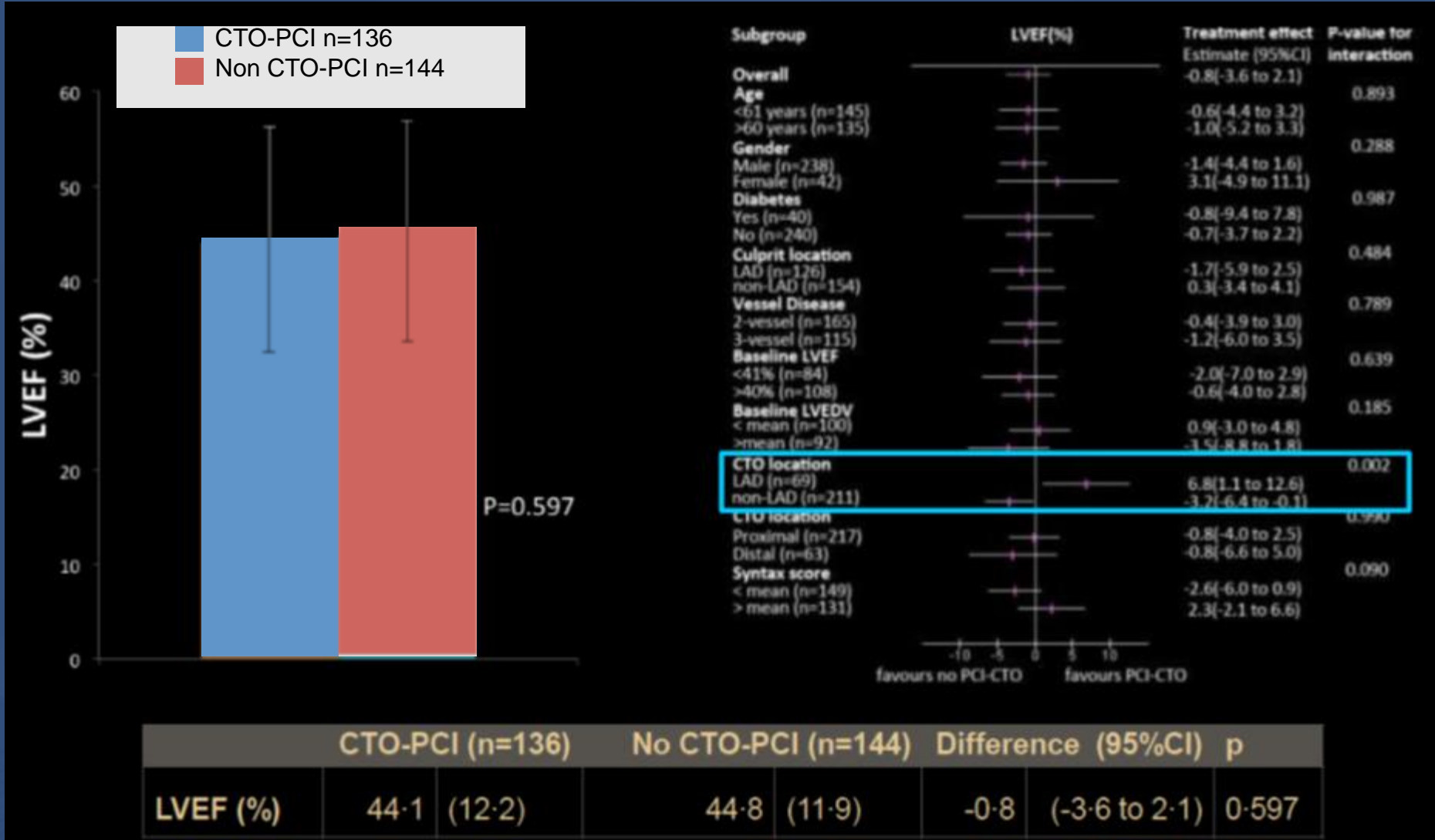

Impact of CTO on Outcomes: BARI 2D

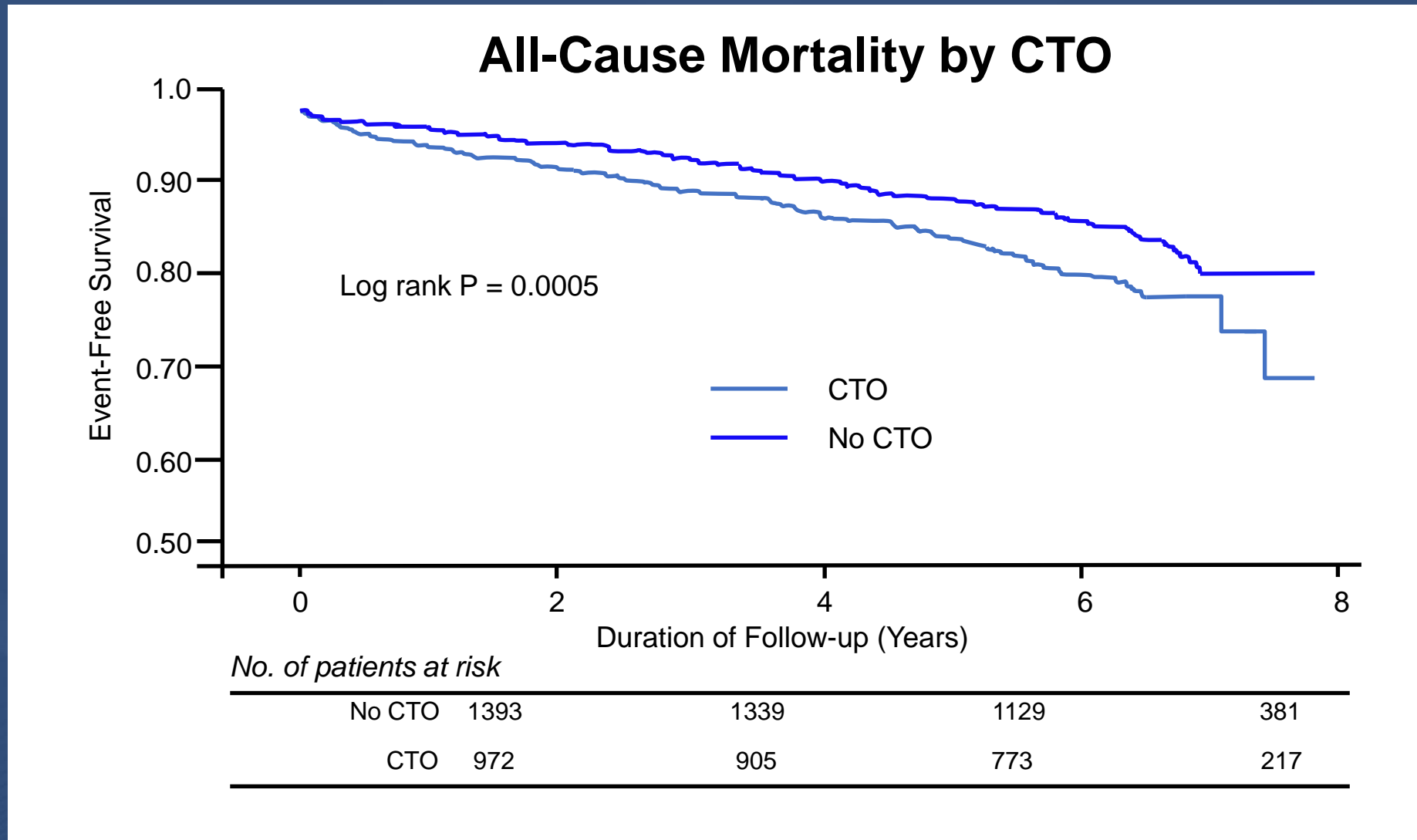

Impact of OMT after Failed vs. Successful CTO-PCI

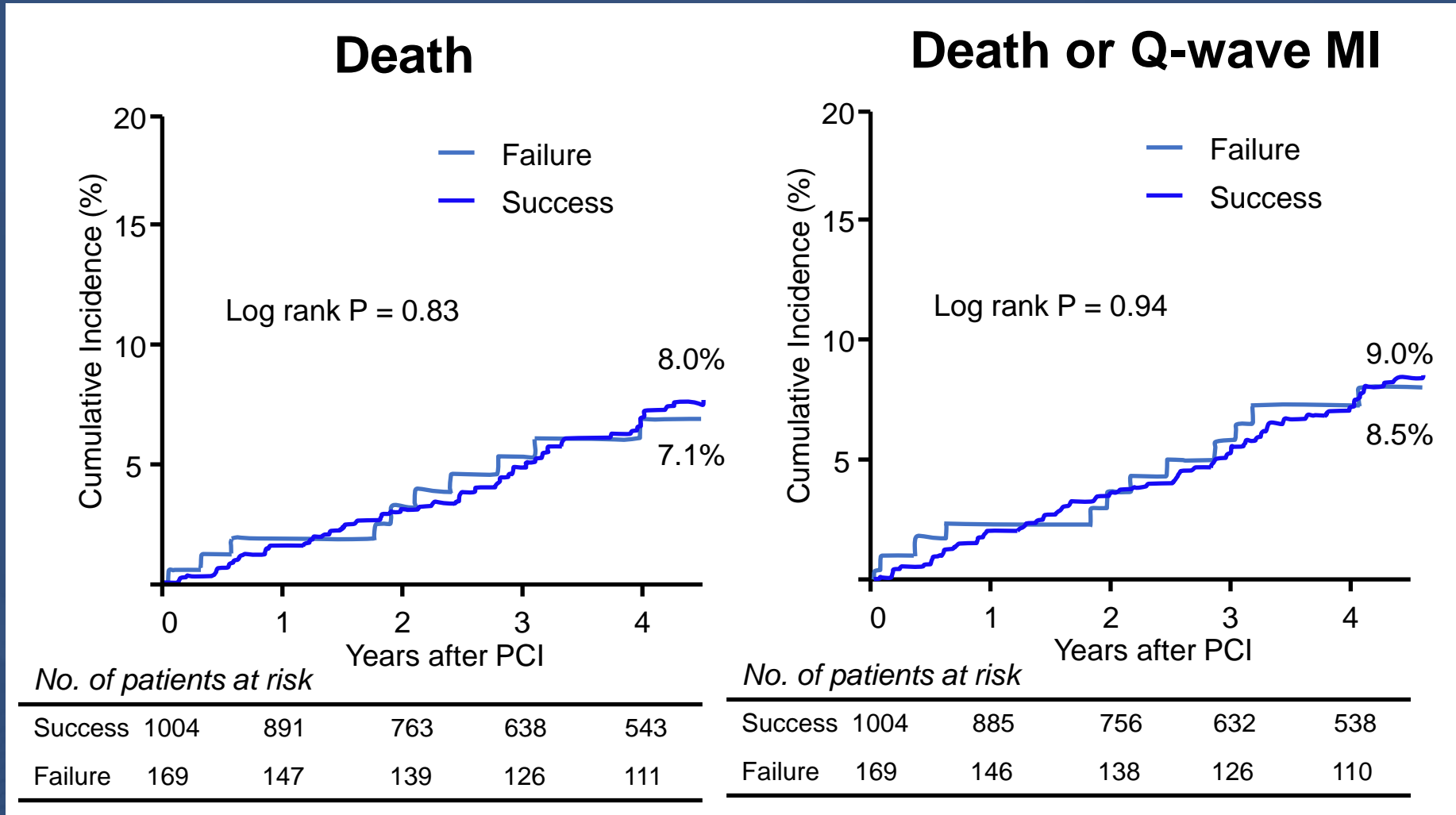

PH Lee et al, J Am Coll Cardiol Intv 2016;9:530–8

Impact of OMT after Failed vs. Successful CTO-PCI

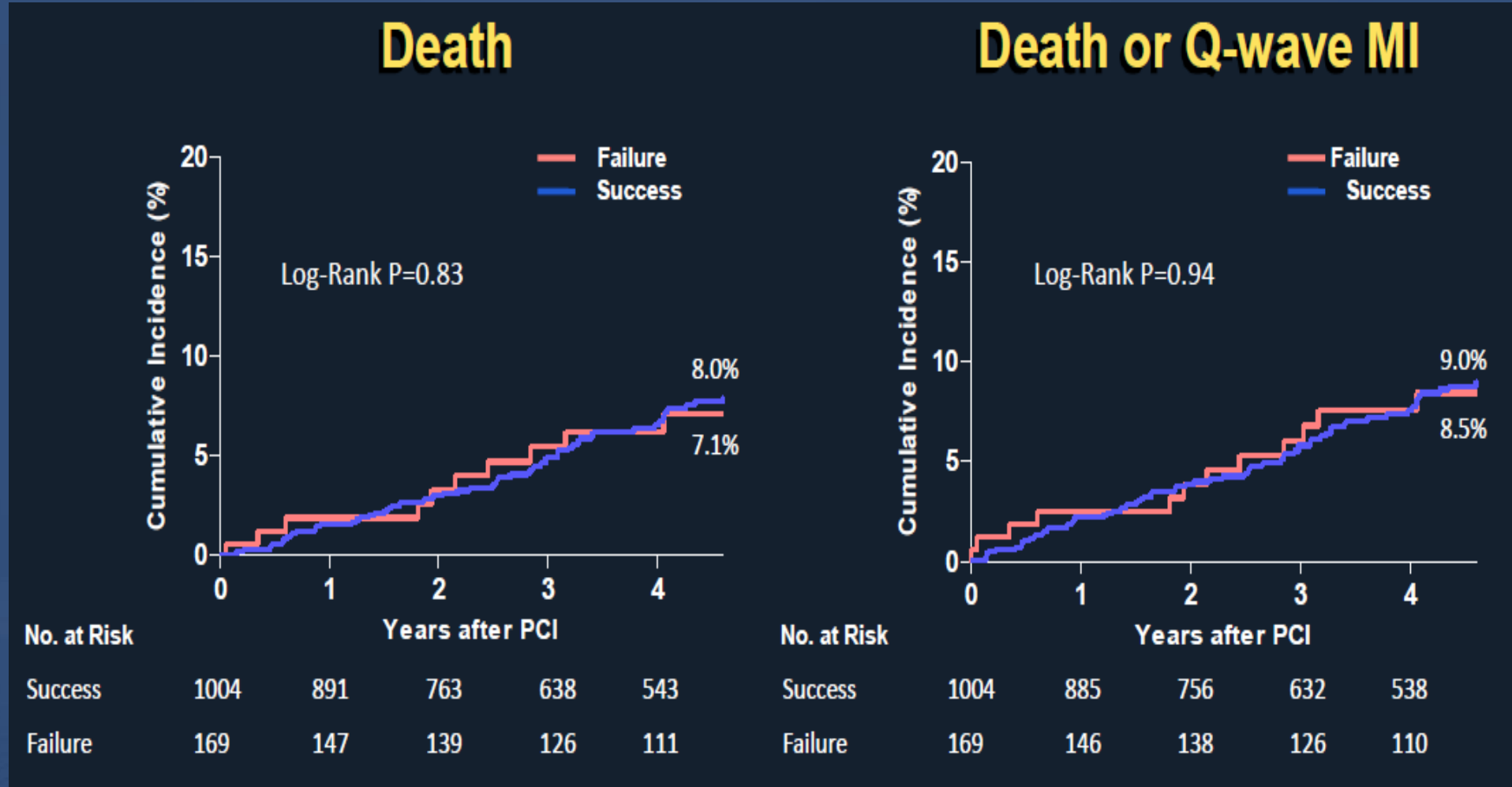

PH Lee et al, J Am Coll Cardiol Intv 2016;9:530-8

AD Hoc vs Planned CTO-PCI

Technical success (%) according to J-CTO

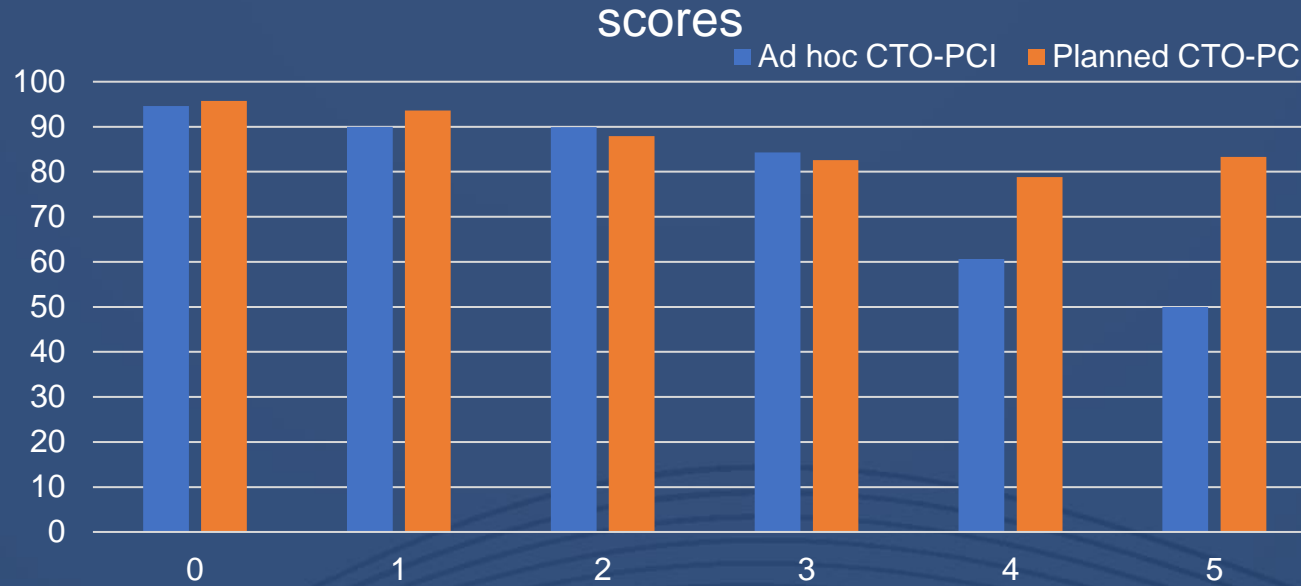

Ad hoc CTO-PCI	94.6%	90.0%	89.9%	84.3%	60.6%	50.0%
Planned CTO PCI	95.7%	93.6%	87.9%	82.6%	78.8%	83.3%
Cases (n)	167	374	507	616	420	106

Multivariable analysis for technical success

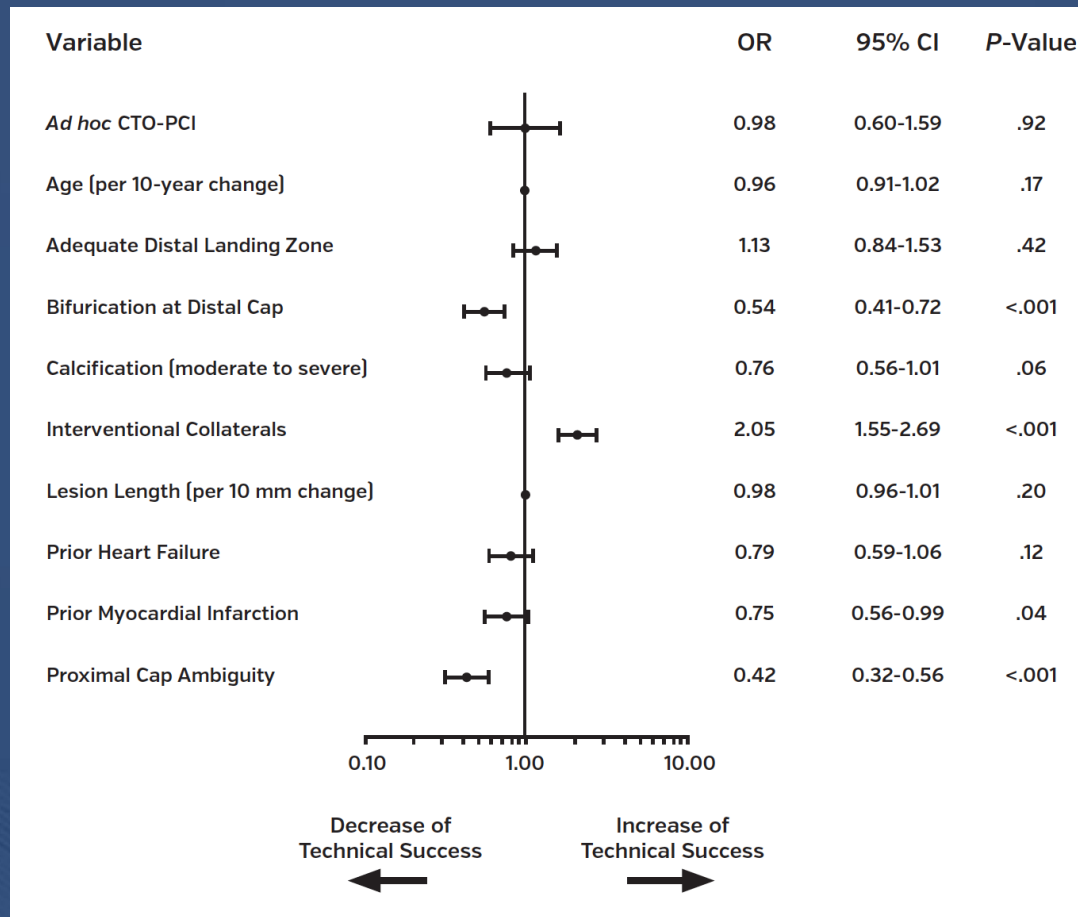

Retrograde approach for CTO-PCI

Technical and procedural success rates

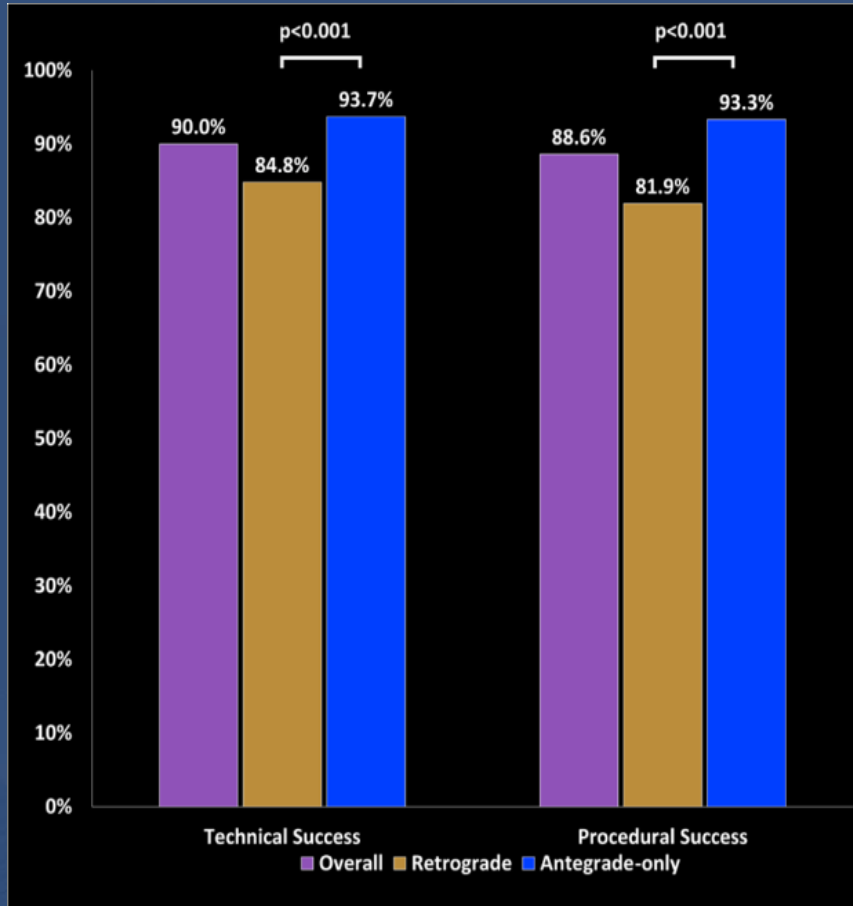

Incidence of In-hospital MACE

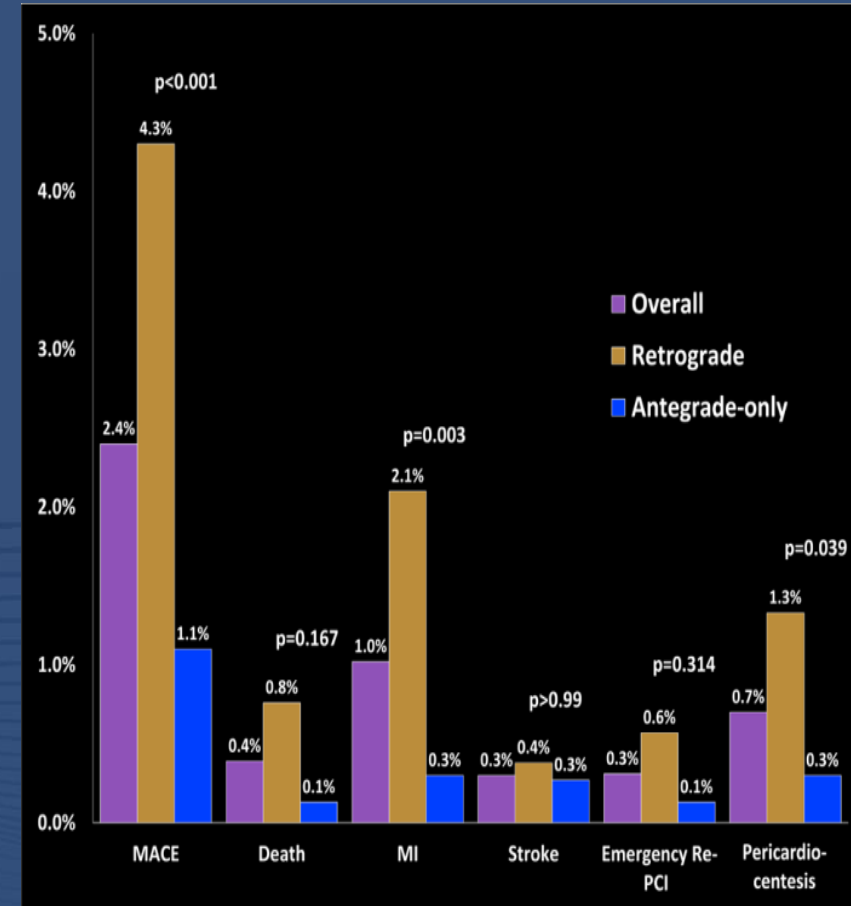

Dimitri K et al, *Circ Cardiovasc Interv.* 2016;9:e003434.

COMET-CTO

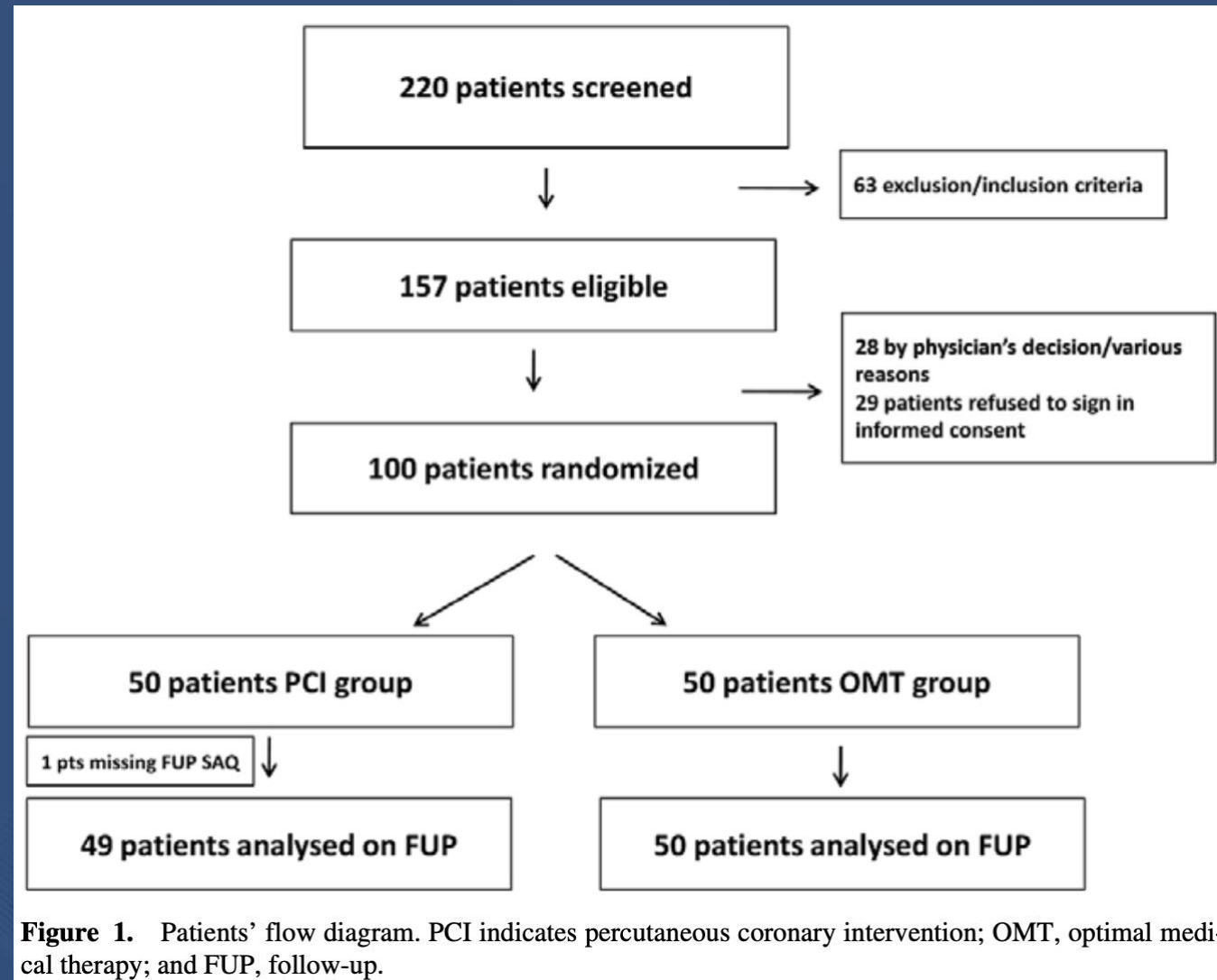

Figure 1. Patients' flow diagram. PCI indicates percutaneous coronary intervention; OMT, optimal medical therapy; and FUP, follow-up.

COMET-CTO

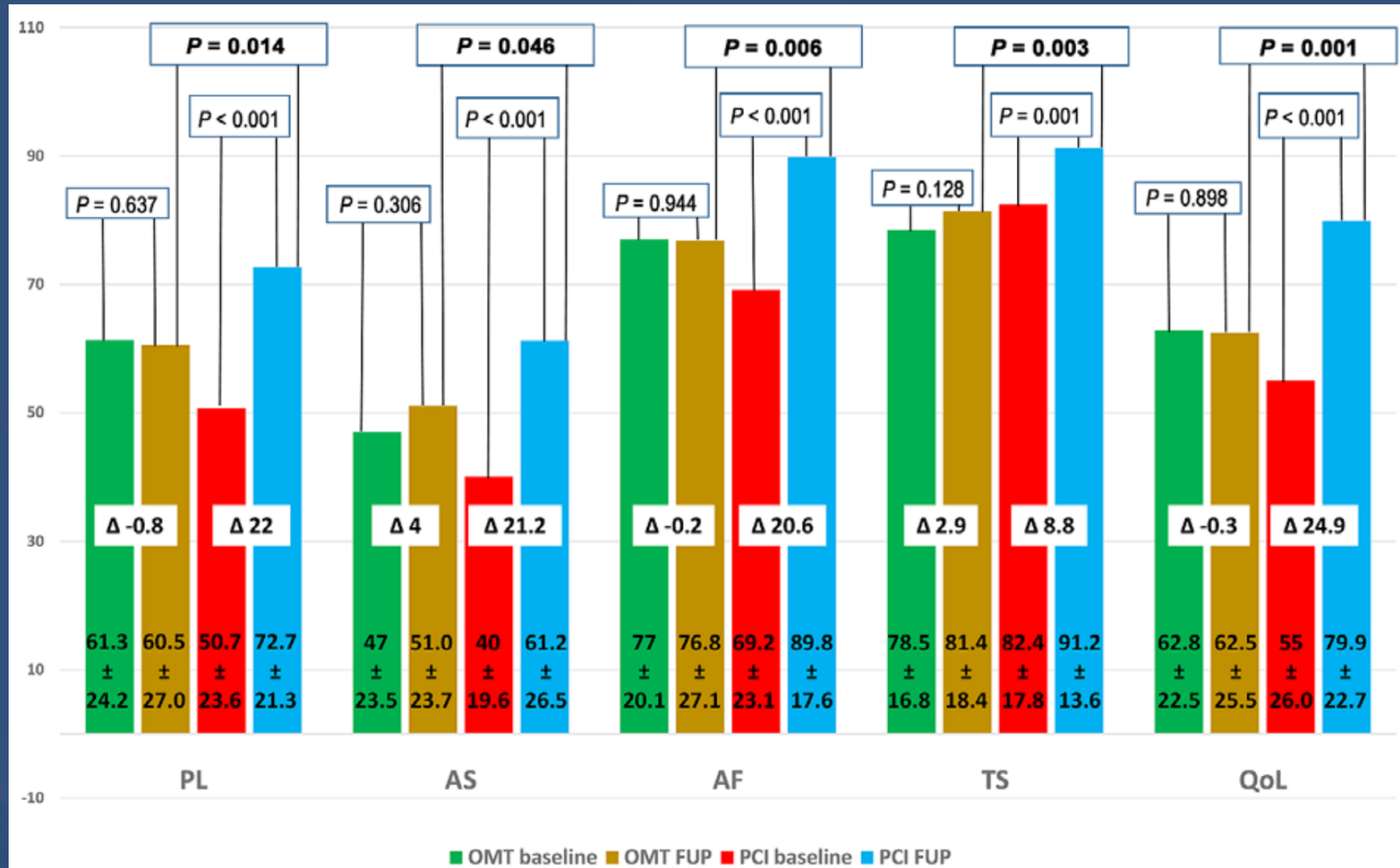

Figure 2. SAQ subscale changes. QoL indicates quality of life; PL, physical limitation; AS, angina stability; AF, angina frequency; TS, treatment satisfaction; PCI, percutaneous coronary intervention; OMT, optimal medical therapy; and FUP, follow-up. Δ: difference between f-up and baseline mean values.

Canadian Multicenter Chronic Total Occlusion Registry:

Ten-Year Follow-Up Results of Chronic Total occlusion Revascularization

- The primary data source from Canadian Multicenter CTO registry (2008.4 ~ 2009.7)
- Revascularization decisions were determined by local routine care

•All PCIs were performed in 3 centers

•Prospective multicenter cohort study
•Revascularization group was divided into CTO revasc vs no CTO revasc

- Primary outcome
 - All-cause mortality
- Secondary outcomes
 - Hospitalizations for ACS or HF
 - Revascularization, a composite of TVR or non-TVR beyond 90 days post index procedure

All-cause mortality

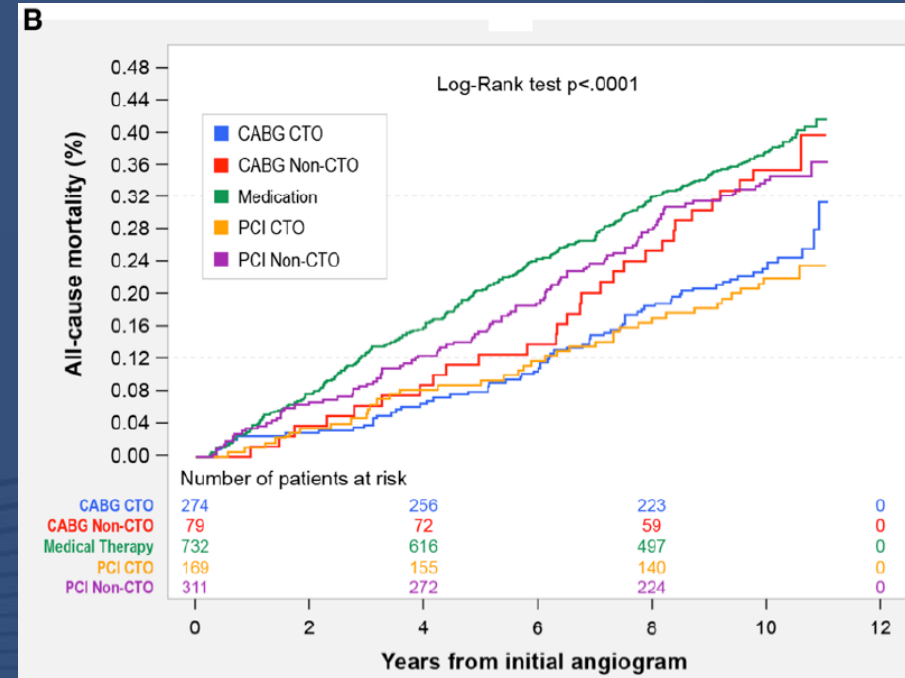
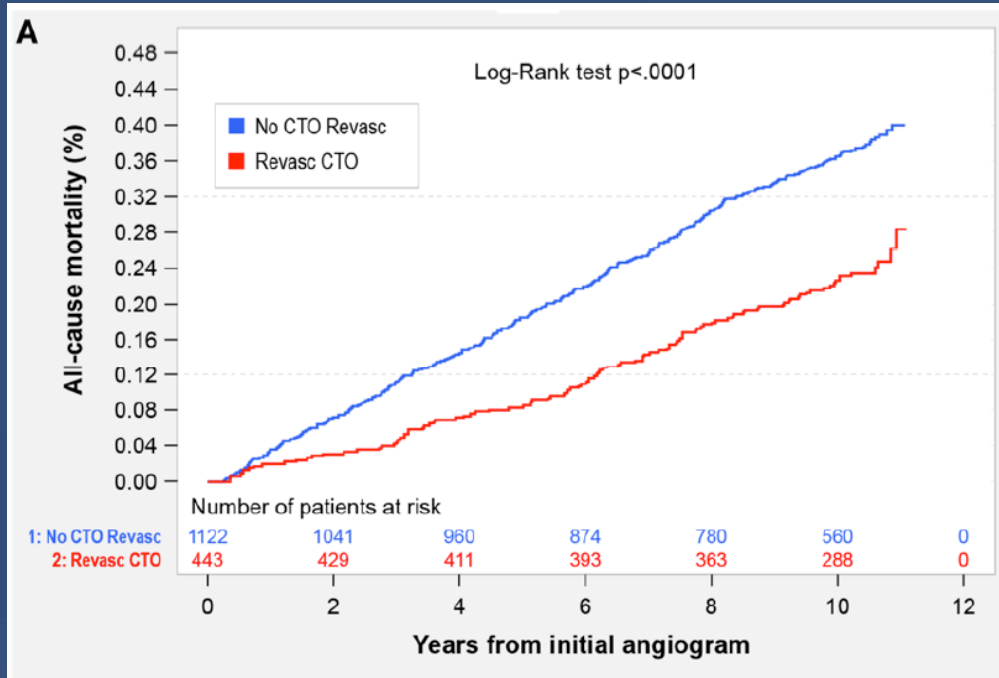

Adverse clinical events at 10 years

Adverse outcome	Total	CTO revasc (n=458)	No CTO revasc (n=1166)
Mortality, %	32.6 (30.3-35.0)	22.7 (19.0-26.9)	36.6 (33.8-39.5)
Revasc (PCI), %	10.6 (9.2-12.2)	11.1 (8.4-14.2)	10.5 (8.8-12.4)
Revasc (CABG), %	11.1 (18.3-22.3)	3.6 (2.2-5.7)	14.0 (12.1-16.1)
Revasc (PCI/CABG), %	20.3 (18.3-22.3)	14.0 (11.0-17.4)	22.8 (20.4-25.3)
Hospital (ACS), %	14.7 (12.9-16.5)	10.0 (7.4-13.1)	16.6 (14.4-18.9)
Hospital (HF), %	11.9 (10.3-13.6)	9.6 (7.0-12.6)	12.8 (10.9-14.8)

Cumulative incidence of later revascularization

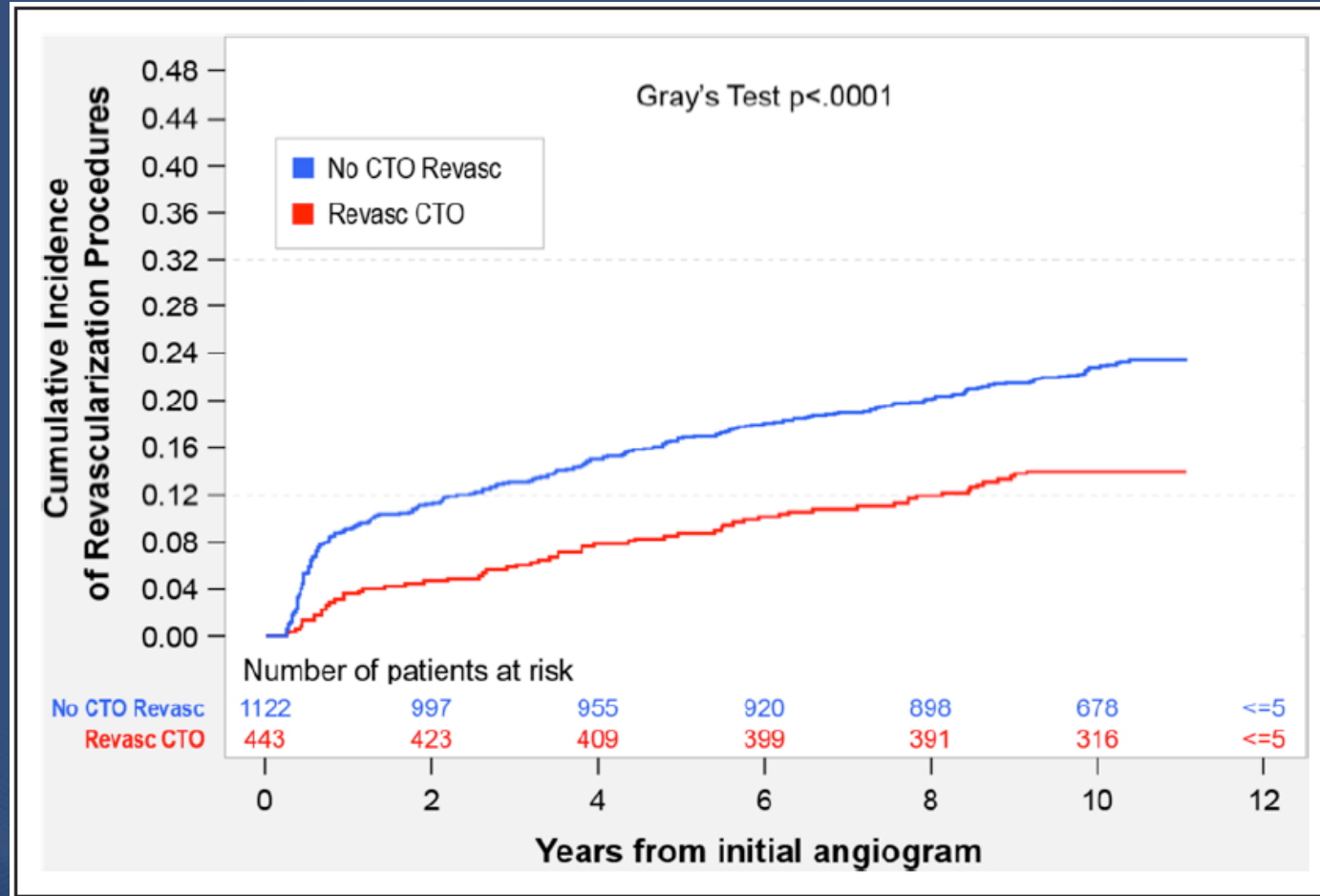

Cumulative incidence of ACS hospitalization

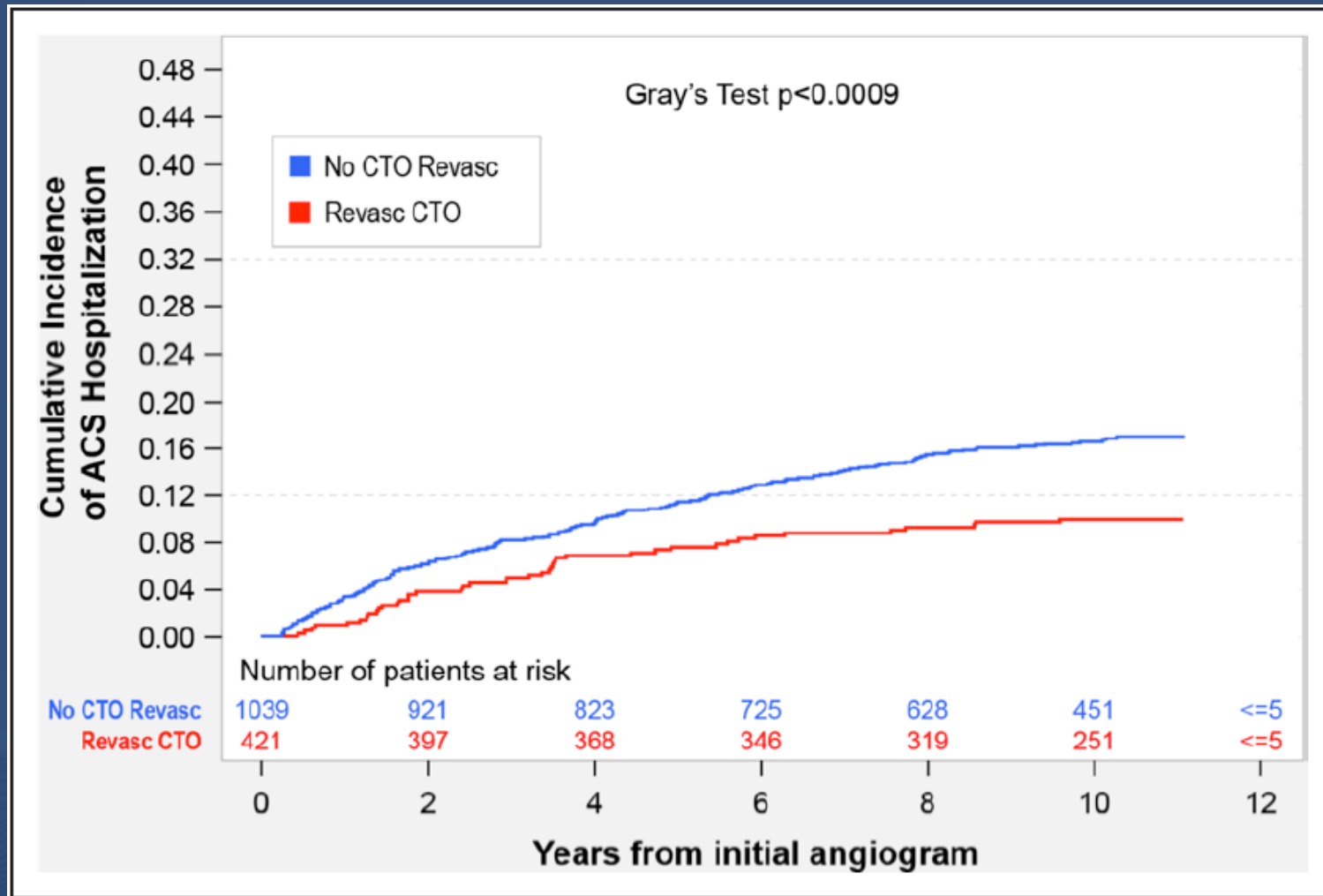

Periprocedural Risk Prediction Scores in CTO

- Studies included (5 publications) with 8 CTO PCI specific scores (to October 26, 2022)

- (1) Angiographic coronary artery perforation
- (2) Major adverse cardiovascular events (MACE)
- (3) All-cause mortality
- (4) Perforation requiring pericardiocentesis
- (5) Acute myocardial infarction
- (6) Perforation requiring any treatment
- (7) Contrast-induced acute kidney injury

PROGRESS-CTO complication scores and the

CTO PCI complication scores	Events	Variables	Points assigned	Risk score, complication risk
PROGRESS-CTO complications score (score range: 0–6)	n = 44 (2.8%) MACE: composite of death, MI, stroke, urgent repeat revascularization (re-PCI or surgery), or pericardiocentesis	Age >65 years Lesion length ≥23 mm Retrograde strategy	+ 3 + 2 + 1	0–2, 0.2% 3–4, 2.0% ≥5, 6.6%
OPEN-CLEAN perforation score (score range: 0–7)	n = 89 (8.9%) angiographic perforation	Prior CABG Occlusion length 20–59 mm ≥60 mm LVEF <50% Age: 50–<70 years ≥70 years Calcification	+ 1 + 1 + 2 + 1 + 1 + 2 + 1	0–1, 2.2% 2, 3.3% 3, 4.4% 4, 8.2% 5, 14.9% 6–7, 30.9%
PROGRESS-CTO MACE (score range: 0–7)	n = 215 (2.05%) MACE: composite of death, MI, stroke, urgent repeat revascularization (re-PCI or surgery), or pericardiocentesis	Age ≥65 years Female gender Moderate-severe calcification Blunt/no stump Antegrade dissection and re-entry Retrograde strategy	+ 1 + 2 + 1 + 1 + 1 + 2	0, 0.4% 1, 0.7–0.9% 2, 1.1–1.9% 3, 1.6–2.6% 4, 2.6–4.7% 5, 4.4–6.1% 6, 7.2–9.3% 7, 11.7%
PROGRESS-CTO Mortality (score range: 0–4)	n = 47 (0.45%) all-cause mortality	Age ≥65 years Moderate-severe calcification LVEF ≤45% Antegrade dissection and re-entry Retrograde strategy	+ 1 + 1 + 1 + 1 + 1	0, 0.05% 1, 0.1–0.2% 2, 0.3–0.5% 3, 0.5–1.1% 4, 1.9–2.4%

PROGRESS-CTO complication scores and the

CTO PCI complication scores	Events	Variables	Points assigned	Risk score, complication risk
PROGRESS-CTO pericardiocentesis (score range: 0–5)	n = 83 (1.08%) perforation requiring pericardiocentesis	Age ≥65 years Moderate-severe calcification Female gender Antegrade dissection and re-entry Retrograde strategy	+ 1 + 1 + 1 + 1	0, 0.2% 1, 0.4–0.6% 2, 0.6–1.6% 3, 1.3–3.6% 4, 2.8–7.2% 5, 8.7%
PROGRESS-CTO Acute MI (score range: 0–3)	n = 66 (0.63%) acute MI	Prior CABG Atrial fibrillation Blunt/no stump	+2 + 1 + 1 + 1	0, 0.2 1, 0.4–0.5% 2, 1.1–1.2% 3, 2.8%
PROGRESS-CTO perforation score (score range: 0–5)	n = 503 (4.9%) perforation requiring any treatment	Age ≥65 years Moderate-severe calcification Blunt/no stump Antegrade dissection and re-entry Retrograde strategy	+ 1 + 1 + 1 + 1 + 2	0, 0.7% 1, 0.9–1.6% 2, 1.7–2.9% 3, 3.0–5.0% 4, 6.4–8.0% 5, 11%
Contrast-induced acute kidney injury score* (score range: 0–16)	n = 17 (2.7%) absolute increase in serum creatinine of ≥0.5 mg/100 ml over baseline values within 48–72 h after contrast exposure	Age ≥75 years LVEF <40% Serum creatinine >1.5 mg/100 ml Serum albumin (g/L) ≤30 >30–40 >40	+ 4.5 + 3.5 5 + 2 + 1 0	<4, 0–0.8% 4–7, 5.3%–8.2% ≥7, 13–31%

CTO PCI-specific periprocedural complication risk scores

CTO PCI Complication Scores	Risk Score, Complication Risk
PROGRESS-CTO complications score	0–2 (low risk) 3–4 (moderate risk) ≥5 (high risk)
OPEN-CLEAN perforation score	0–2 (low risk) 3–4 (moderate risk) 5–7 (high risk)
PROGRESS-CTO MACE	0–2 (low risk) 3–4 (moderate risk) 5–7 (high risk)
PROGRESS-CTO mortality	0 (low risk) 1–2 (moderate risk) 3–4 (high risk)
PROGRESS-CTO pericardiocentesis	01 (low risk) 2–3 (moderate risk) 4–5 (high risk)
PROGRESS-CTO acute MI	01 (low risk) 2 (moderate risk) 3 (high risk)
PROGRESS-CTO perforation score	01 (low risk) 2–3 (moderate risk) 4–5 (high)
Contrast-induced acute kidney injury score	<4, (low risk) 4–6 (moderate risk) ≥7, (high risk)

Three-year outcomes of A Randomized Multicentre Trial Comparing Revascularization and OMT of CTO (Euro CTO)

Study plan and 3-year outcome of the EuroCTO trial

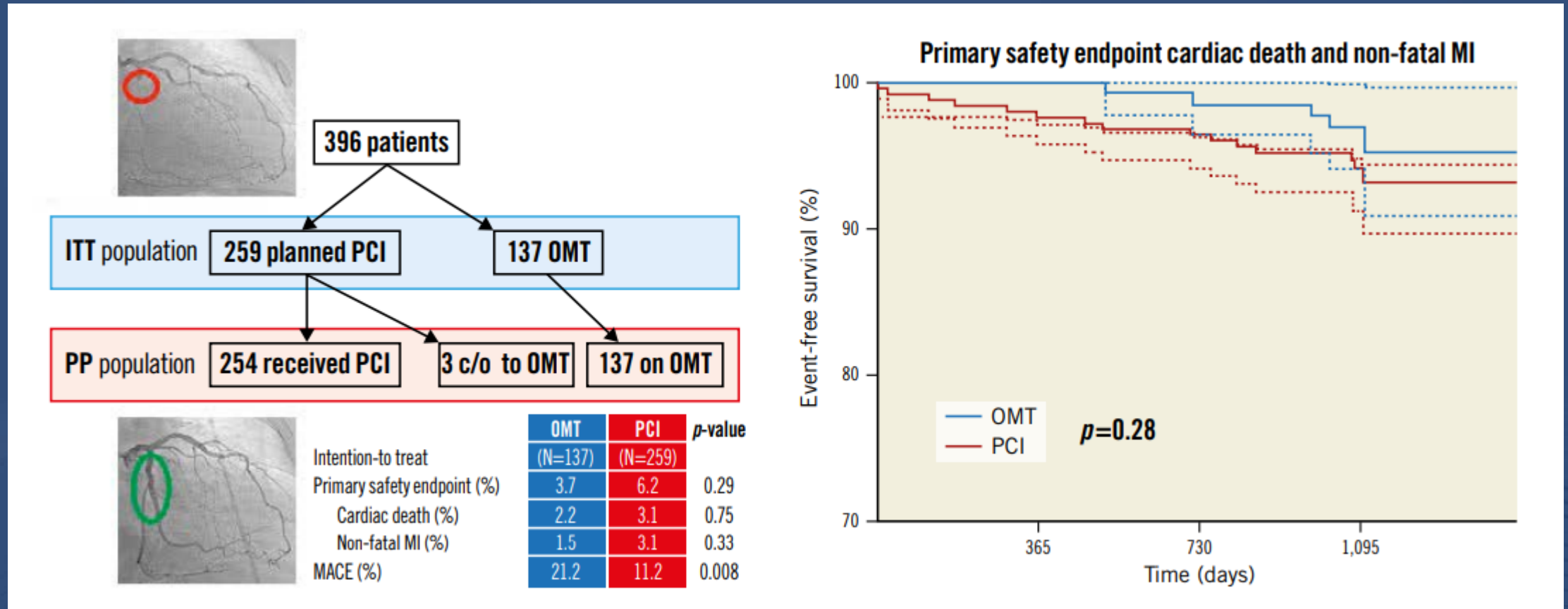

Three-year outcomes of A Randomized Multicentre Trial Comparing Revascularization and OMT of CTO (Euro CTO)

No difference in the rate of cardiovascular death or myocardial infarction between PCI or OMT among patients with a remaining single coronary CTO

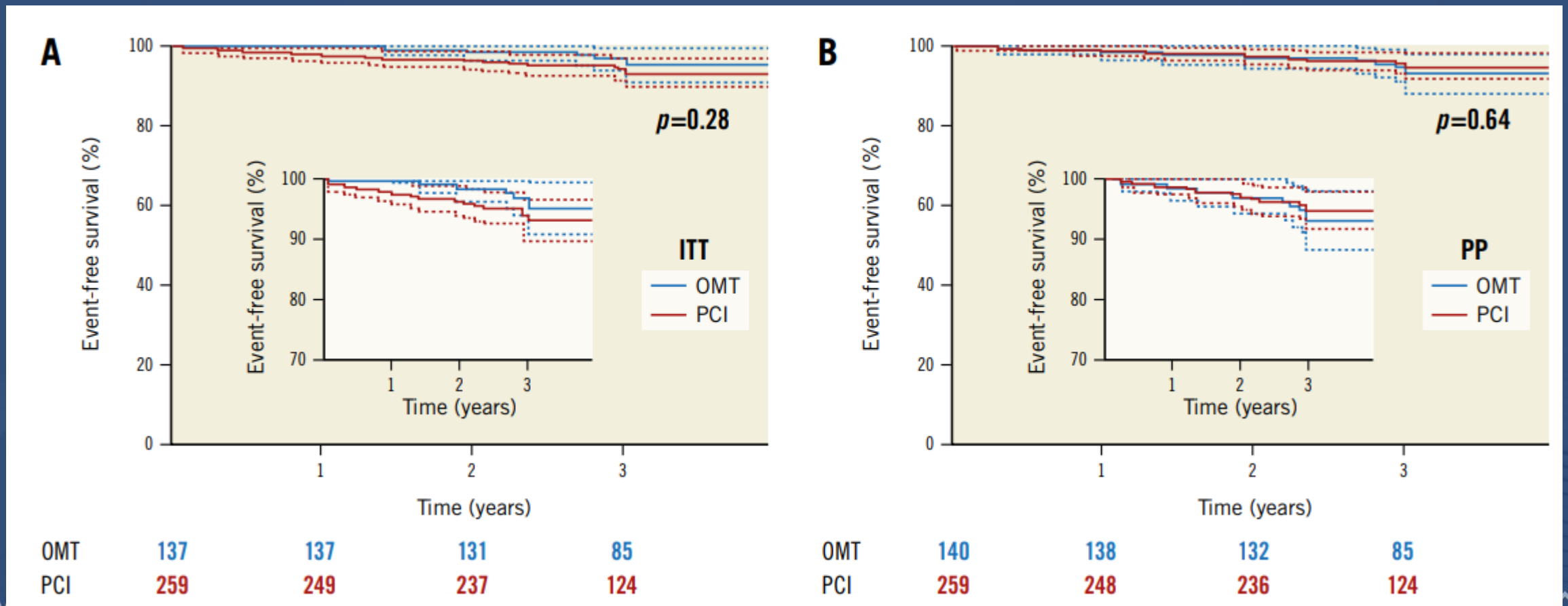

Three-year outcomes of A Randomized Multicentre Trial Comparing Revascularization and OMT of CTO (Euro CTO)

The MACE rate was higher in the OMT group due largely to ischaemia-driven revascularisation.

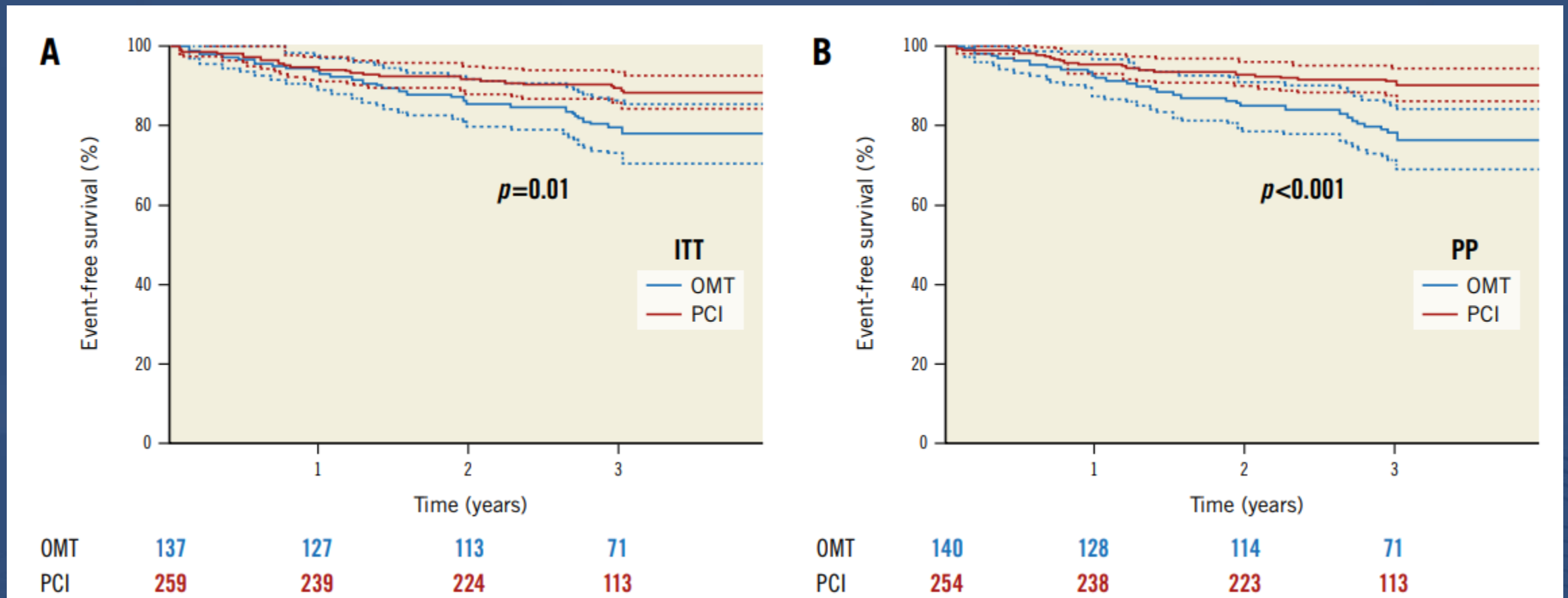

Long term follow-up of patients with CTO previously randomized with OMT or PCI (COMET-CTO)

The primary endpoint – the incidence of MACE defined as cardiac death, MI, and revascularization [PCI or CABG]

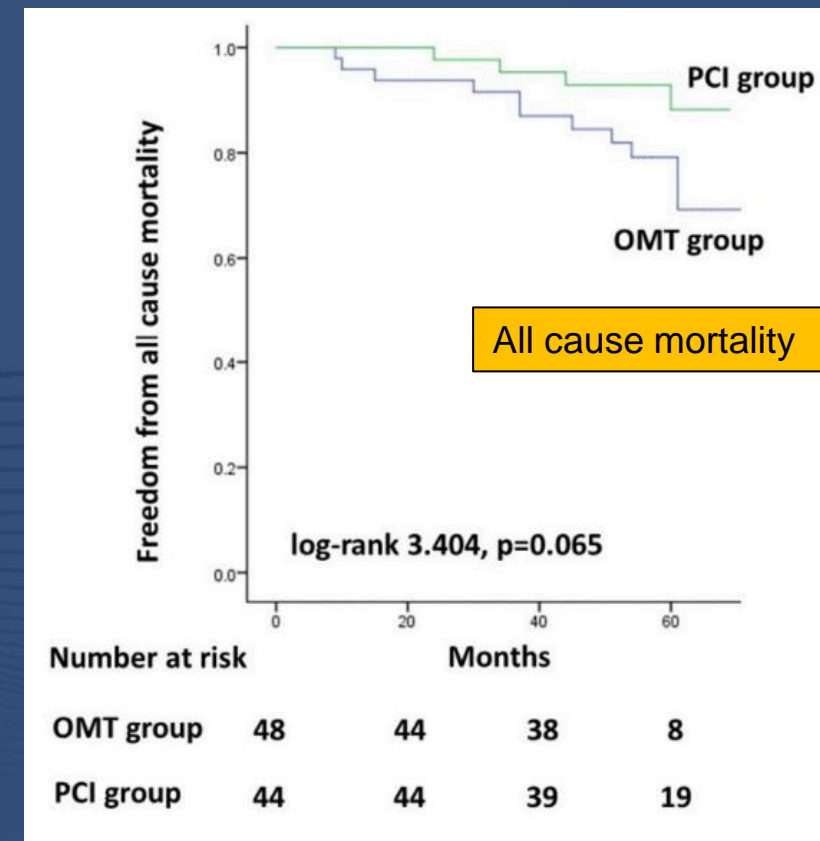
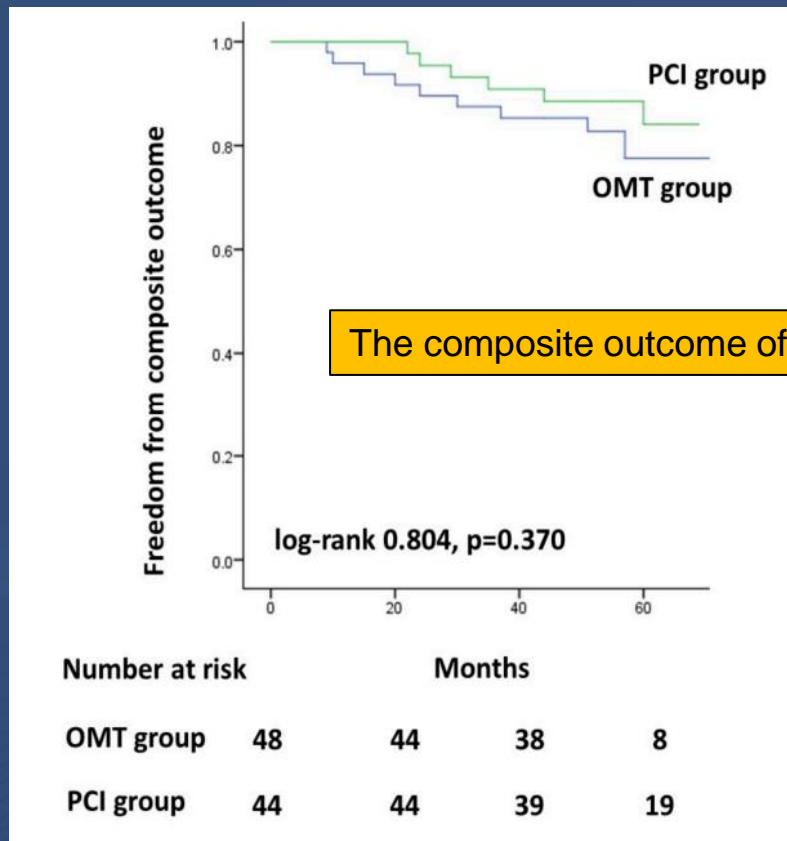

Chronic Total Occlusion : Devices

Guidewires for CTO

Features required for CTO wires

Penetration force for penetrating proximal fibrous cap and advancing into true lumen

Pushability for crossing chronic occlusions and complex lesions with heavy calcifications and tough fibrous tissues

Steerability for easy manipulate in various directions with good torque transmission

Shaping Memory of the tip

Choice of CTO Guidewire



Hydrophobic wire	Hydrophilic wire
Better tactile response Good for older, fibro-calcific lesions Good for initial piercing of fibrous cap	Good for less chronic total occlusion ; softer May find microchannels easier Follow path of least resistance ; easier to go extra-luminal

Hallmarks of a CTO Guidewire

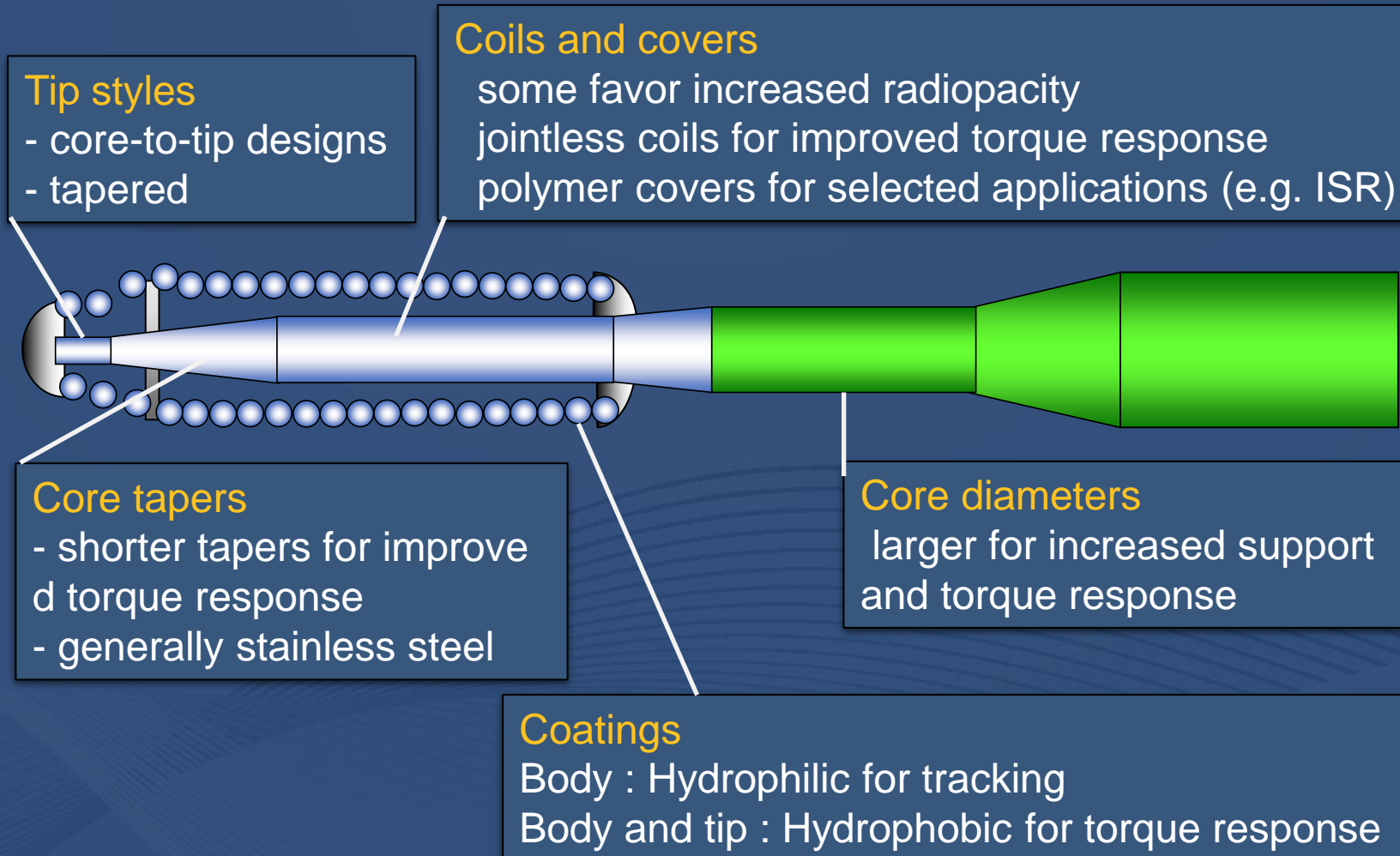

Polymer Jacket Type to Reduce the Resistance

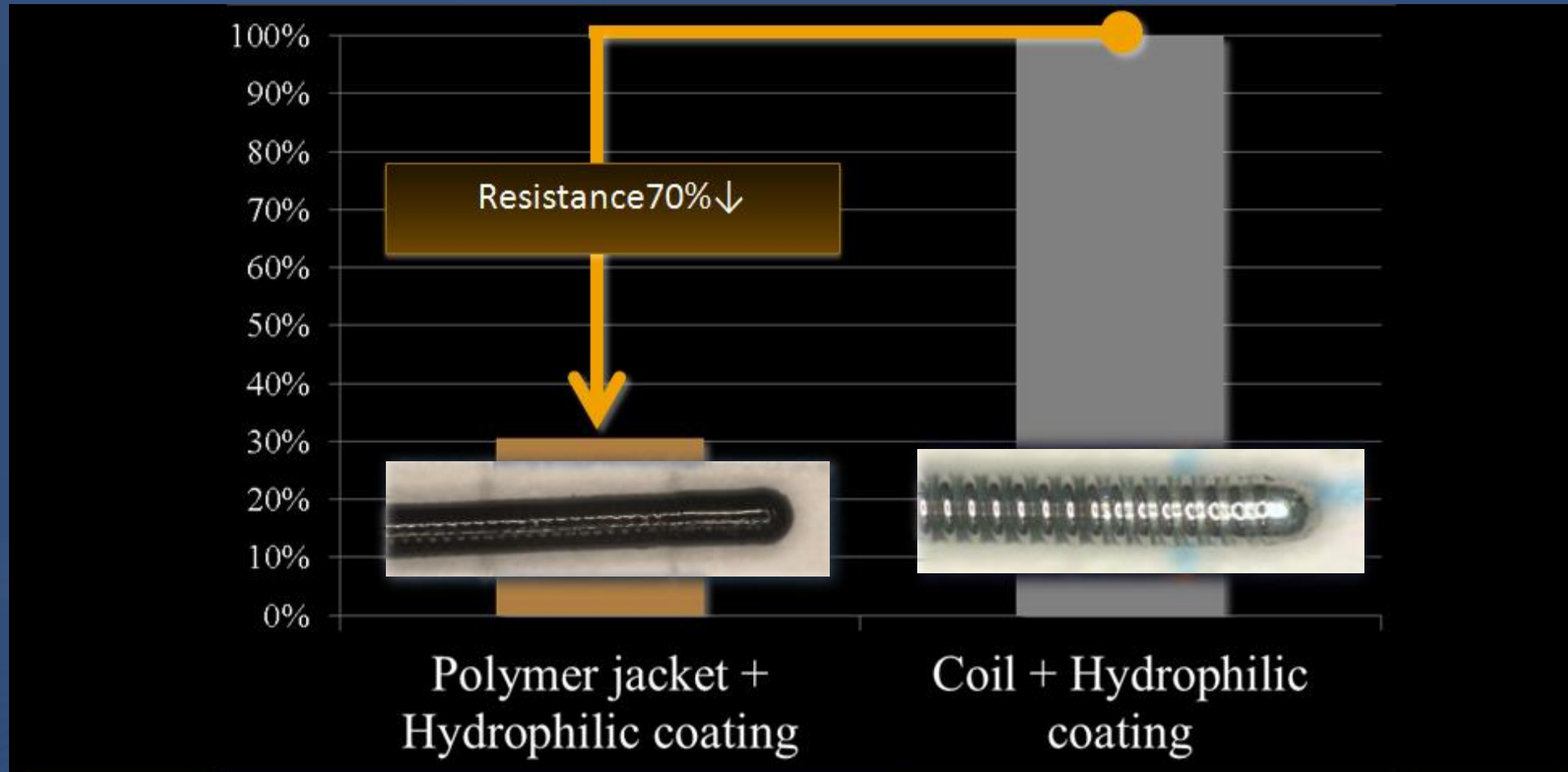

Guidewire Selection

Stiff wires

Miracle 4.5g, 6g (Asahi Intec) for standard step-up strategy

Miracle 3g → Miracle 4.5g

→ Miracle 6g → Miracle 12g or Conquest

Miracle 12g (Asahi Intec) for so tight CTO

to penetrate proximal or distal cap

to crash tight plaque within CTO

to puncture from pseudo to true lumen

Conquest Pro (Asahi Intec) for so tight CTO

to penetrate proximal or distal cap

to penetrate tight plaque within CTO

to puncture from pseudo to true lumen

Guidewire Selection

Miracle 12g is more controllable

to penetrate **proximal cap**

to advance in the tight CTO with bending,

to puncture from pseudo to true lumen

Conquest should be used

only when the appropriate direction can be seen

to penetrate **distal cap**

to puncture from pseudo to true lumen

Conquest should not be used

to seek the true lumen or advance for long distance

Guidewire Selection for CTO

Steps for Success

Become familiar with one or two wire sets

Over-the wire balloon or Transit catheter

Frequent wire changes

Frequent reshaping of wire tip

Stepwise approach

Penetration of proximal cap

Wire passage through the body of the CTO

Penetration of the distal cap

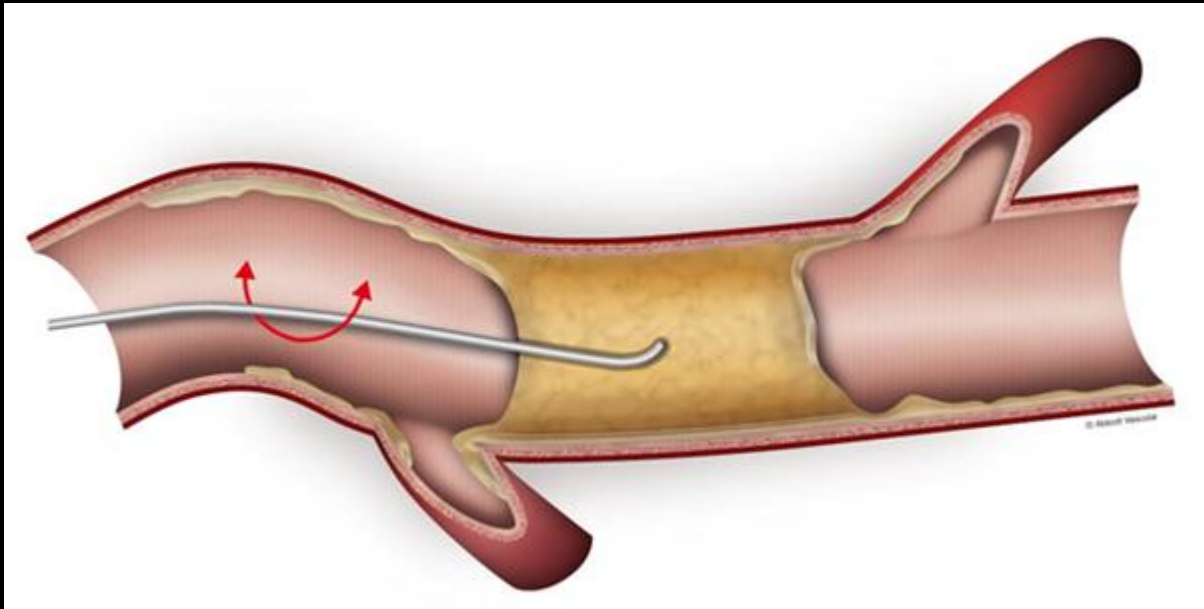

Controlled Drilling



The guide wire is advanced using gentle movements. Straight tip guide wires facilitate tactile feedback and steerability. Step up with stiffer guide wires.

Recommended Guide Wires

Straight Tip Guide Wires

-  ASAHI MIRACLEBROS 3
-  ASAHI MIRACLEBROS 4.5
-  ASAHI MIRACLEBROS 6
-  ASAHI MIRACLEBROS 12

Tapered Tip Guide Wires

-  HT CROSS-IT 100XT
-  HT CROSS-IT 200XT
-  HT CROSS-IT 300XT

Clinical application: Inside *calcified and fibrotic CTO* segment, *ISR*, *Long CTO* segment

Penetration

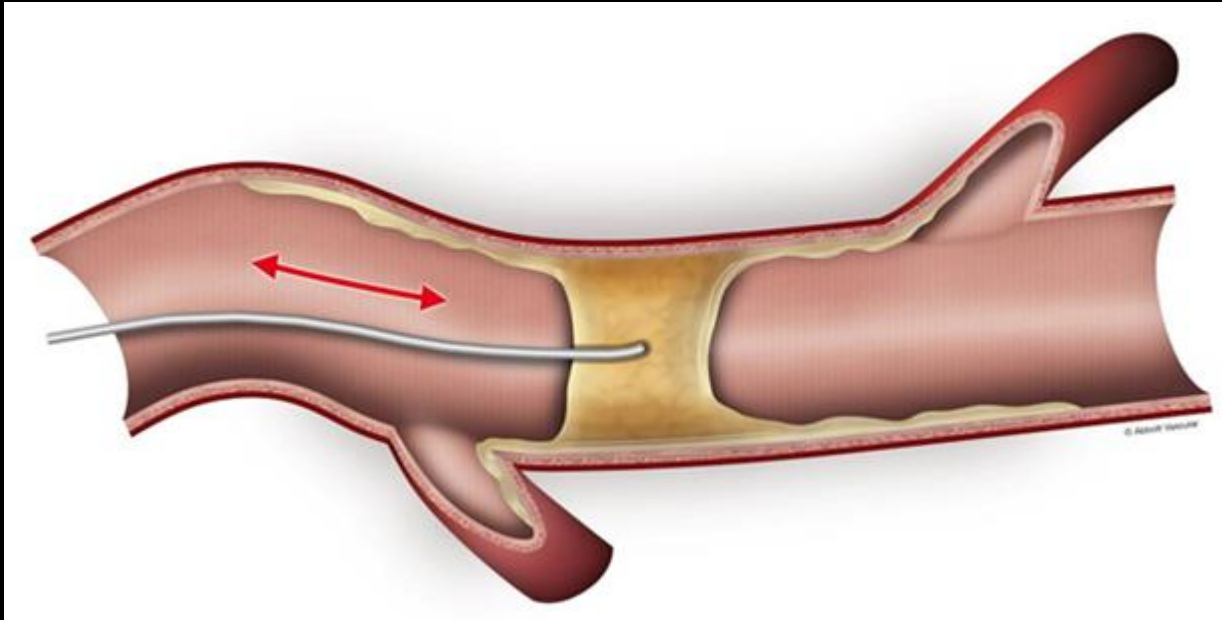

Penetrating the obstruction aiming at the target. The direction of the guide wire is more precisely controlled. Tapered tip guide wires permit higher penetrating forces.

Recommended Guide Wires

Straight Tip Guide Wires

 **ASAHI MIRACLEBROS 12**

Tapered Tip Guide Wires

 **ASAHI CONFIANZA 9**

 **ASAHI CONFIANZA PRO 9**

 **ASAHI CONFIANZA PRO 12**

 **HT CROSS-IT 400XT**

Clinical Application: Penetrate *proximal and distal cap*, *False to true lumen (IVUS)*,
Change wire direction (2nd wire in *parallel wire technique*)

Sliding-Microchannel tracking

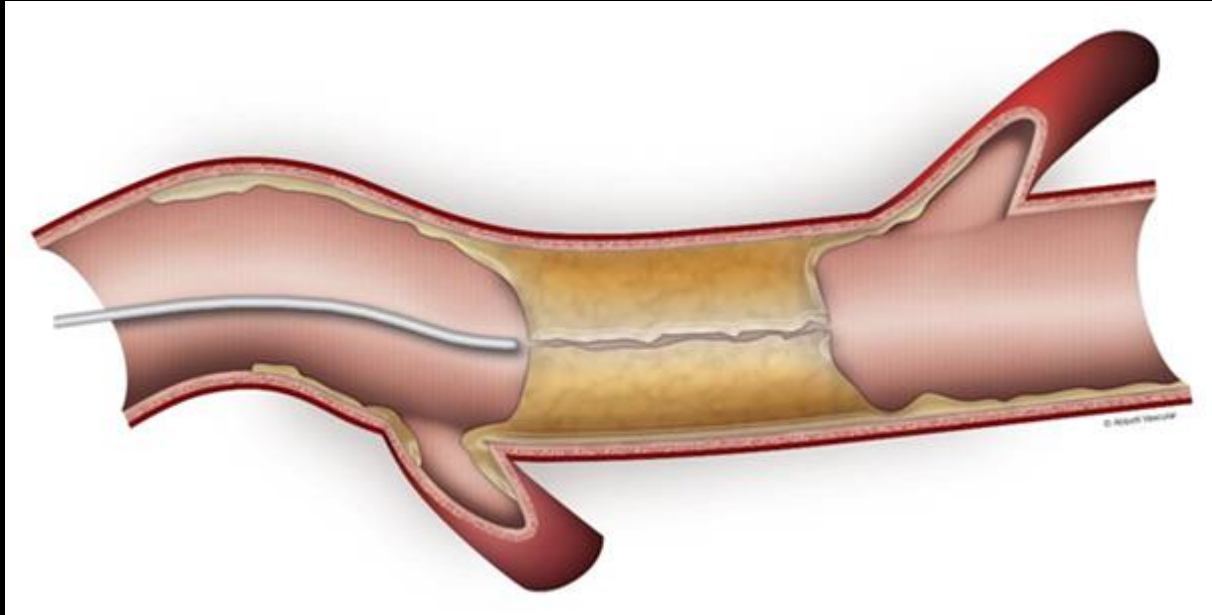

Very lubricious polymer covered guide wires are used to slide through narrow lesions or functional occlusions.

Recommended Guide Wires

Tapered Polymer Tip Guide Wire

 **ASAHI FIELDER XT**

Polymer Covered Guide Wires

 **HT PILOT 150**

 **HT PILOT 200**

Clinical Application: Tracking *micro channels* (visible and invisible)

Collateral tracking

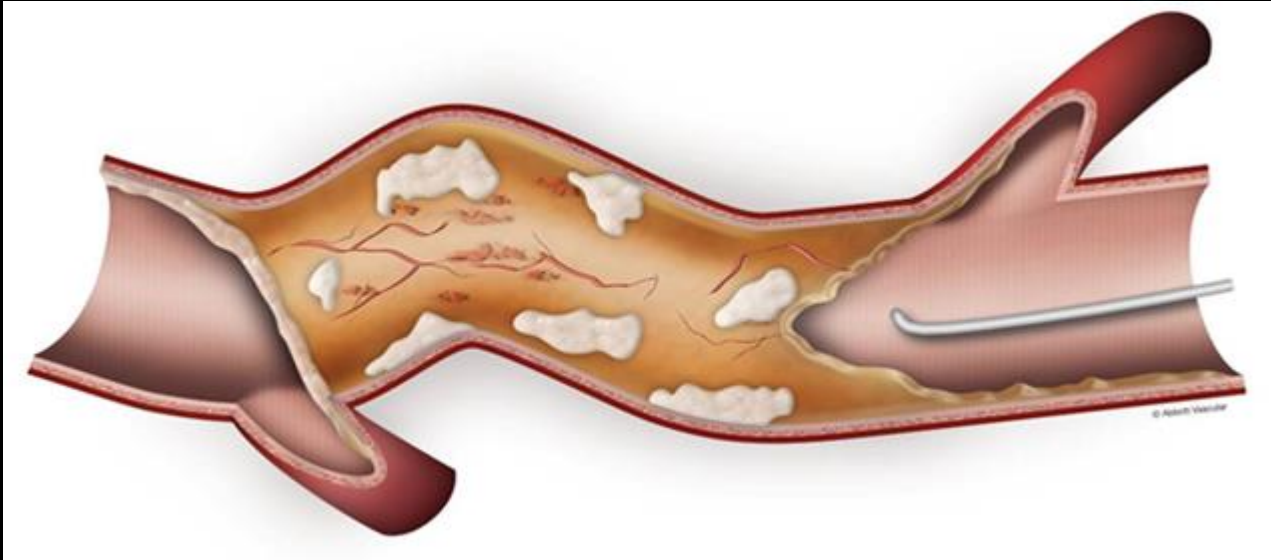

Recommended Guide Wires

Tapered Polymer Tip Guide Wire



ASAHI FIELDER XT

Straight Polymer Tip Guide Wire



ASAHI FIELDER FC



ASAHI FIELDER

When an antegrade approach to the CTO fails or is contraindicated, the CTO can sometimes be approached from the retrograde direction. Flexible polymer covered guide wires are recommended for navigation through septals.

Clinical Application: *Retrograde techniques, CART, Reverse IVUS guided CART*

Chronic Total Occlusion



CONTROLLED DRILL

ULTIMATE bros 3
Miracle 3 / MIRACLE bros 3
Miracle 4.5 / MIRACLE bros 4.5
Miracle 6 / MIRACLE bros 6
Miracle 12 / MIRACLE bros 12
Intermediate / MEDIUM

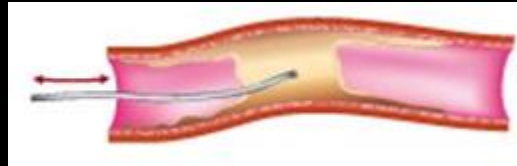

PENETRATION TECHNIQUE

Conquest / CONFIANZA
Conquest Pro / CONFIANZA PRO
Conquest Pro 12 / CONFIANZA
PRO 12
Miracle 12 / MIRACLE bros 12

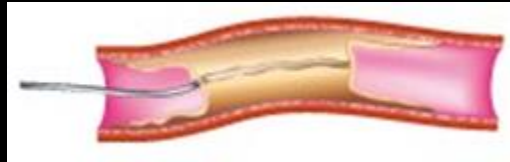

SLIDING TECHNIQUE

Fielder, Fielder FC, Fielder XT



RETROGRADE APPROACH

Fielder, Fielder FC, Fielder XT

Chronic Total Occlusion

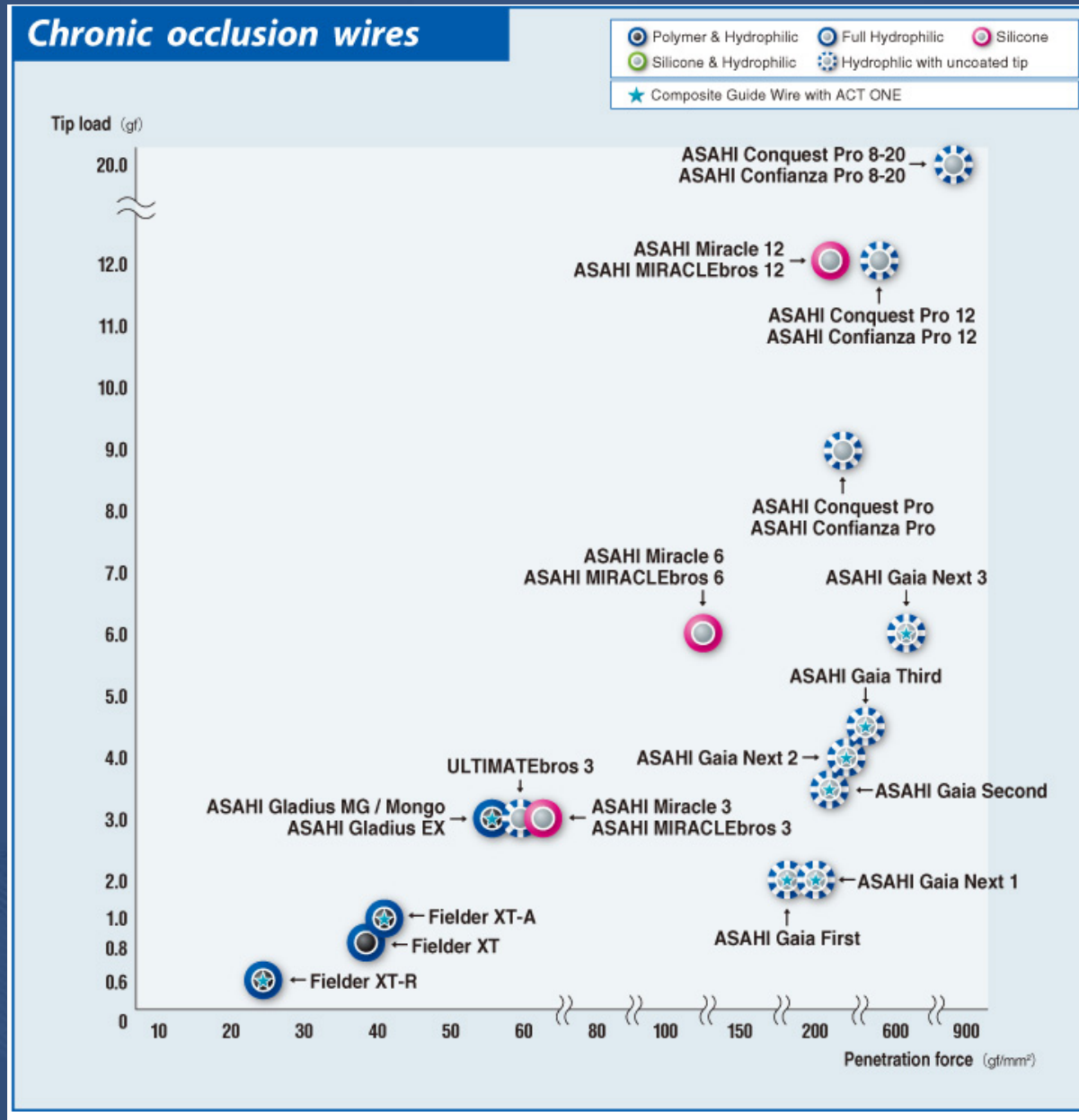

Chronic Total Occlusion

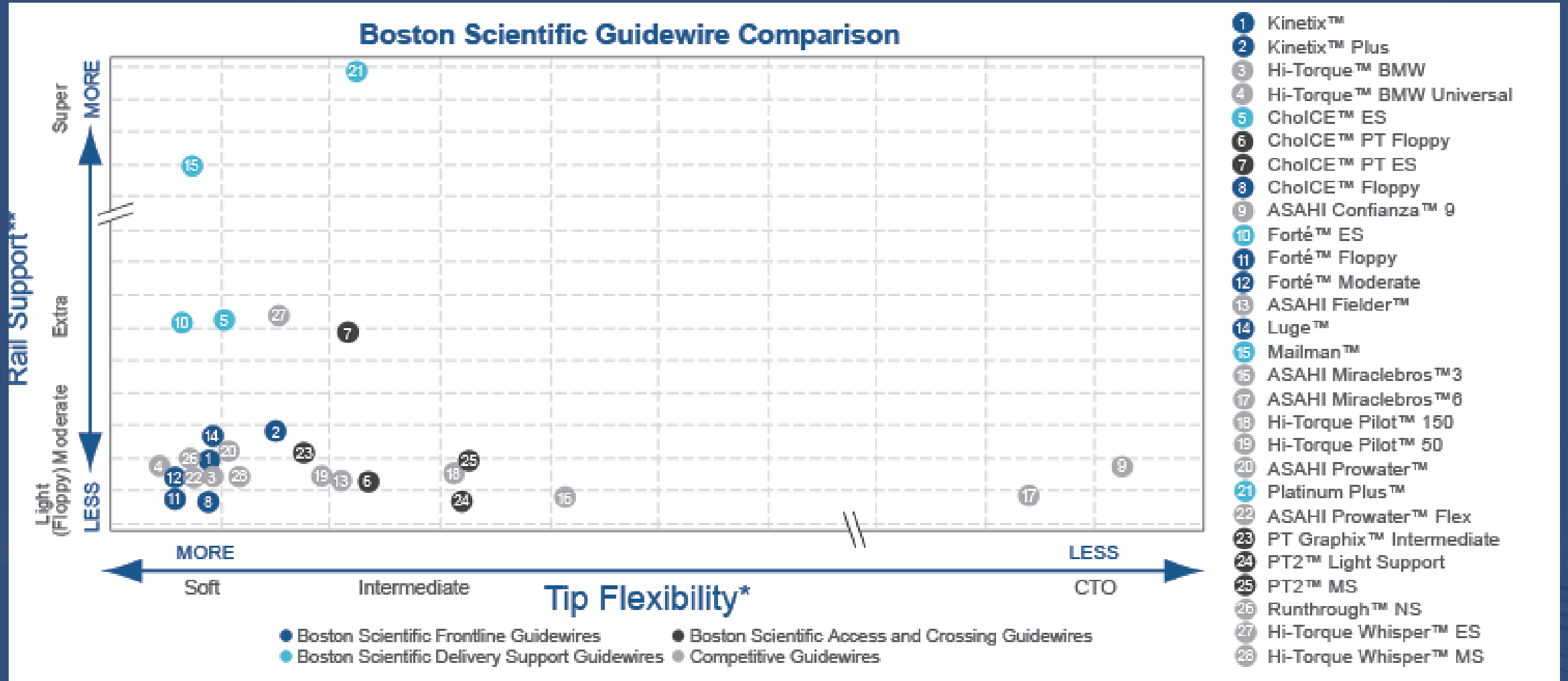

Access wires classified by core design

	Stainless Steel	Nitinol	
Shaping Ribbon 	High Torque F2	BMW Universal-2* Cougar	Abbott Asahi Boston Sci Medtronic Terumo
Core-to-tip 	Pro-Water Marvel Advance	Run-Through BMW Elite	
Compound tip 	Sion Blue Samurai		

Approach to antegrade true-to-true wiring contemporary wire modulation

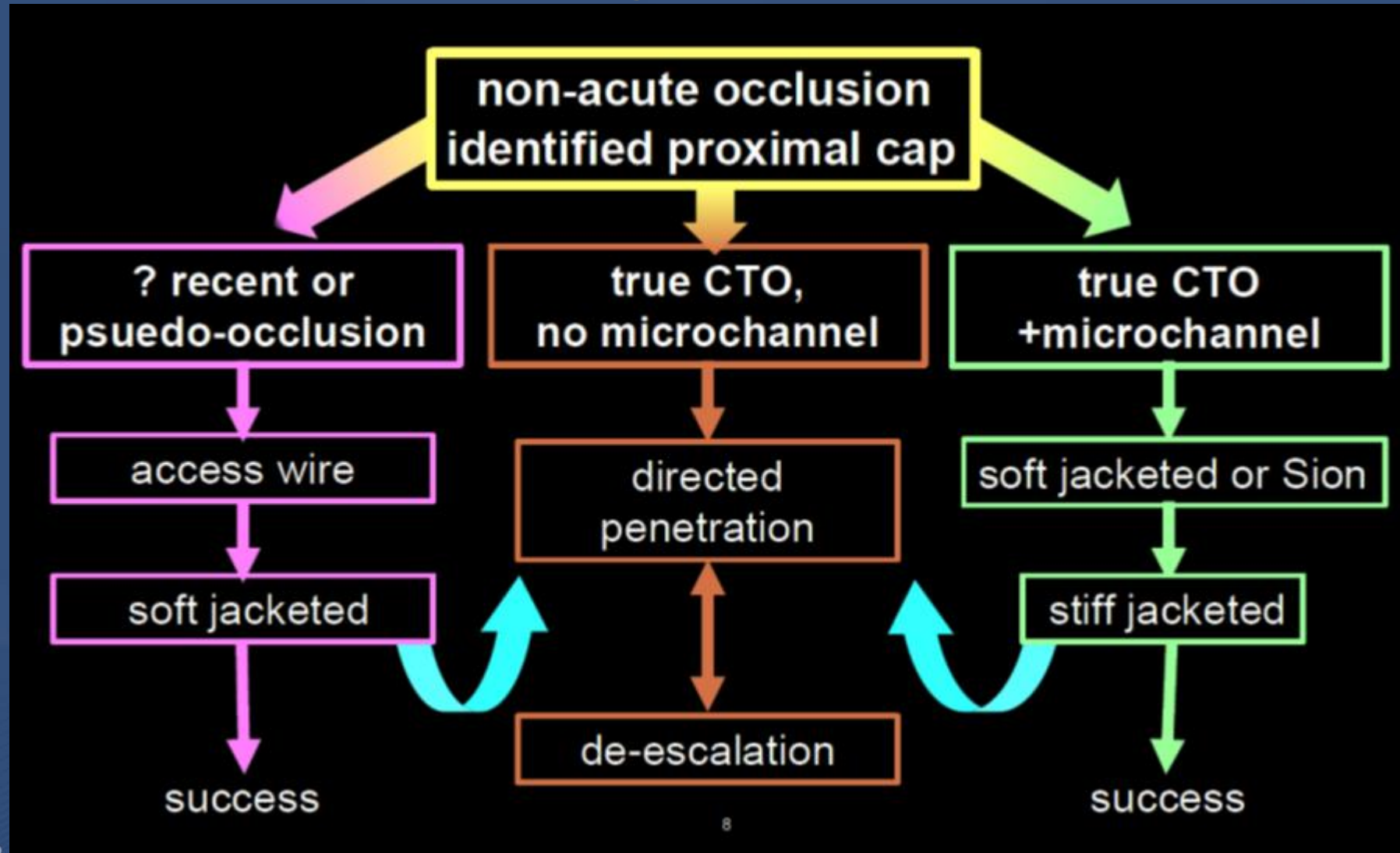

Directed Penetration wires

- progressive tip load, progressive torsional rigidity

Conventional 0.014
Hi-Torque Standard
Miracle Bros
Halberd

Tapered tip coil
Confianza
Cross-It XT
Hornet (0.008")

Stiff Jacketed
Pilot 200
Gladius

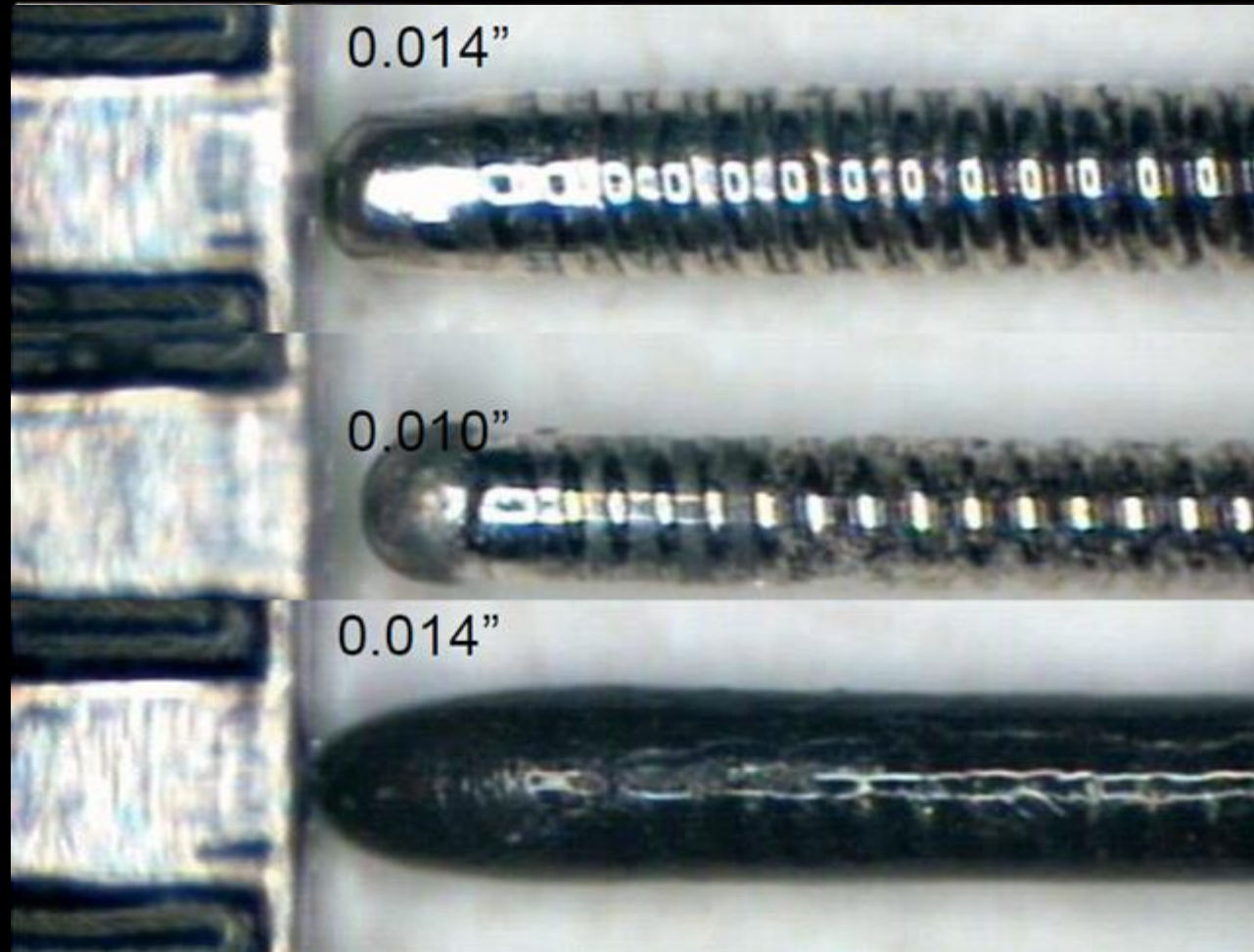

2nd/3rd Gen Directed Penetration wires

Progress 40 / 80 / 120

Progress 200T

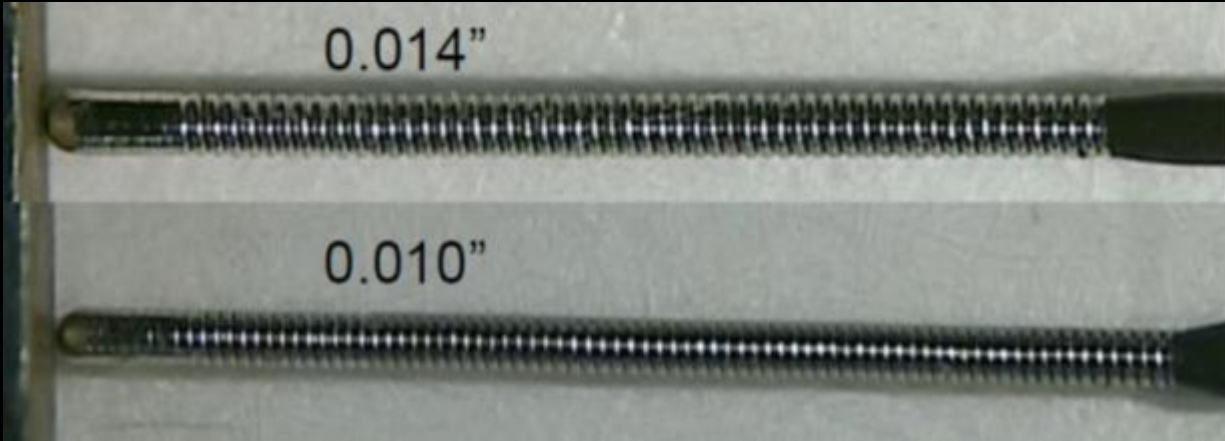

Gaia	Tip Type	Diam	Load
Gaia 1st	Coil-in-coil	0.010	1.7 gm
Gaia 2nd	Coil-in-coil	0.011	3.5 gm
Gaia 3rd	Coil-in-coil	0.012	4.5 gm

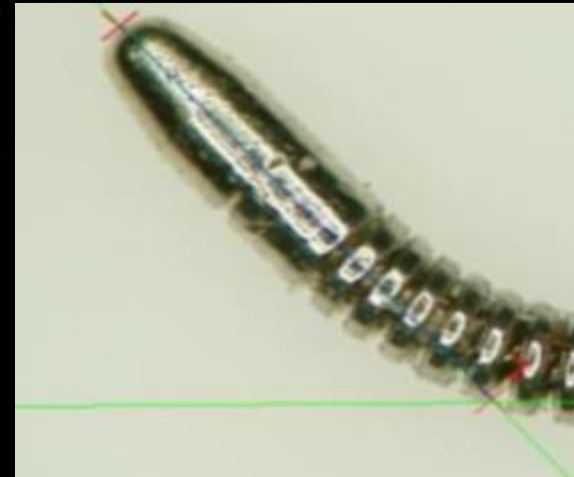

Collateral Crossing wires

- low tip load, atraumatic tip shape, lubricity

<i>Fielder FC</i>	0.014"	0.8gm
<i>Pilot 50</i>	0.014"	1.0gm
<i>Fielder XT-A</i>	0.009"	1.0gm



Sion 0.8gm

Sion Black 0.8gm

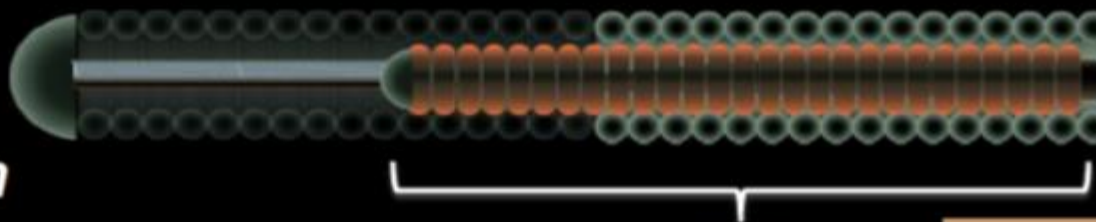

0.014" multi-element composite core

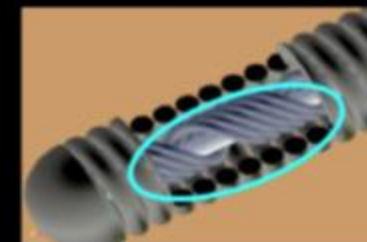
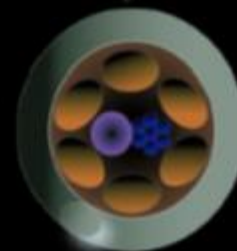

Big Tips Are for Waiters!

0.010"
tip



0.007"
microchannel

0.014"
tip



0.007"
microchannel

ASAHI Neo's Fielder

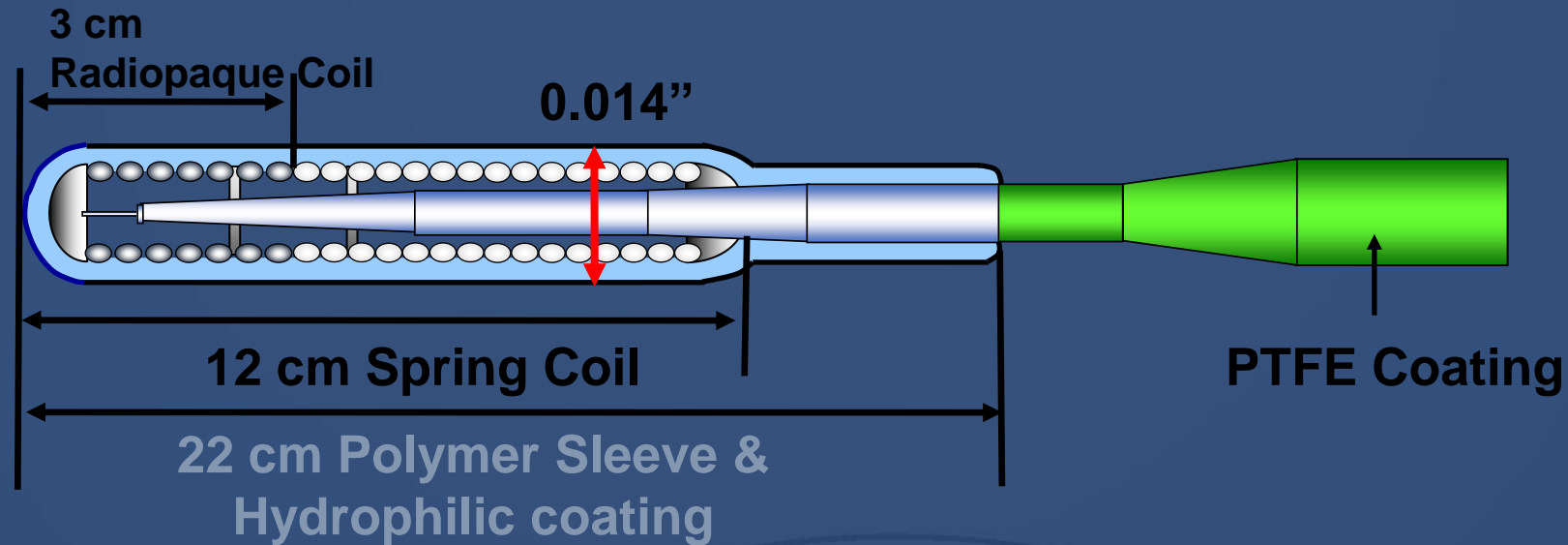

Catalog No.	AGP140000
Tip weight	1.0 g
Radiopacity length	3 cm
Outside diameter	0.014 inch
Total length	175 cm

ASAHI FIELDER FC PTCA Guide

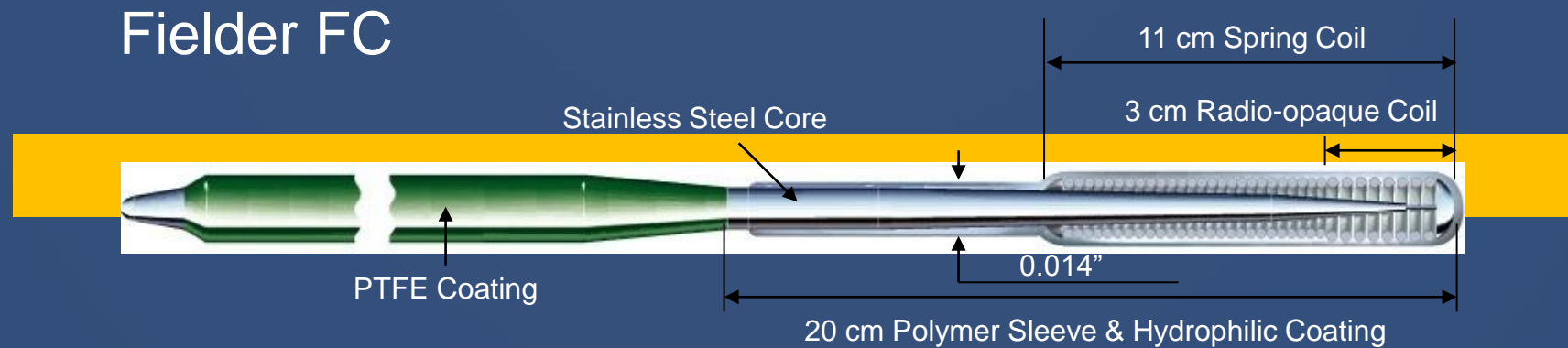

Device description

: Polymer covered guide wire with extra support for effortless movement in tortuous anatomy

Stiffness

: Tip Load = 0.8 g

Fielder XT wire

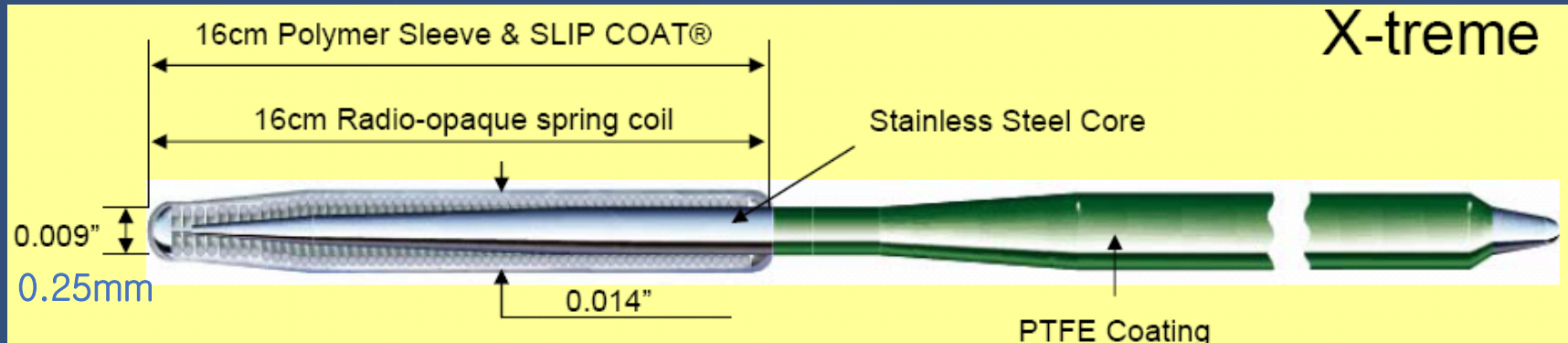

One-Piece Core Wire

: Supports the entire guidewire from the proximal to the distal end. This design transmits the guidewire torque fully from one end to the other.

Tapered Tip

: 0.009" (0.25mm) tapered tip facilitates trackability in tortuous vessels such as fine septal channels with corkscrew aspect.

Flat Core Tip

: Provides flexibility and excellent shaping memory.

Smooth Tapered Core

: Enhances support performance which provides excellent guidewire trackability.

Fielder XT wire

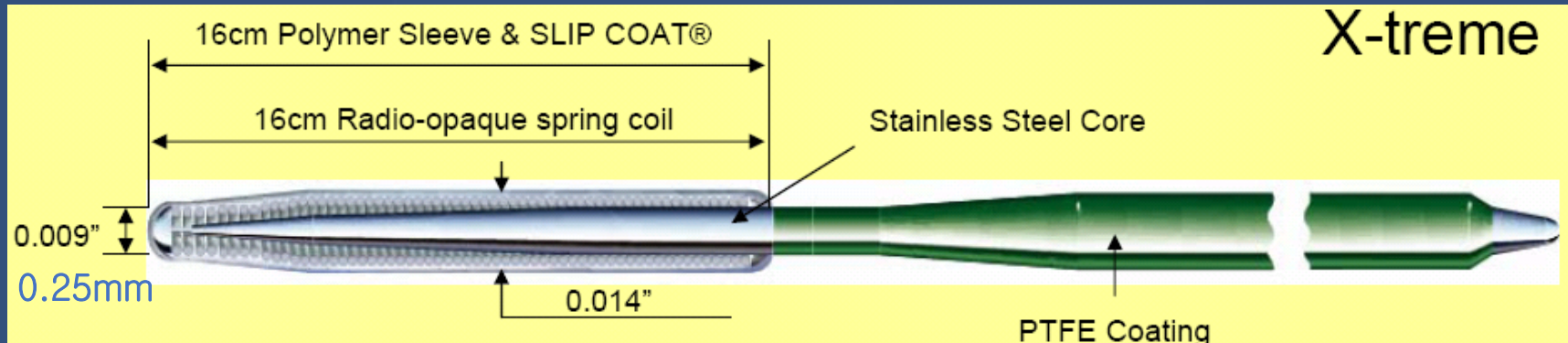

One-Piece Core Wire

: Supports the entire guidewire from the proximal to the distal end. This design transmits the guidewire torque fully from one end to the other.

Tapered Tip

: 0.009" (0.25mm) tapered tip facilitates trackability in tortuous vessels such as fine septal channels with corkscrew aspect.

Flat Core Tip

: Provides flexibility and excellent shaping memory.

Smooth Tapered Core

: Enhances support performance which provides excellent guidewire trackability.

The ASAHI FIEDLER™ FC & XT

- ASAHI FIEDLER™ FC maintains a softer tip, more intermediate support*



- ASAHI FIEDLER™ XT maintains a softer tip,

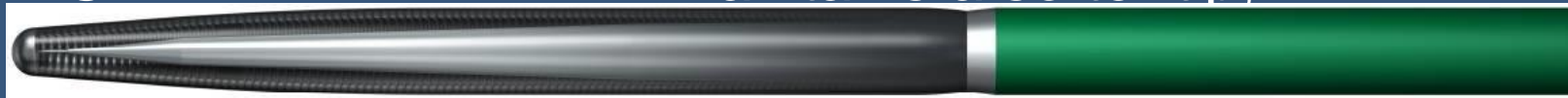

The ASAHI FIEDLER™ FC & XT

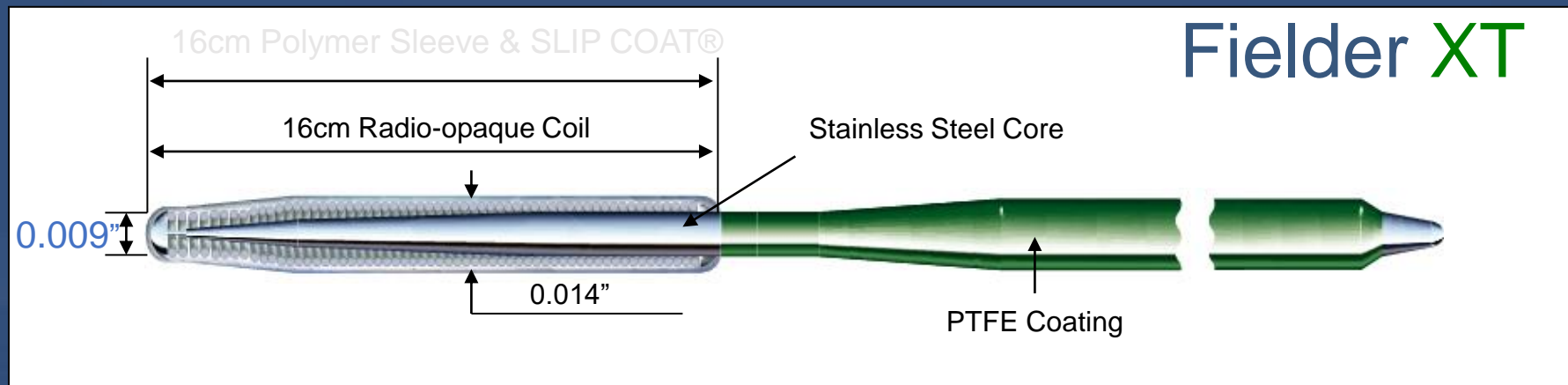
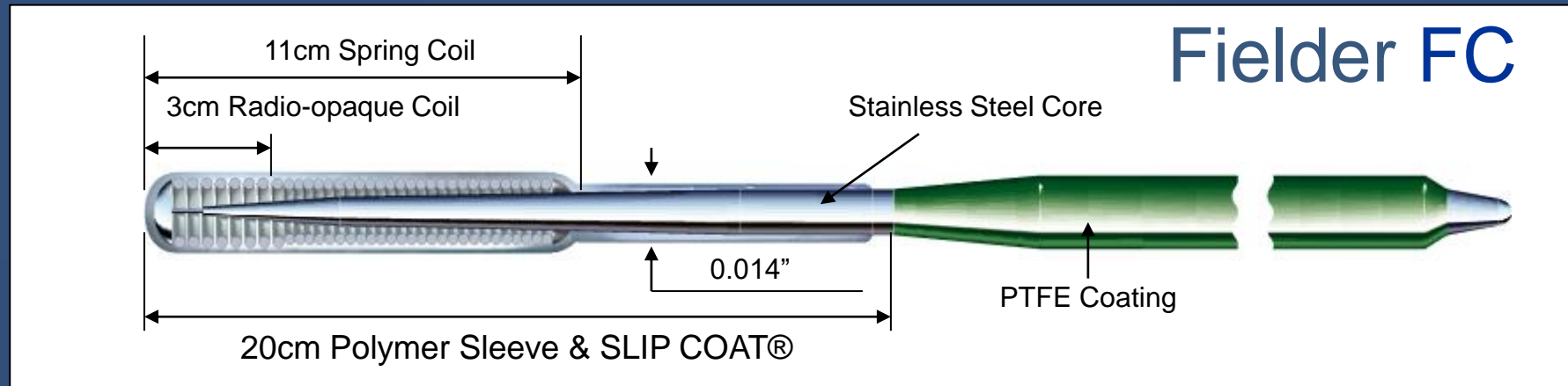

Beyond Fielder XT

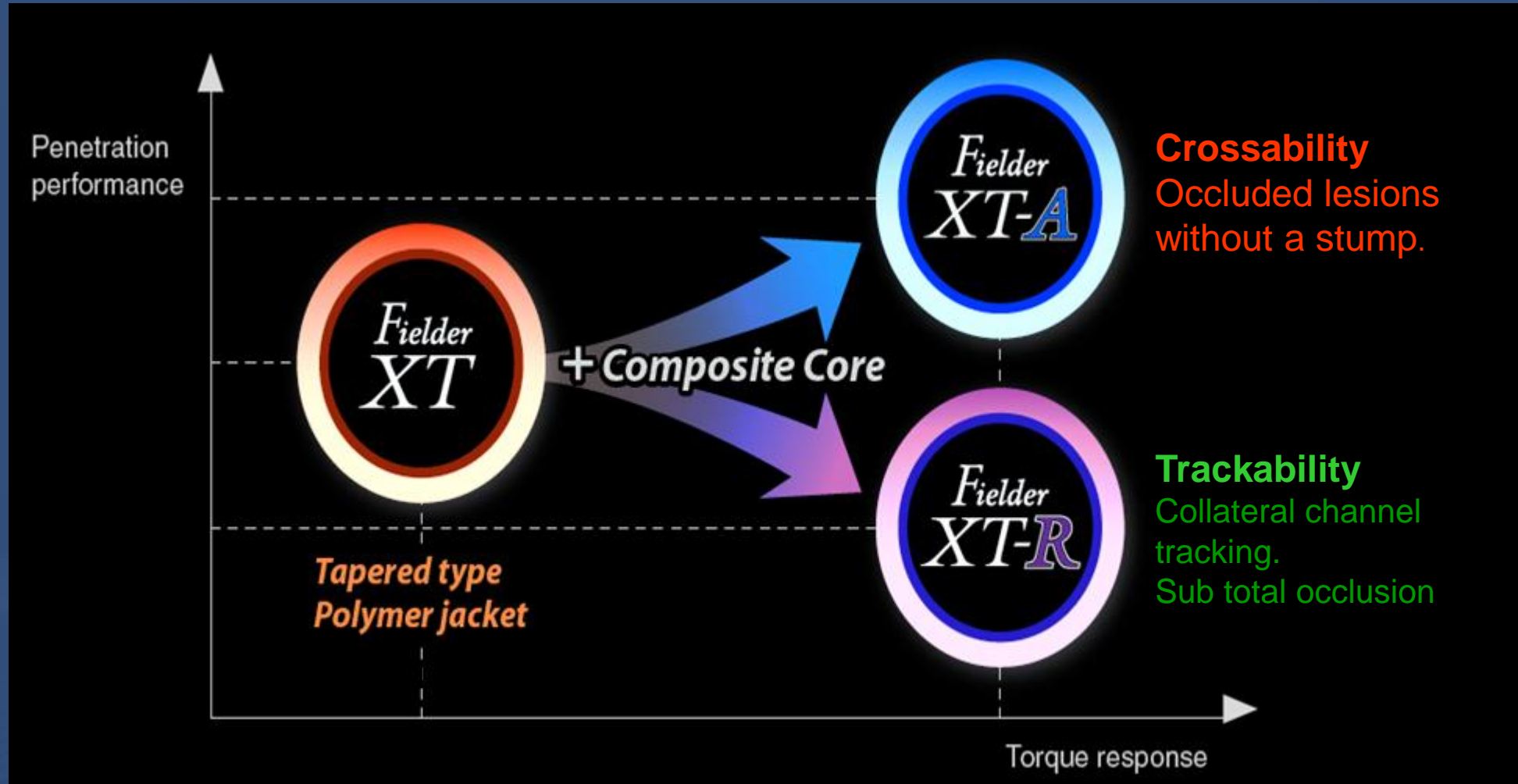

Fielder XT-A & Fielder XT-R

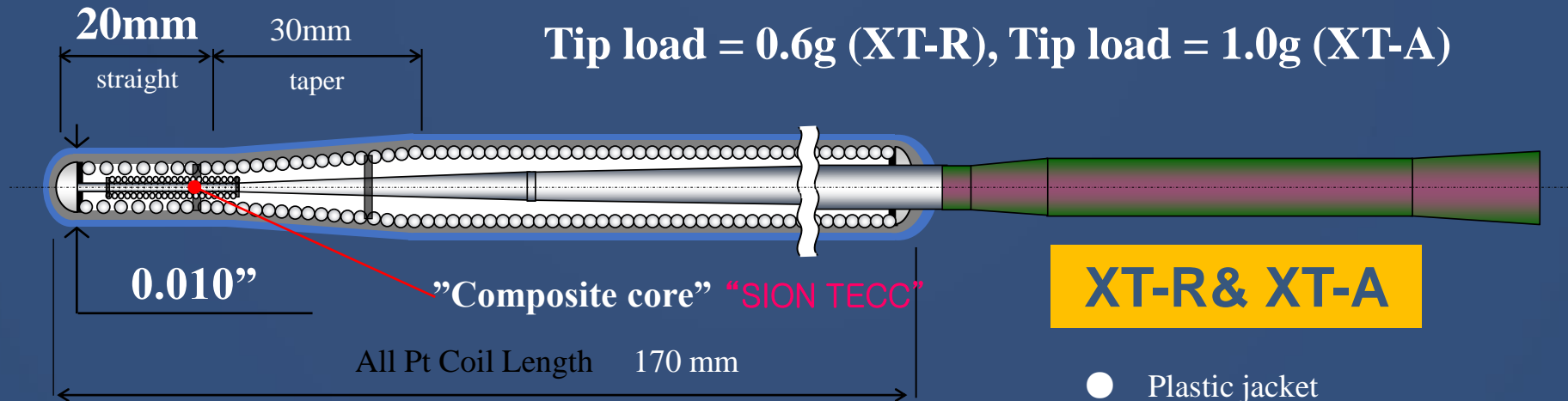

XT-R & XT-A

- Plastic jacket
- Hydrophilic polymer coating
- PTFE coating

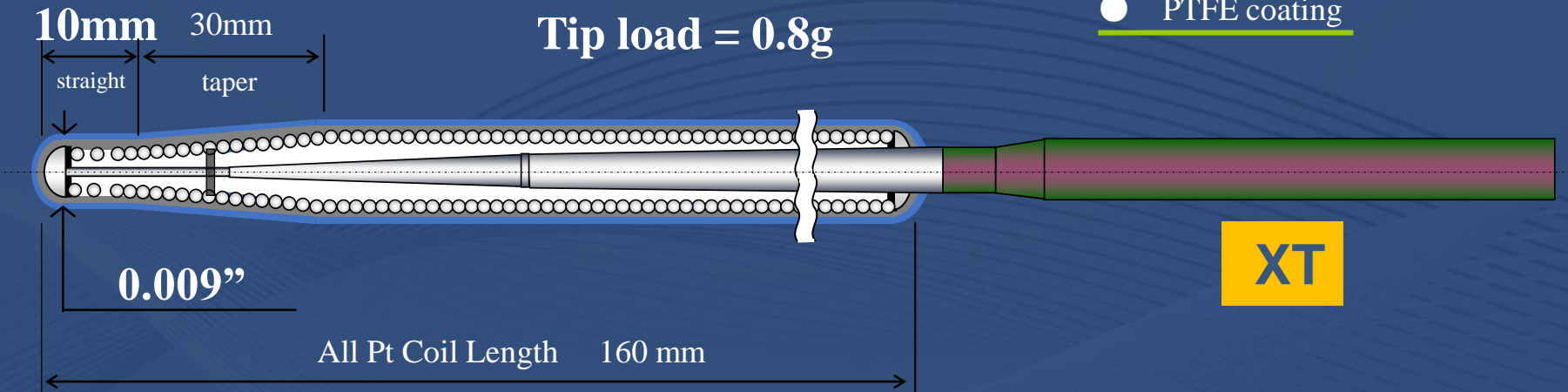

XT

Fielder XR Series: Performance comparison

Torque Whip

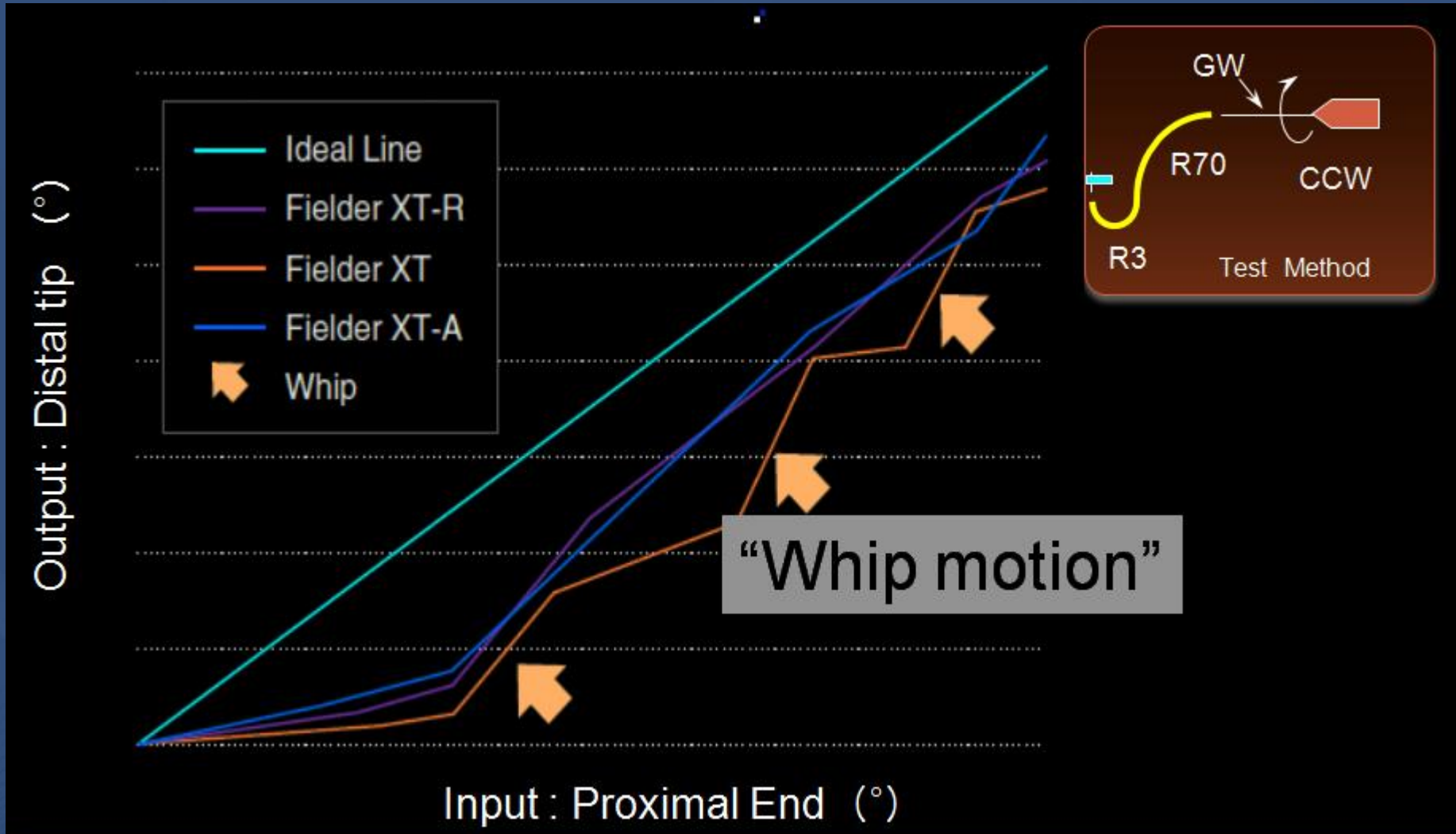

Fielder XR Series: Performance comparison

Torque Force

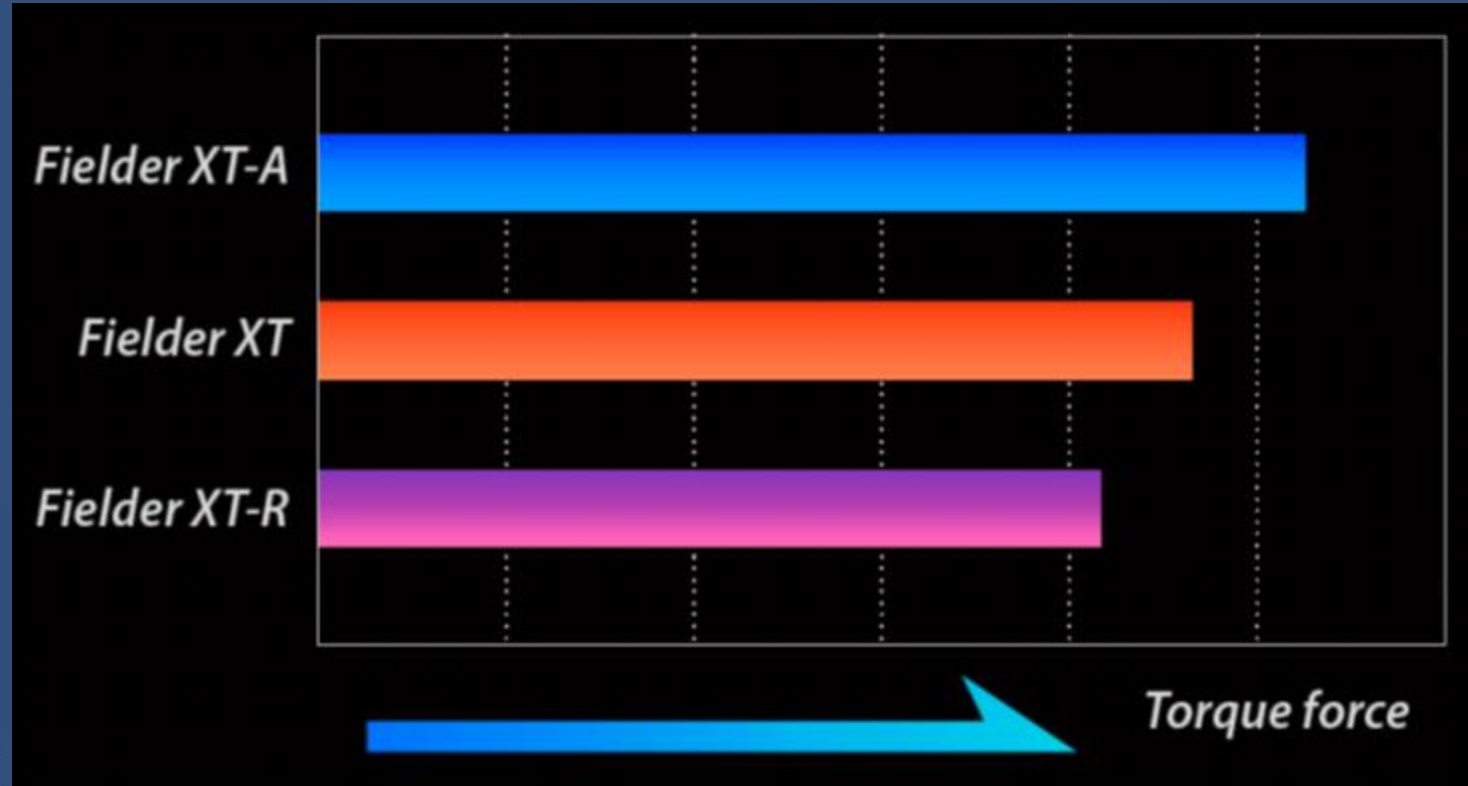

Fielder XT-A has better performance to cross the occluded lesion.

Fielder XR Series: Performance comparison

Tip Flexibility

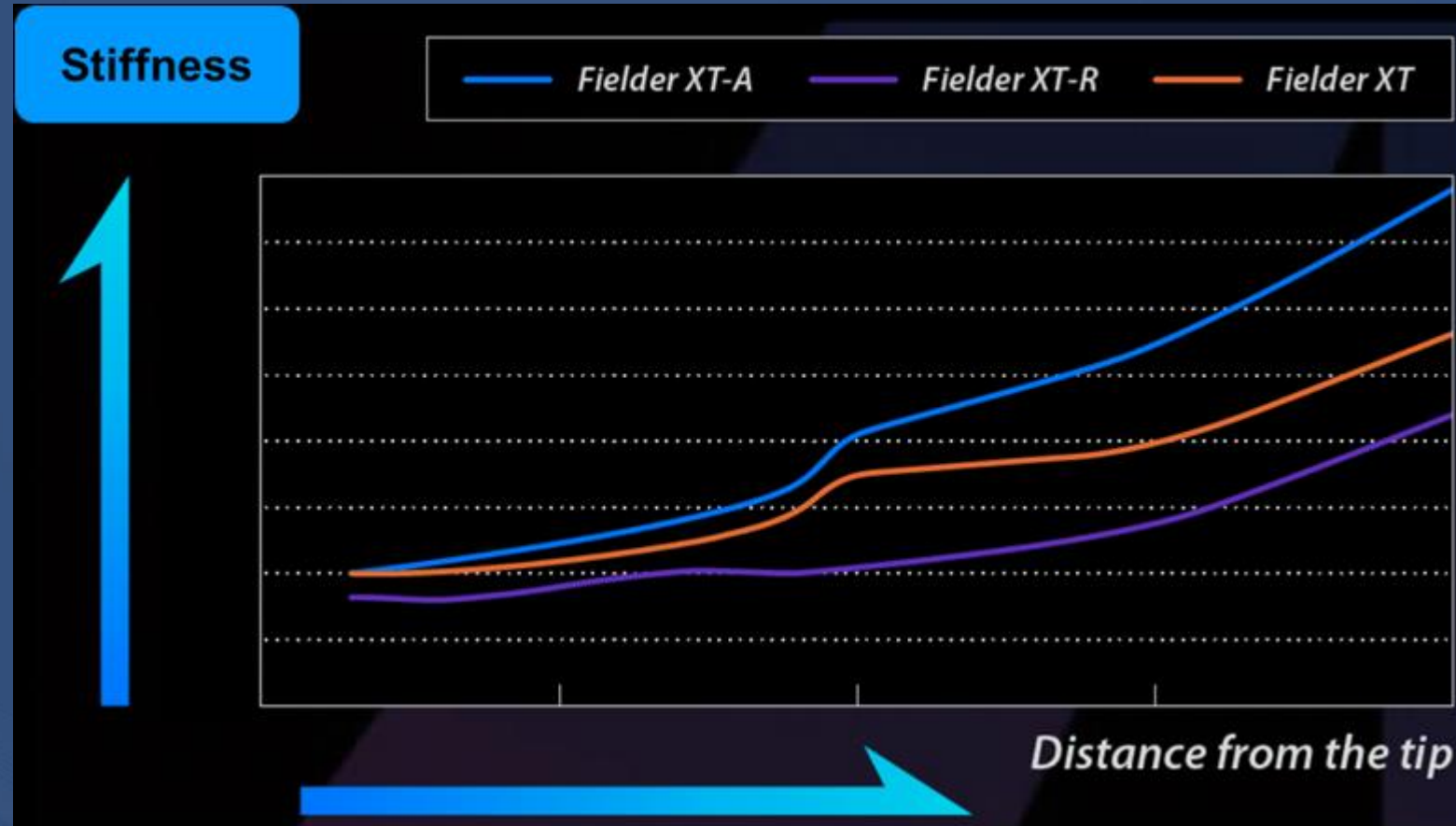

Fielder XT-R has better performance for the channel tracking.

ASAHI Wires:

Miraclebros & Confianza

Miraclebros 3g

Miraclebros 4.5g

Miraclebros 6g

Miraclebros 12g

Confianza 9g

CP(Confianza Pro) 9g

CP(Confianza Pro) 12g

- Excellent trackability, 1:1 torque, and tactile response
- Incremental tip stiffness and wire support (Miraclebros line)
- Smallest tapered tip design (Confianza & CP, 0.009")

Miracle Series

Miracle 3

AG14M050
Tip Radiopacigy
11cm
0.014inch
175cm

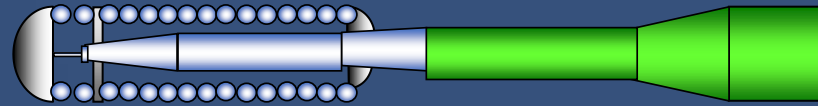

(Tip Stiffness 3.0G)

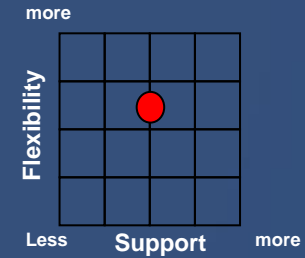

Miracle 4.5

AG14M045
Tip Radiopacigy
11cm
0.014inch
175cm

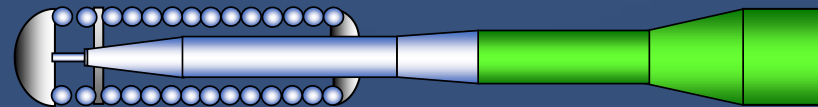

(Tip Stiffness 4.5G)

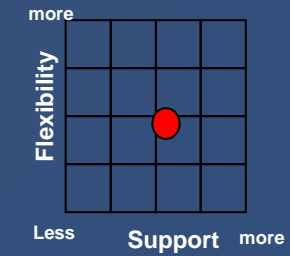

Miracle 6

AG14M060
Tip Radiopacigy
11cm
0.014inch
175cm

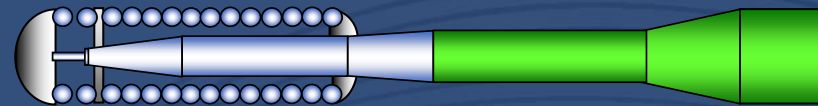

(Tip Stiffness 6.0G)

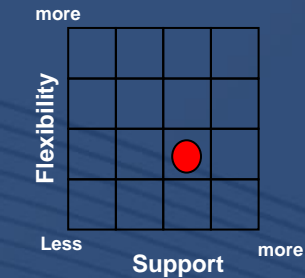

Miracle 12

AG14M070
Tip Radiopacigy
11cm
0.014inch
175cm

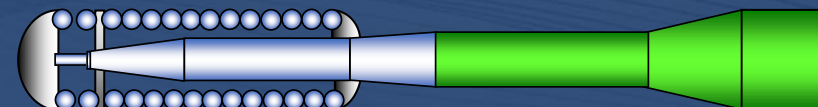

(Tip Stiffness 12.0G)

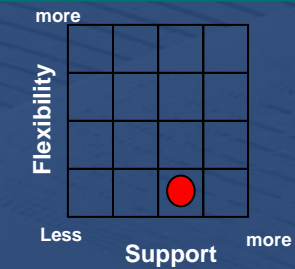

ASAHI ULTIMATE bro3

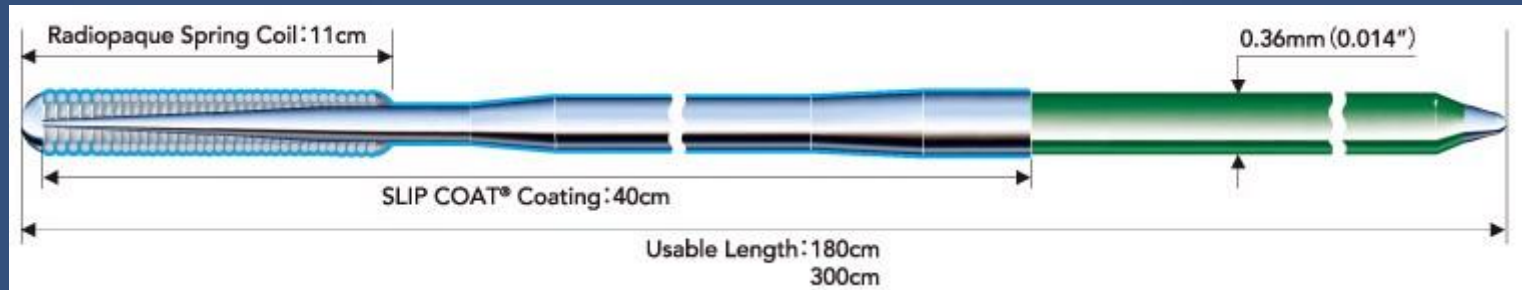

- Long hydrophilic coating maintains high maneuverability, allowing improved wire manipulation in heavy stenosed lesions.
- Fine shaping improves vessel selectivity and reduces the risk of false lumen expansion.

Miracle-Ultimate Series

Miracle bros 0.014inch



Stainless Steel Core Wire

PTFE Coating

Hydrophilic coating

Ultimate bros

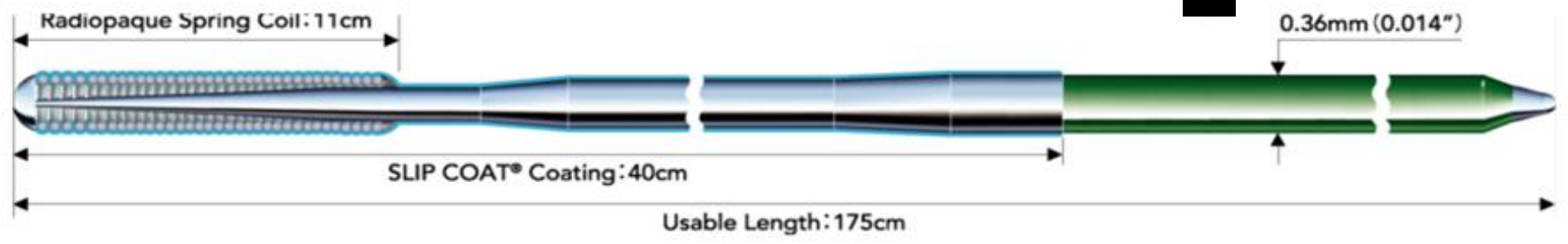

Penetrate with greater tip stiffness

ASAHI SION Family

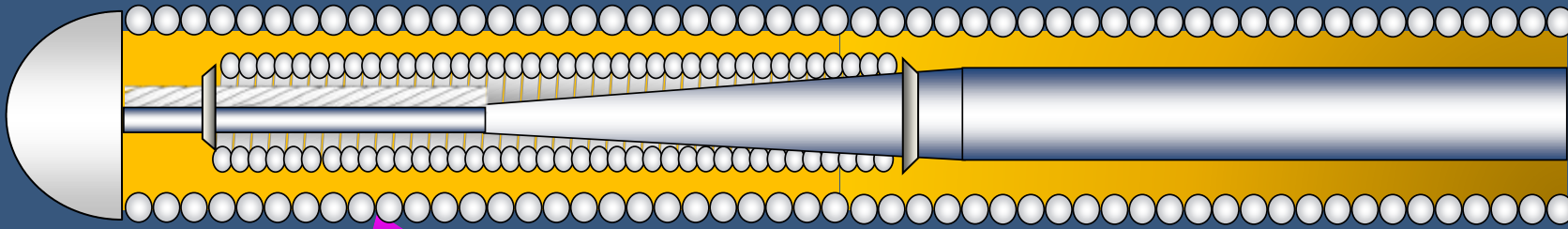

Ropecoil

For torque response & tip durability

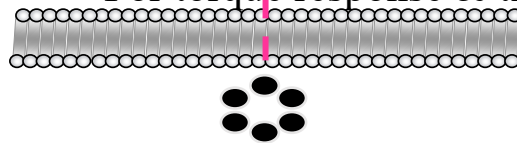

- Unique GW structure ; Double-coil structure
- 0.014” Coil type workhorse GW
- Good torque response - “No whip” motion
- Tip Durability
- Full Hydrophilic coating
- Tip Load 0.7g

ASAHI SION Family

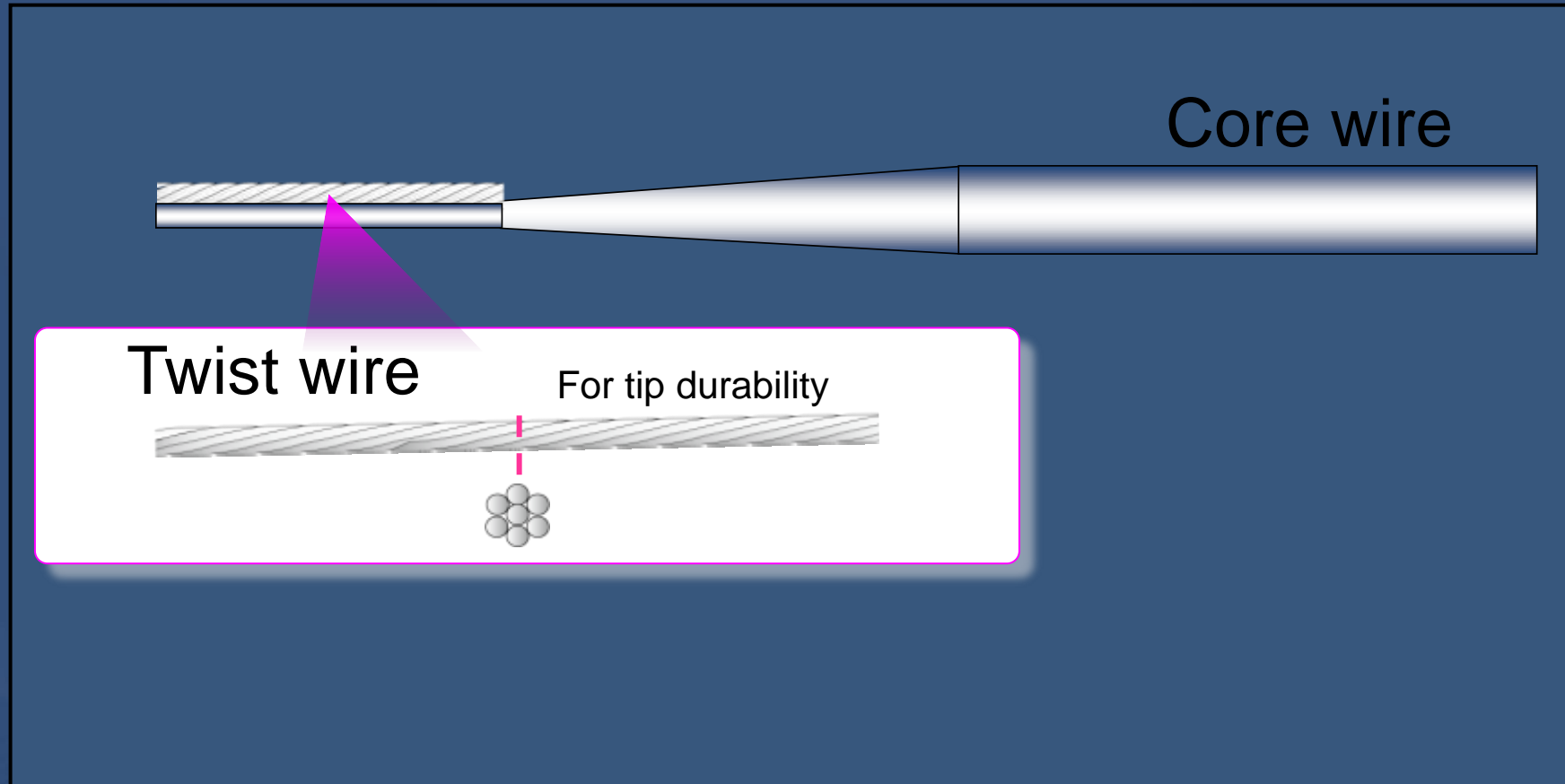

Composite Core of SION Family

Double coil structure

- *Smooth tracking of side branch vessel*
: No-whip motion
- *Retention of maneuverability after crossing severe tortuosity*
: Enhanced tip durability and shape retention

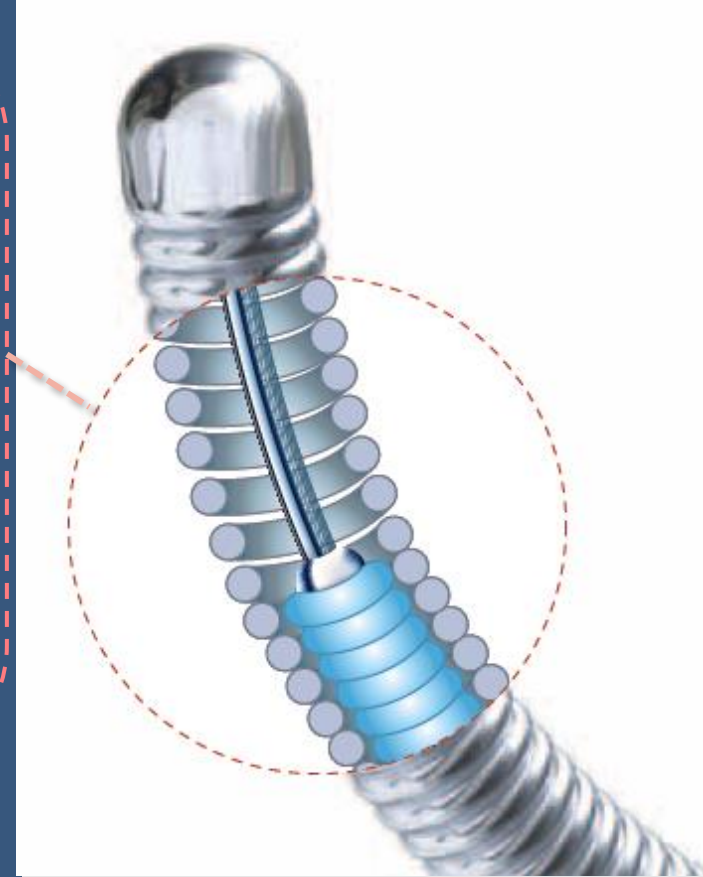

Difference in Torque Whip

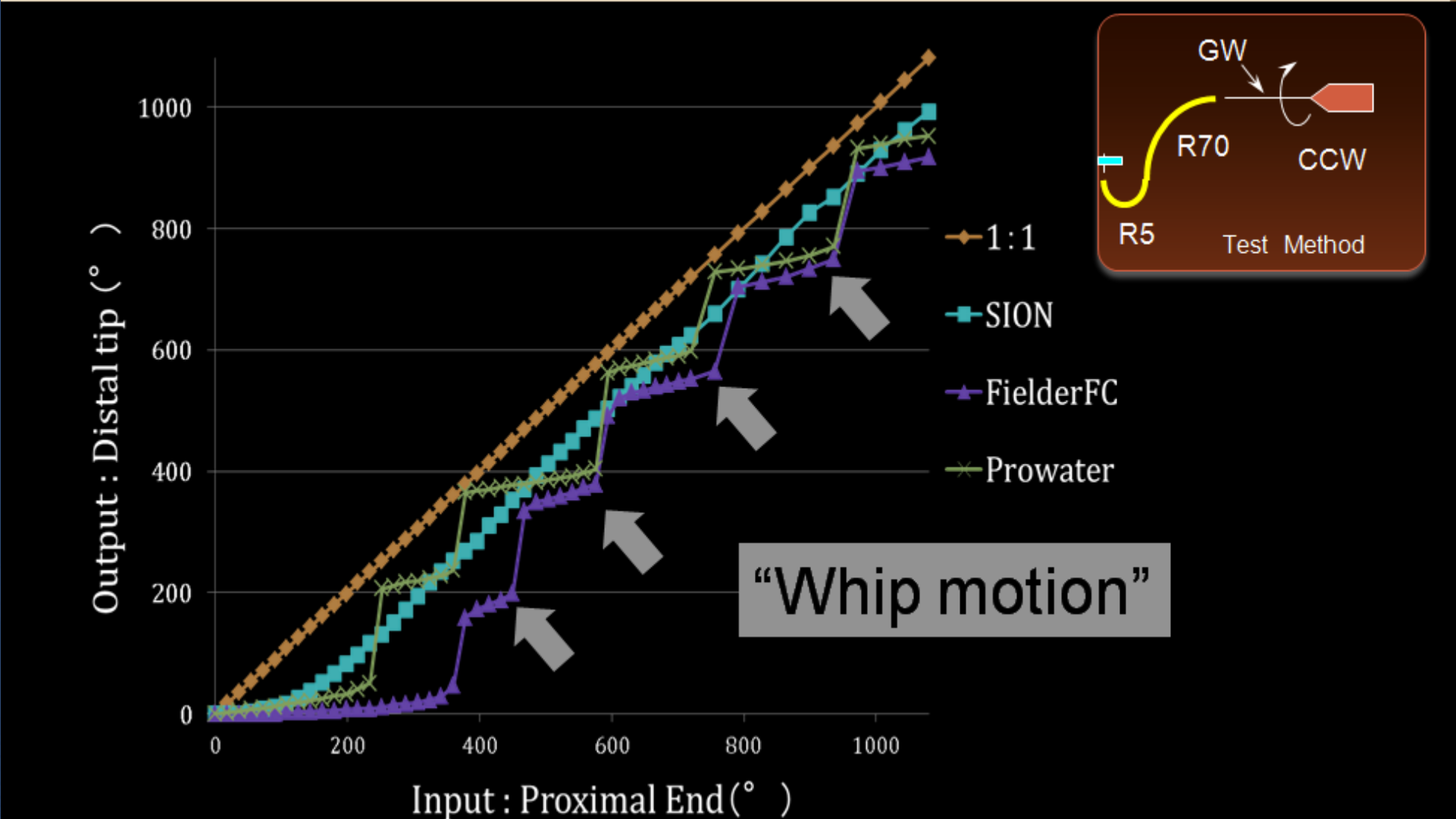

ASAHI SION

Composite Core

By creating the tip from multiple wire components, enhanced durability and torque transmission are possible.

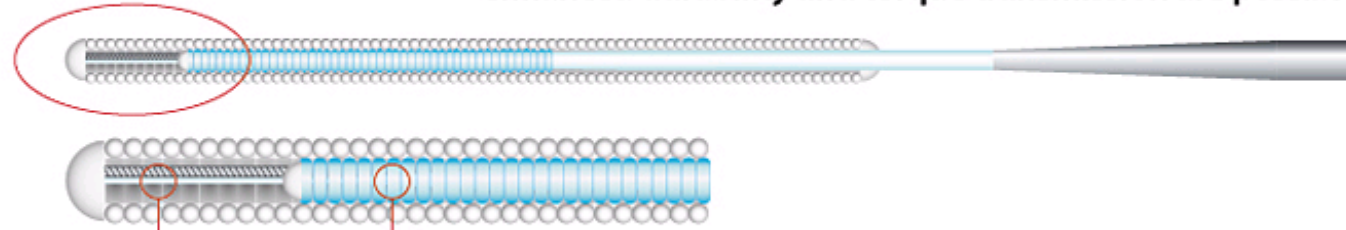

Wire Forming Technology



Employs the ASAHI brand rope coil, which provides torqueability, flexibility, resiliency.

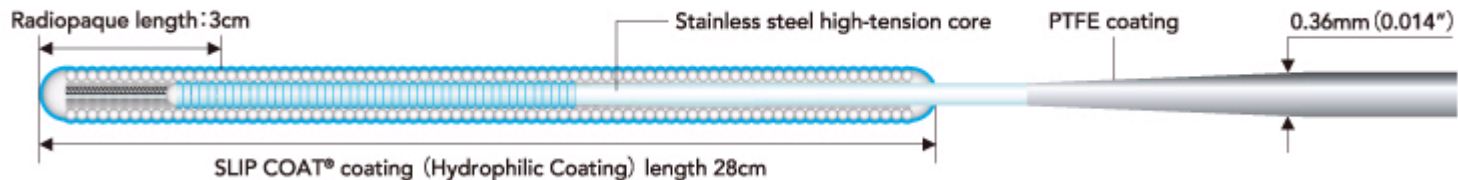

- Durable tip with outstanding shape retention
 - : Possible to treat multiple lesions with one wire
- Advanced torque performance even in extreme tortuosity
 - : Easier vessel selectivity, even after an acute angle
- Flexible shaft and atraumatic tip
 - : Employ the wire in a variety of situations stress-free

ASAHI SION BLUE

SION BLUE

Tip load
0.5g

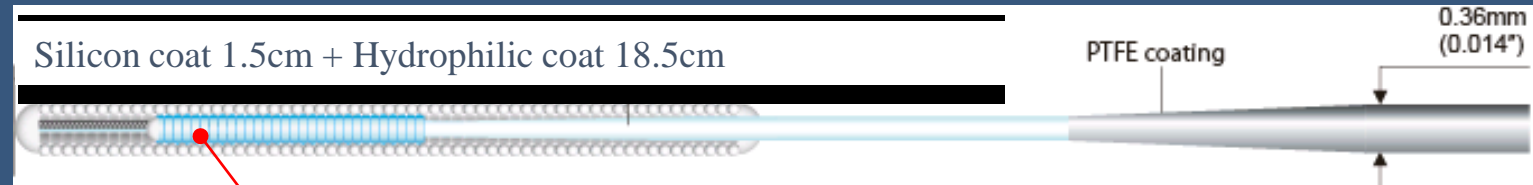

"Composite core"

SION

Tip load
0.7g

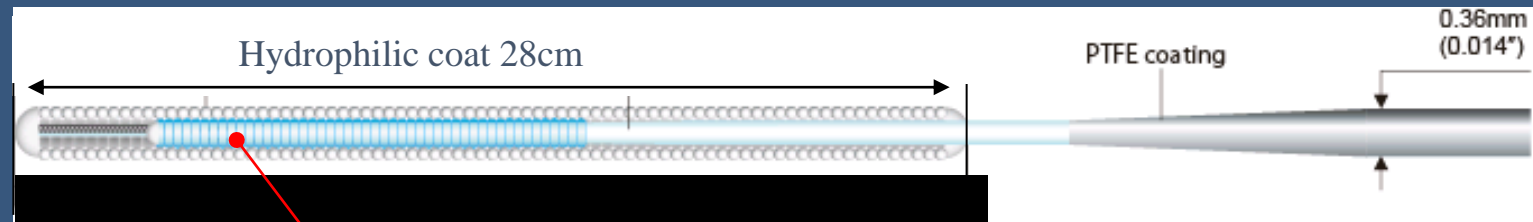

"Composite core"

ASAHI SUHO 03

SUHO 03

Tip load
0.3g



"Composite core"

SION

Tip load
0.7g

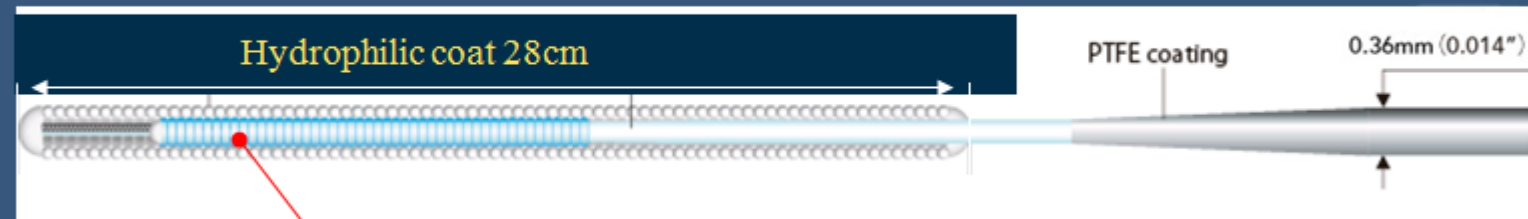

"Composite core"

Development Concept

Fielder
FC

+

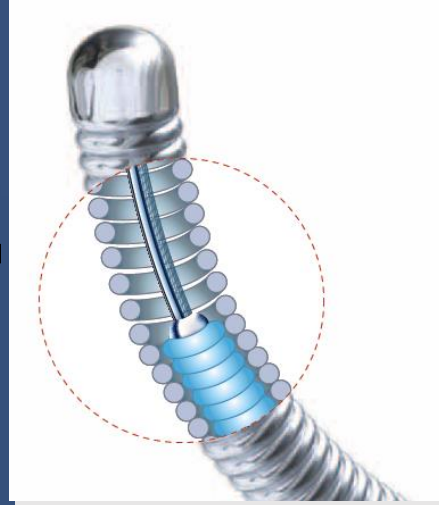

Composite core

ASAHI
SION black
紫苑
PTCA GUIDE WIRE

Line-up addition to the
SION series utilizing
the advantages of both
products

SION

+

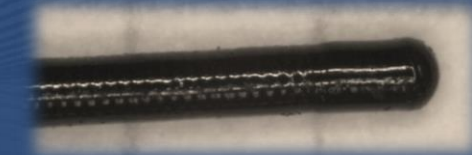

Polymer jacket

SION black Structure

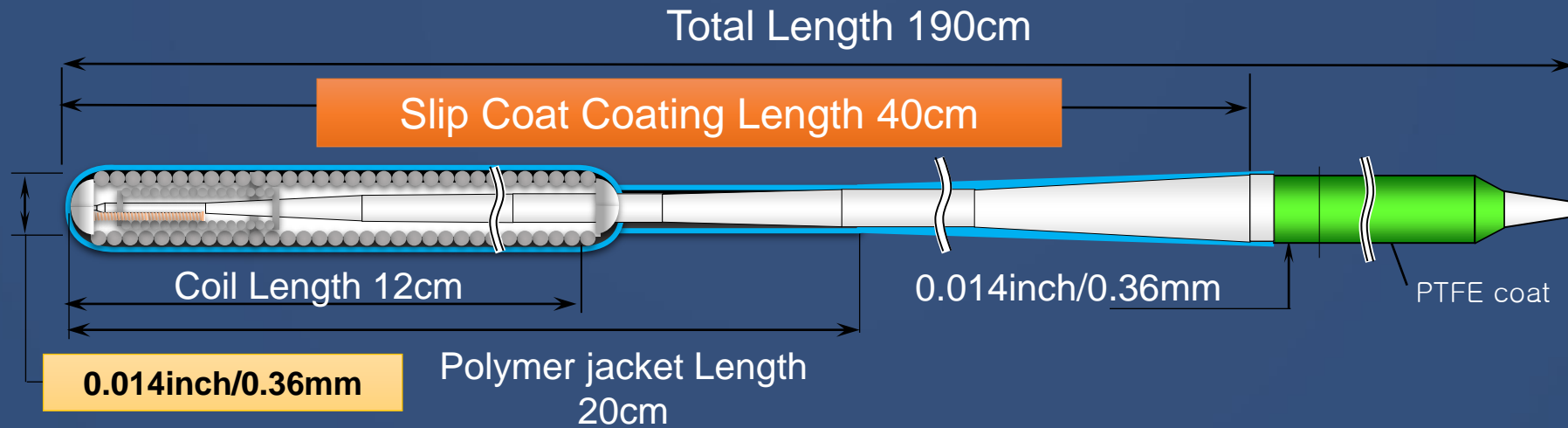

Smooth trackability and high device maneuverability for retrograde approach

SION black

Diameter : 0.014"/0.36mm

Tip loads : 0.8gf

Coating length : 40cm

Usable length : 190cm

Long hydrophilic coating provides smooth manipulation when used with a support catheter such as Corsair

Shaping of the Wire Tip

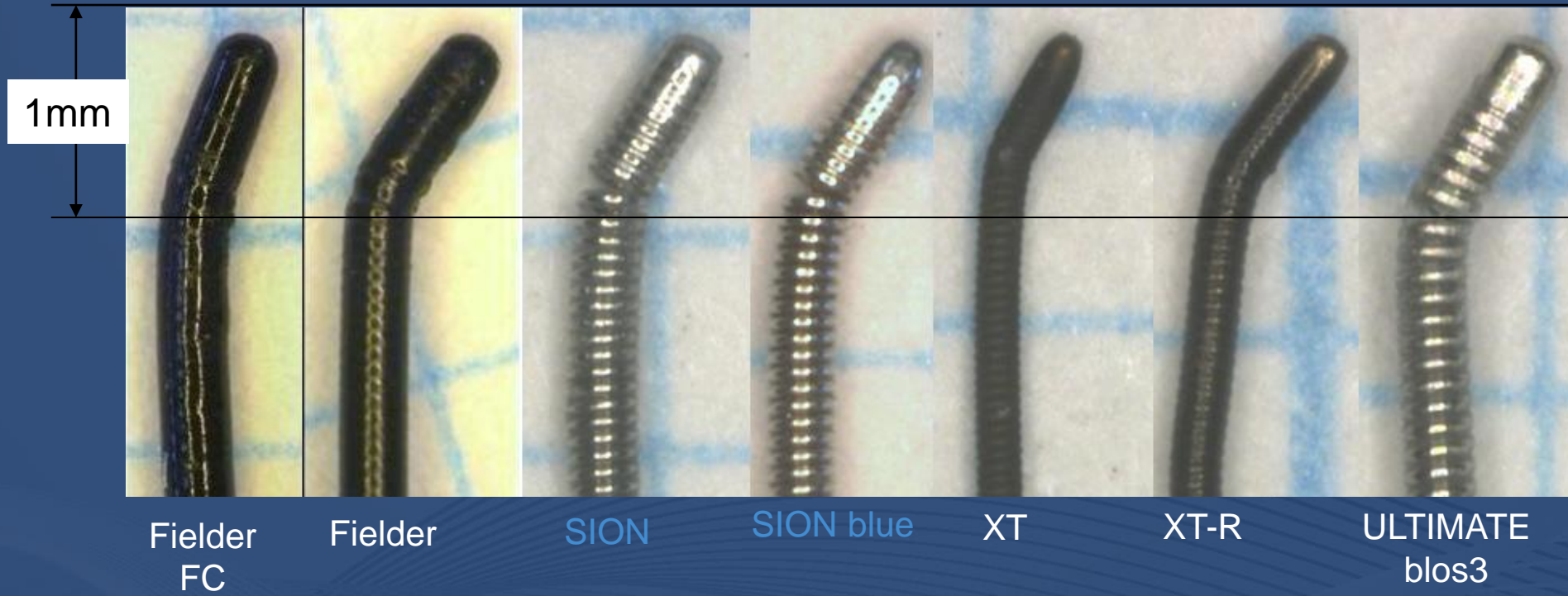

Tip Flexibility

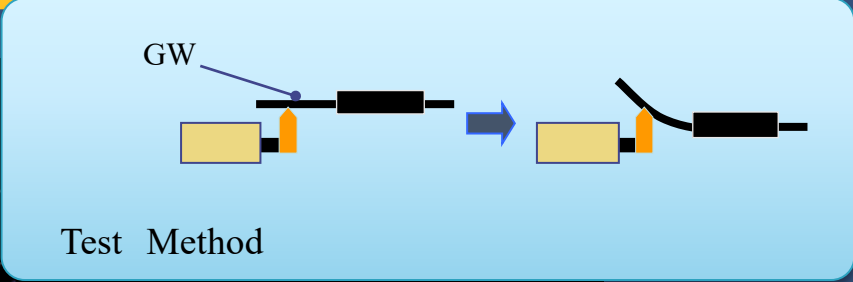

Tip flexibility (gf)

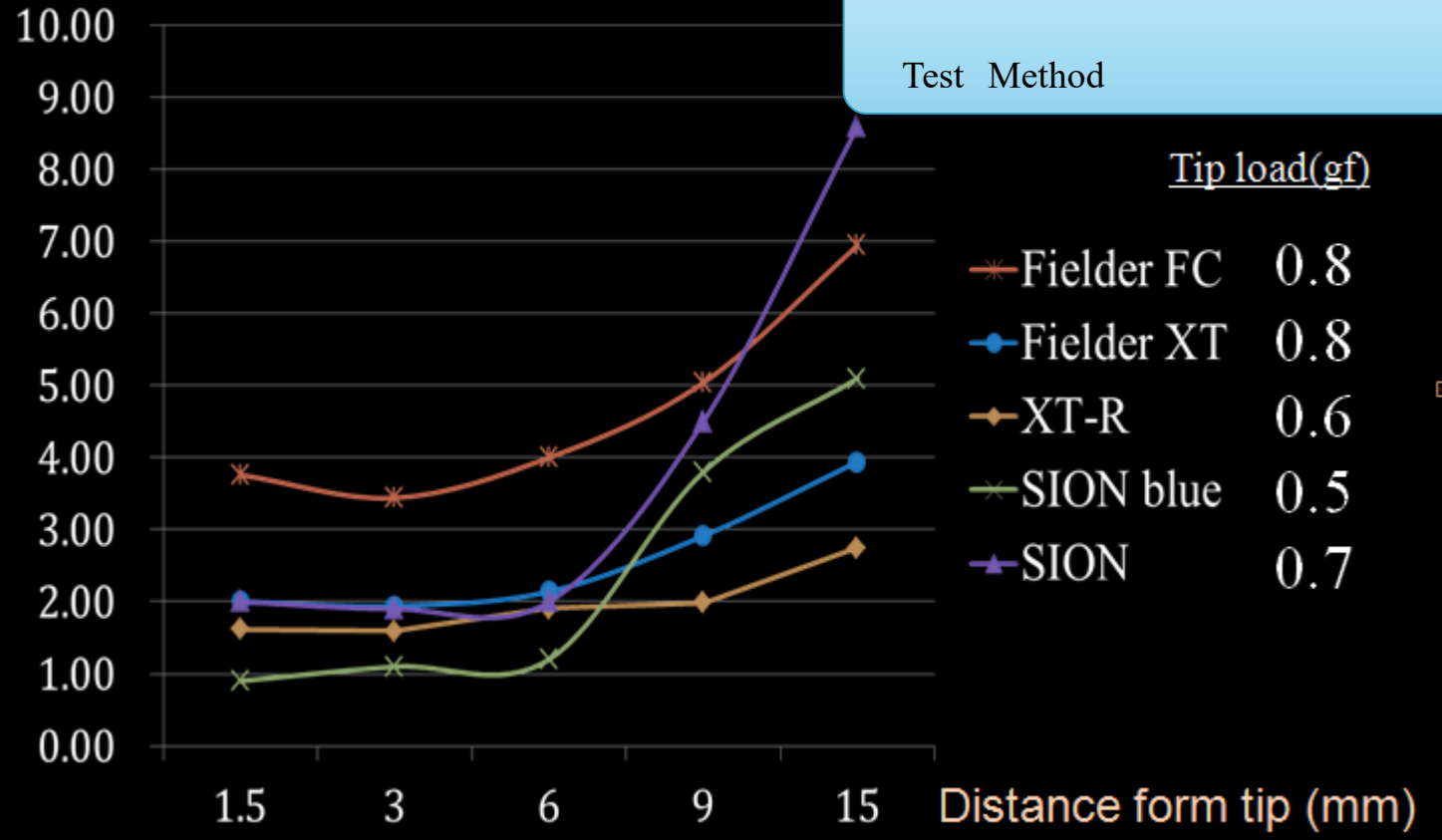

ASAHI Gaia Family

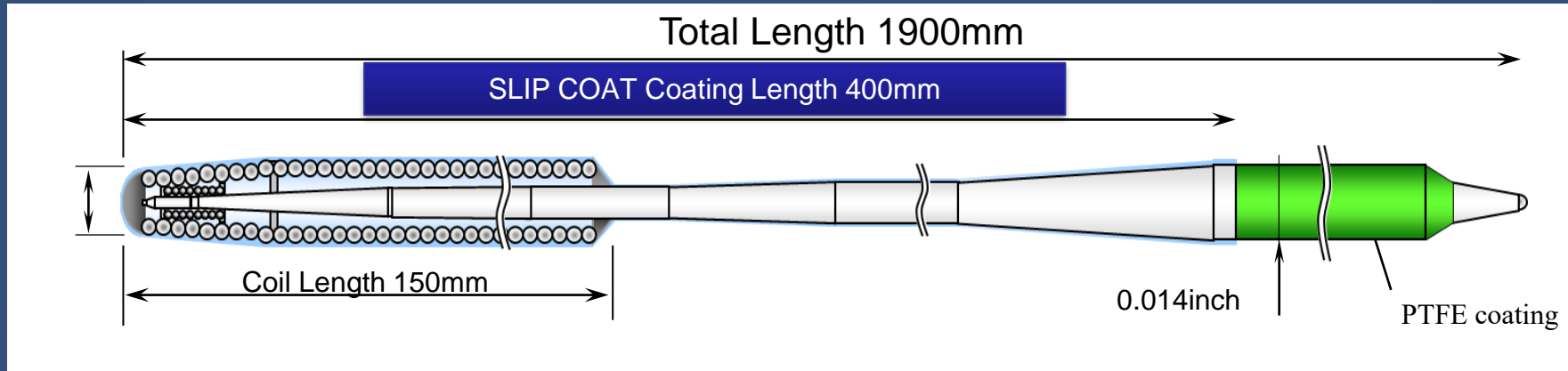

Various models for different situations and/or lesions

ASAHI Gaia First

Diameter : 0.26mm (0.010") - 0.36mm (0.014")
Tip load : 1.7gf

ASAHI Gaia Second

Diameter : 0.28mm (0.011") - 0.36mm (0.014")
Tip load : 3.5gf

ASAHI Gaia Third

Diameter : 0.30mm (0.012") - 0.36mm (0.014")
Tip load : 4.5gf

Coated with hydrophilic coating which enhances smooth controllability inside the micro catheter

ASAHI Gaia Family

Basic Structure

Gaia First : 0.26mm (0.010inch)
Gaia Second : 0.28mm (0.011inch)
Gaia Third : 0.30mm (0.012inch)

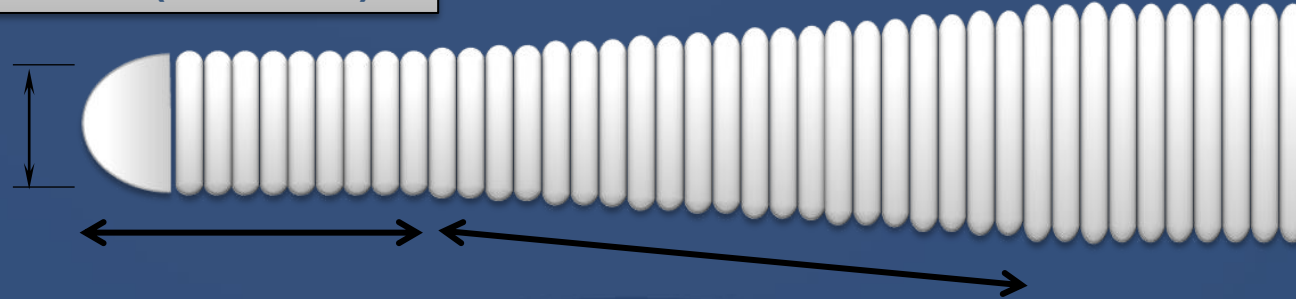

	Straight	Tapered
Gaia First	15mm	30mm
Gaia Second	6mm	30mm
Gaia Third	7mm	30mm

ASAHI Gaia concept

Chronic Occlusion

Micro-cone tip

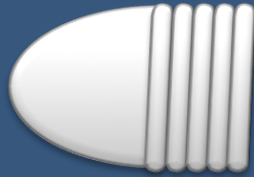

Smooth entry into the occluded lesion

Composite core

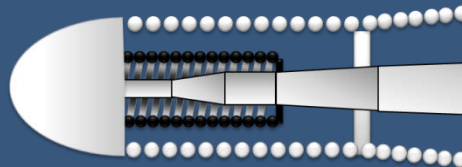

Easy control within the lesion

Maintains shaping memory within the lesion

1mm Mini-pre shape

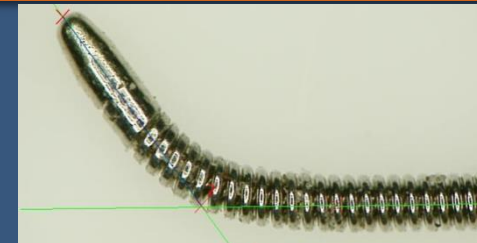

ASAHI Gaia micro cone-tip

The ball tip was made smaller to increase its penetration efficacy while maintaining tip flexibility.

ASAHI Gaia micro-cone tip

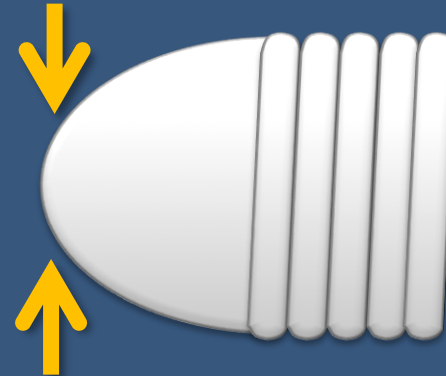

Conventional wire tip

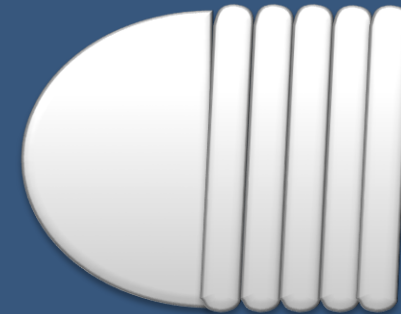

Penetration efficacy

ASAHI Gaia series :
Maintains flexibility while
keeping penetration efficacy

Penetration efficacy

Ease of entering the lesion

→ It is possible to calculate penetration efficacy with the outer diameter of the tip and the tip load.

→ The Gaia GW possesses more penetration efficacy with its smaller outer diameter tip and higher tip load.

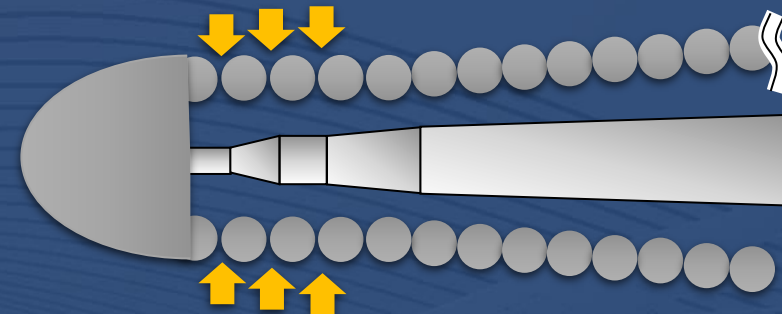
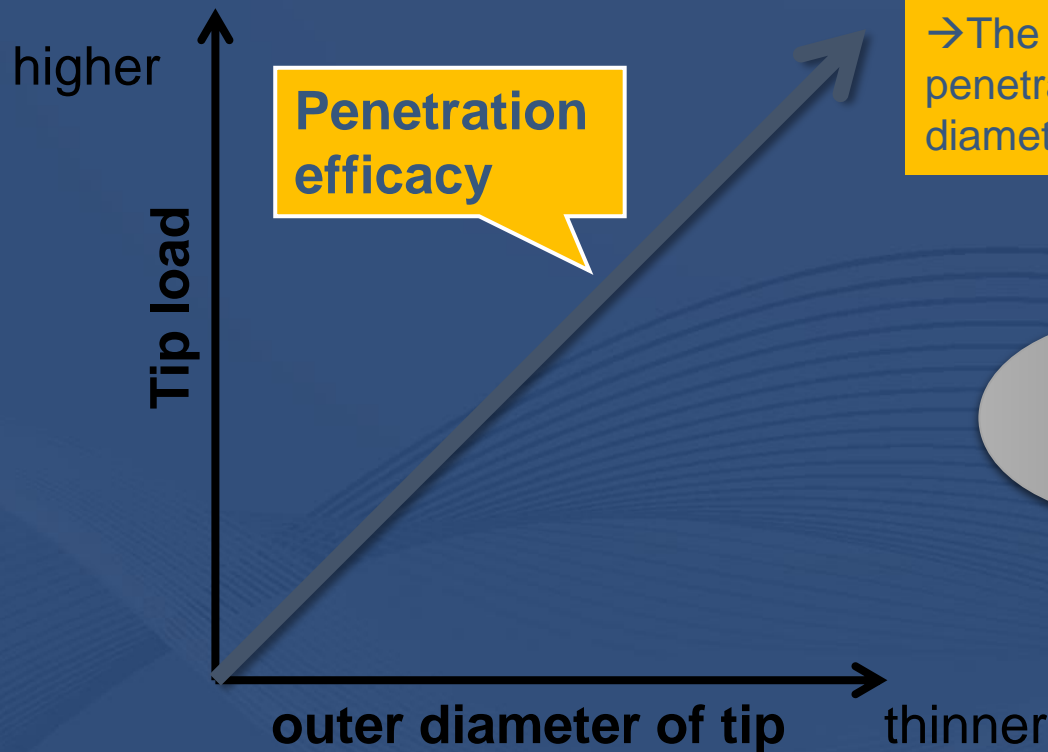

ASAHI Gaia specification/structure/performance

Tip flexibility

Tip flexibility
→ Flexibility of the lateral movement.

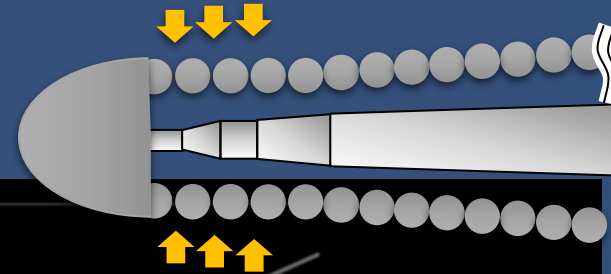

Stiffer

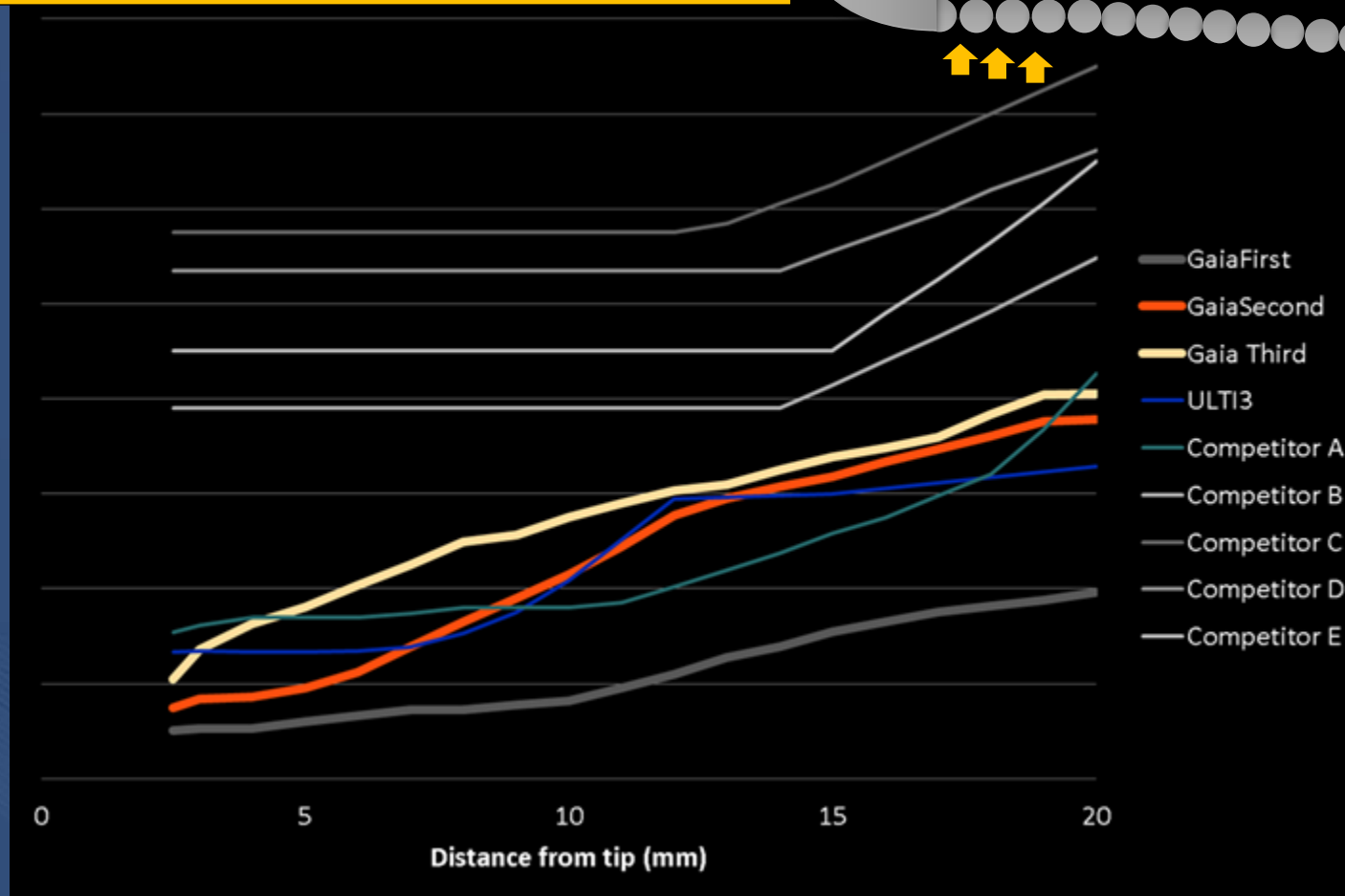

Tip Structure

Composite core : Double Coil Structure

Composite core

Strong torque and tip flexibility are possible by implementing the ACTONE double coil structure.

Suppresses whip motion.



wire drawing, wire forming, and torque improvement. ACTONE™, a flexible stainless steel tube manifests excellent torque characteristics, kink resistance, compression resistance and shape recovery characteristics.

ACTONE

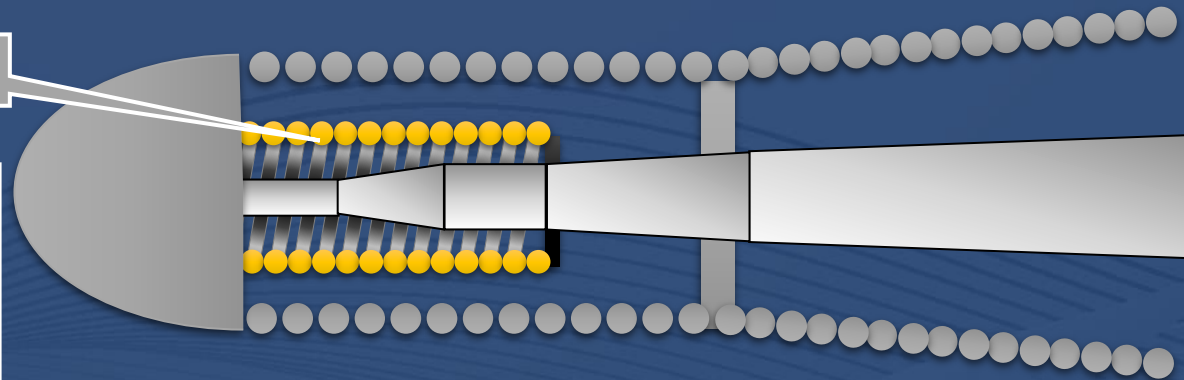

ASAHI Gaia

Torque response - Whip

Within strong resistance area, ASAHI Gaia experiences higher torque response and less whip motion.

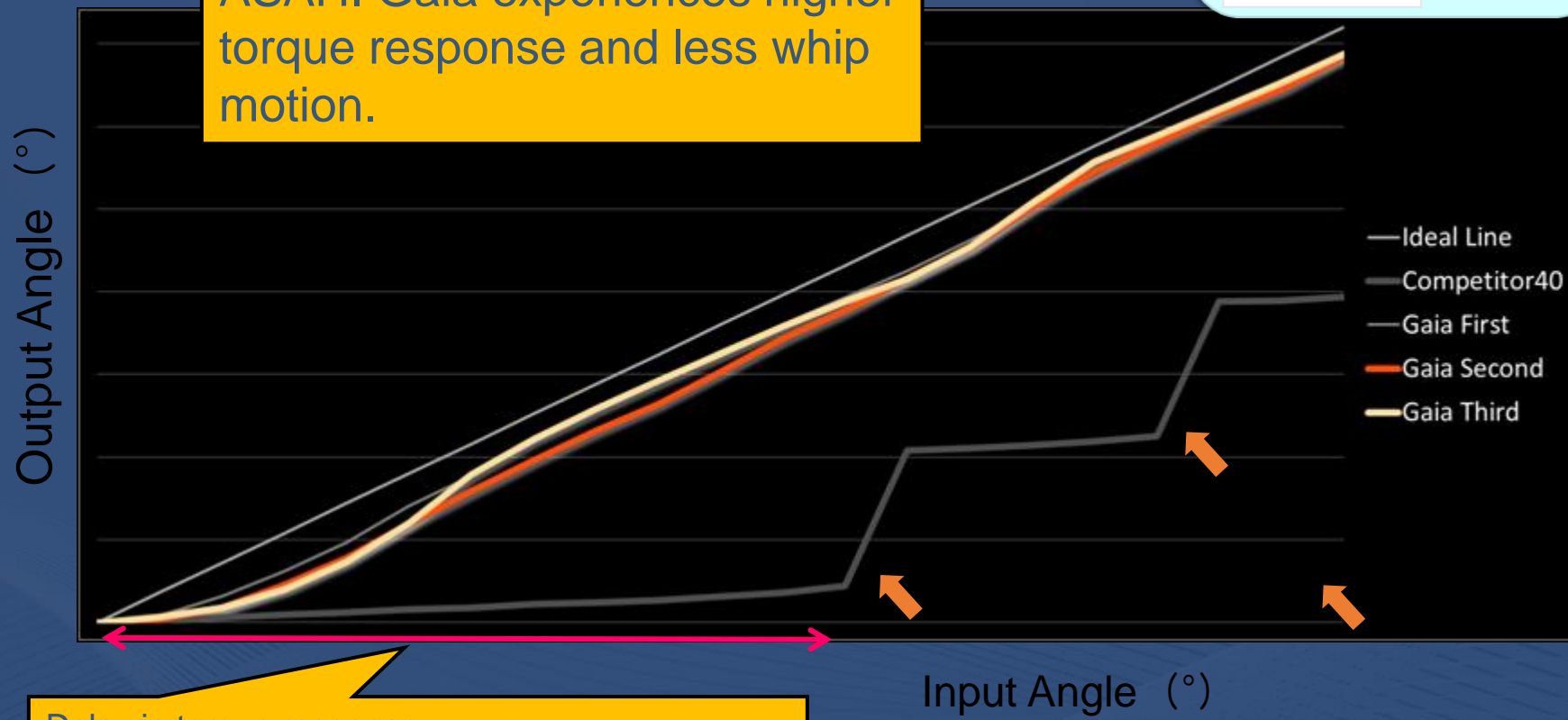
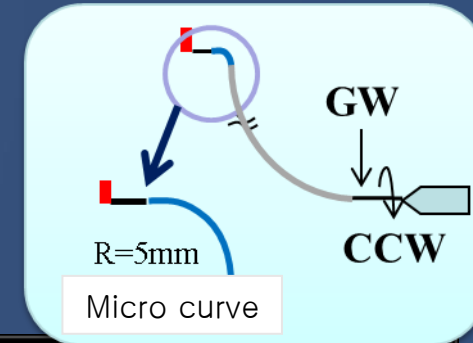

Delay in torque response
When proximal shaft is rotated, tip does not respond

ASAHI Gaia Next Series

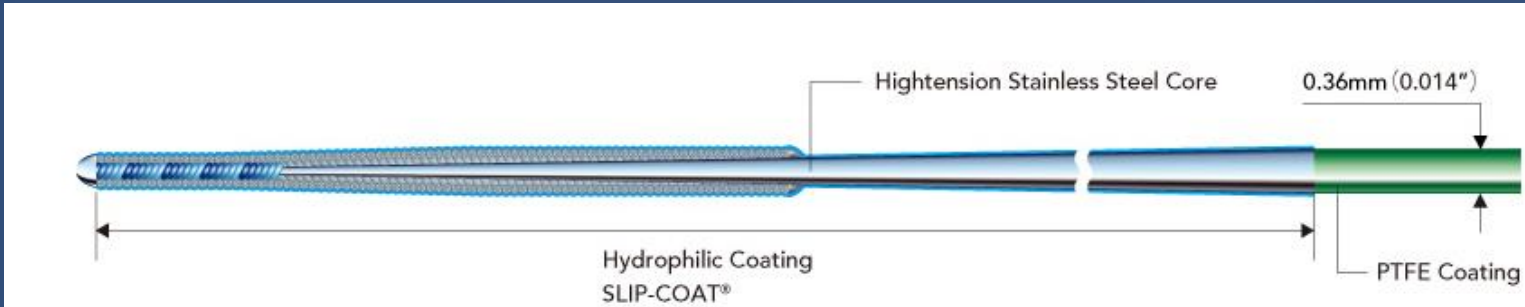

Product	Catalog No.	Diameter	Coating	Usable length	Coil length	Radiopaque length	Tip shape	Label color	Clip color
ASAHI Gaia Next 1	AH14R019P	0.36 / 0.27mm (0.014 / 0.011inch)	Hydrophilic coating (SLIP-COAT®) 40cm	190cm	15cm	15cm	1mm pre-shape	Grey	Grey
ASAHI Gaia Next 2	AH14R020P	0.36 / 0.30mm (0.014 / 0.012inch)	Hydrophilic coating (SLIP-COAT®) 40cm	190cm	15cm	15cm	1mm pre-shape	Blue	Blue
ASAHI Gaia Next 3	AH14R021P	0.36 / 0.30mm (0.014 / 0.012inch)	Hydrophilic coating (SLIP-COAT®) 40cm	190cm	15cm	15cm	1mm pre-shape	Dark Blue	Dark Blue

Gaia Tip ~ 1mm Pre-shape

The most distal 1mm (approx.) shaped during production, saving the operator the difficulty of manual shaping.

: Possible to increase the angle to create a more acute curve manually

: Possible to change re-shape the tip depending on procedural conditions

Pre shape
1mm – approx.45°

Retains shape memory
during procedure

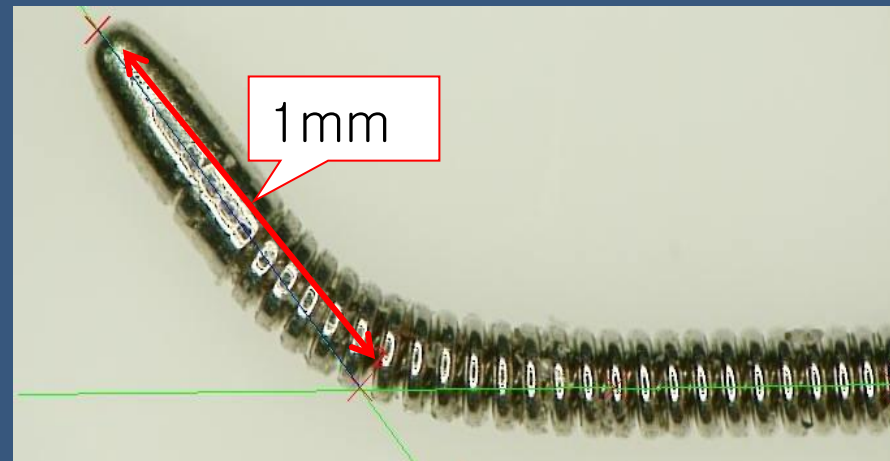

ASAHI Gaia specification/structure/performance

Comparison of Lubricity

Well-balanced lubricity with control

Slip resistance test of the guide wire surface

High
↑ Lubricity ↓
Low

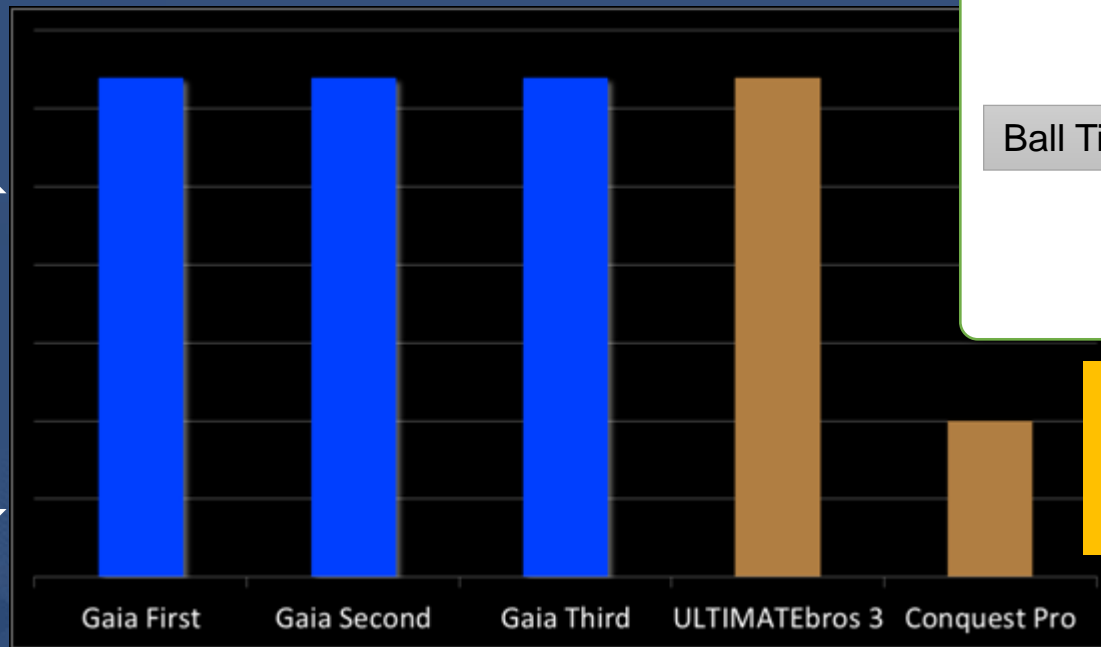

Coating of the guide wire tip

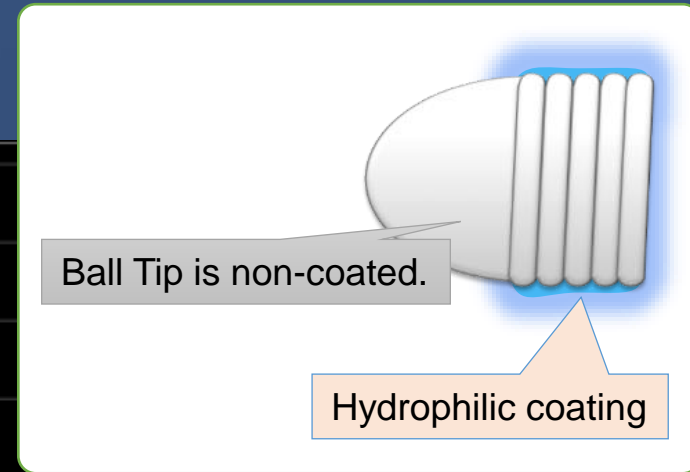

It is easier to access the lesion with a non-coated ball tip

ASAHI Gaia specification/structure/performance

Comparison of Support

Flexible shaft design makes it easier to follow through tortuous vessels and to operate without a delay in torque

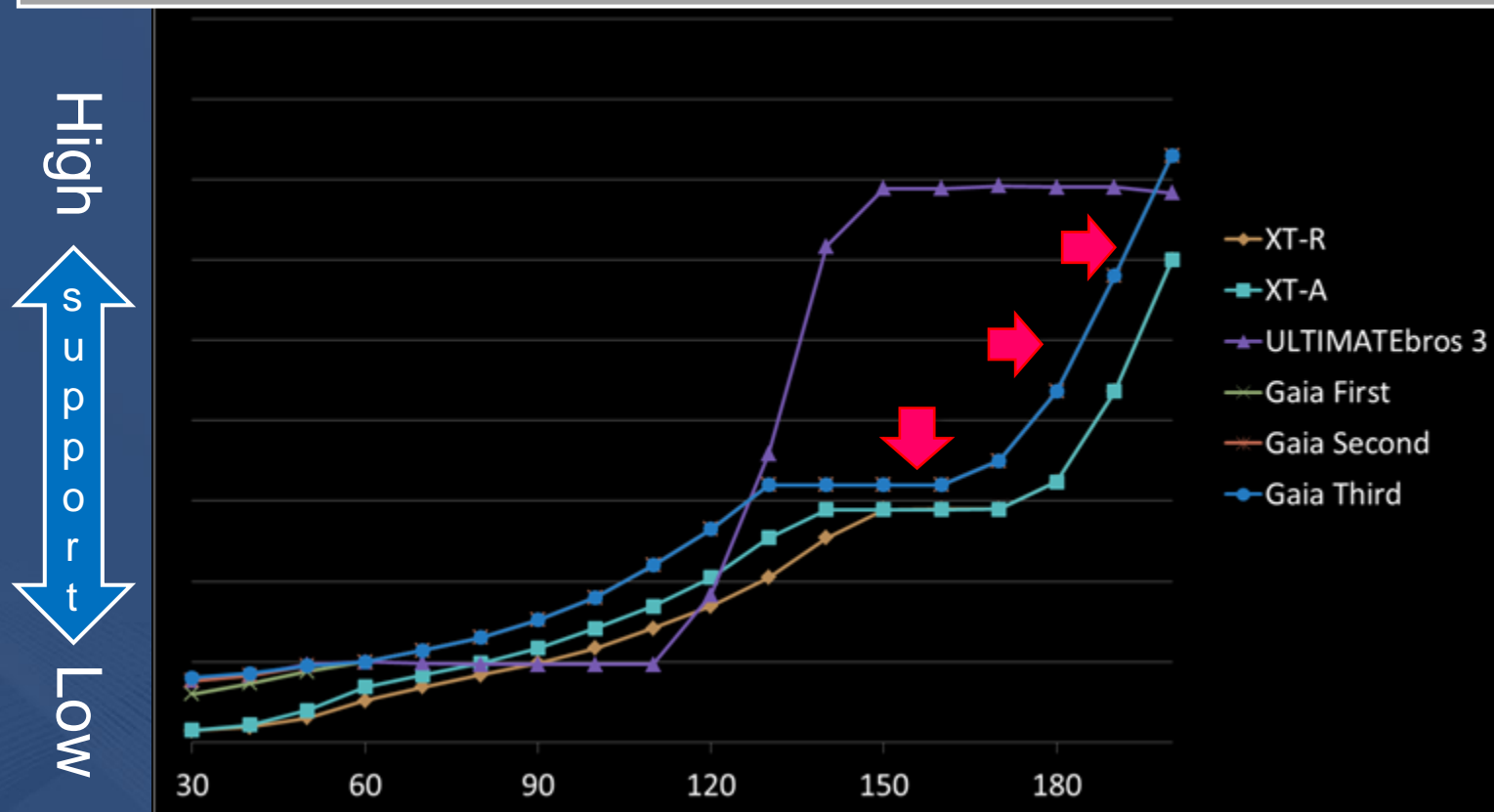

ASAHI Gaia Positioning in GW

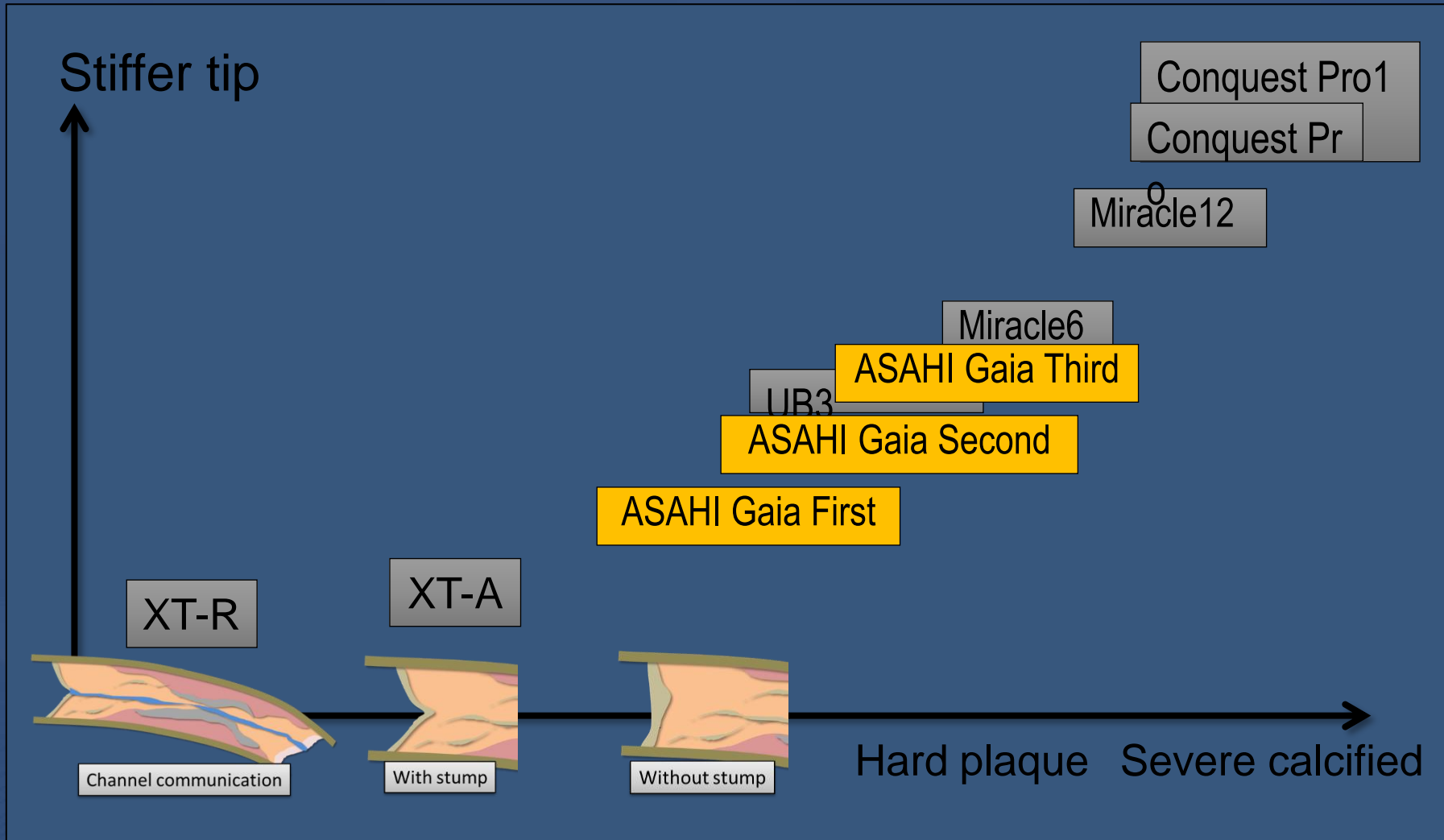

ASAHI CONQUEST Family

PTCA Guide Wires



- Tapered Tip

ASAHI CONQUEST™ 9 – Non hydrophilic

ASAHI CONQUEST PRO™ 9 – SLIP COAT coating

ASAHI CONQUEST PRO™ 12 – SLIP COAT coating

ASAHI CONQUEST TIP LOAD

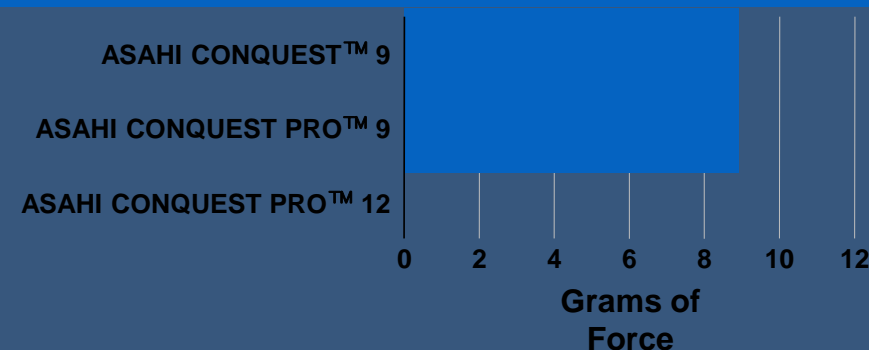

Conquest (Confianza) Pro 9 & 12

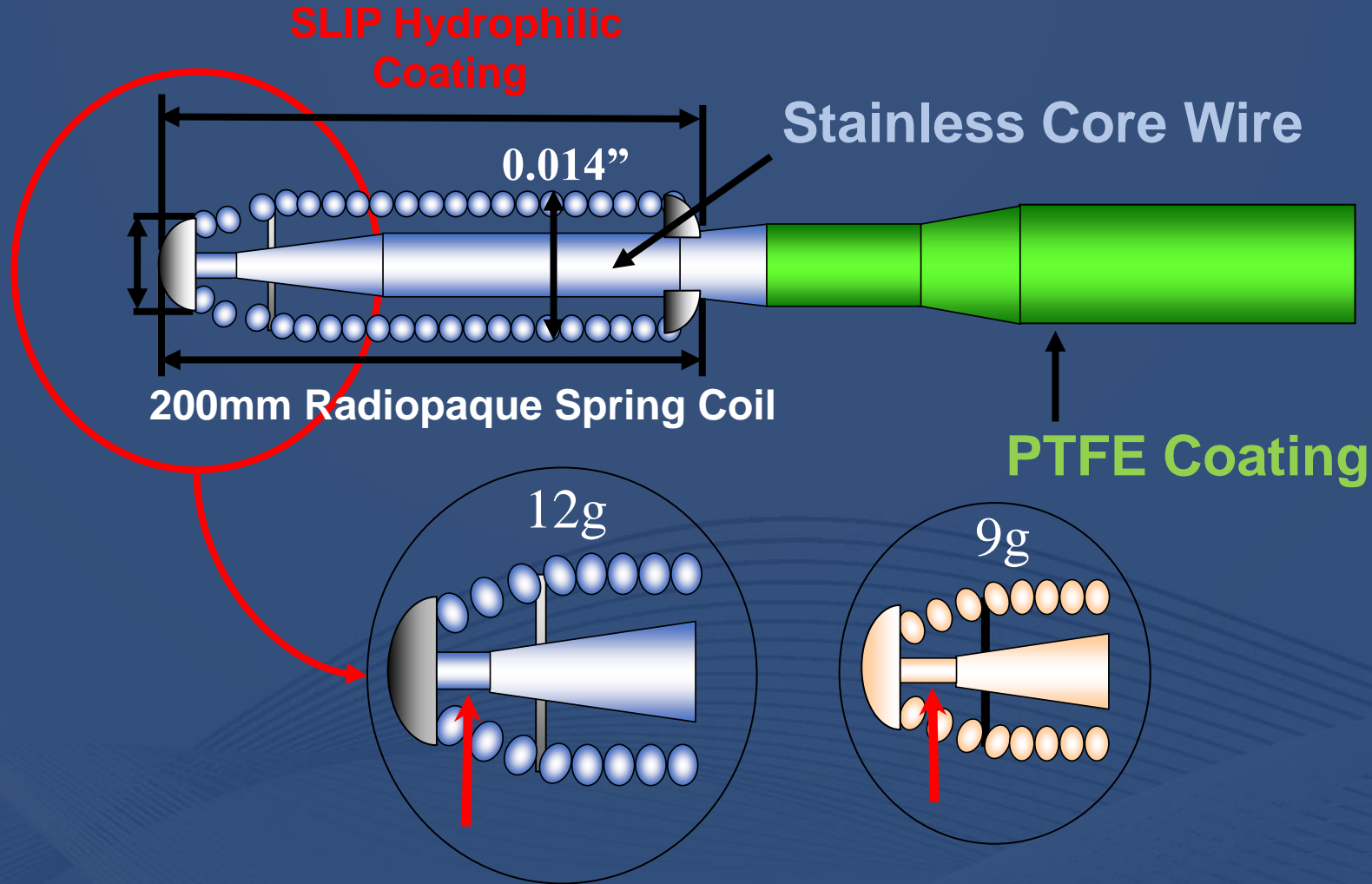

ASAHI CONQUEST Family

Conquest Pro 8-20

Conquest Pro 8-20 AGH143092



- Tip load = 20.0 g
- Tip radiopacity = 17cm
- Tip outer diameter = 0.008 inch (0.20 mm)
- SLIP COAT coating over the spring coil
- PTFE coating over the shaft
- Finest and stiffest guidewire in the current series

ASAHI Gaia vs. Conquest Pro

Core thickness cause differences in penetrability

ASAHI Gaia core design image

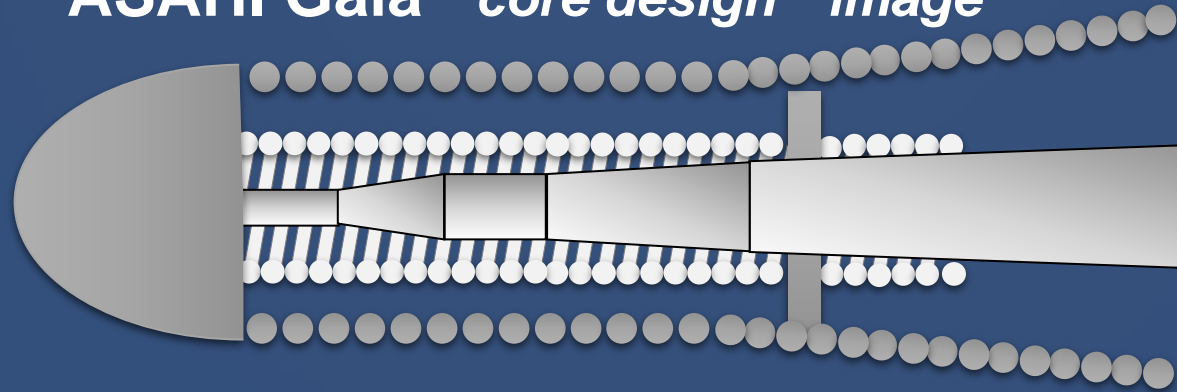

Conquest Pro core design image

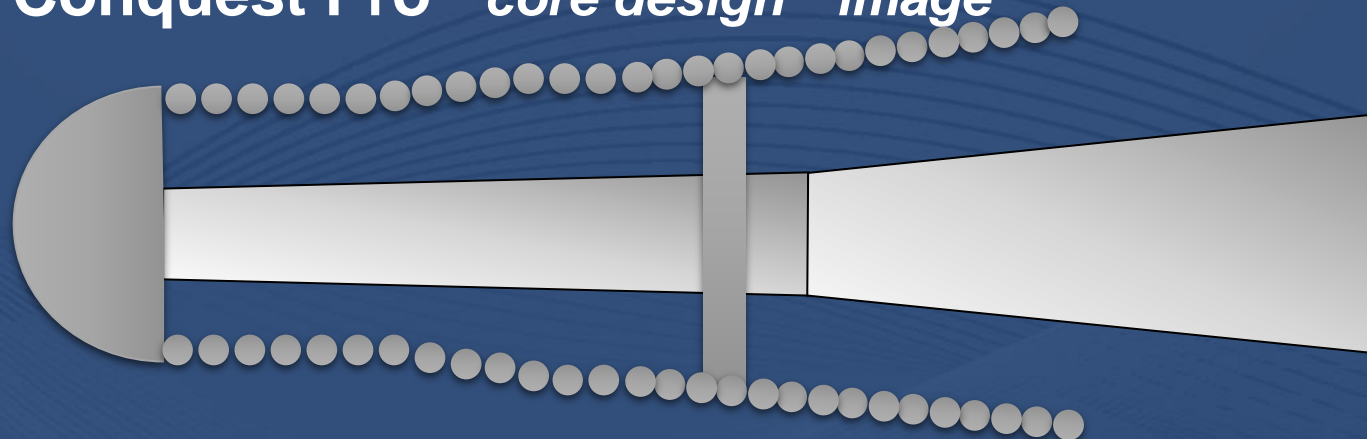

ASAHI Gaia vs. Conquest Pro

Core thickness cause differences in penetrability

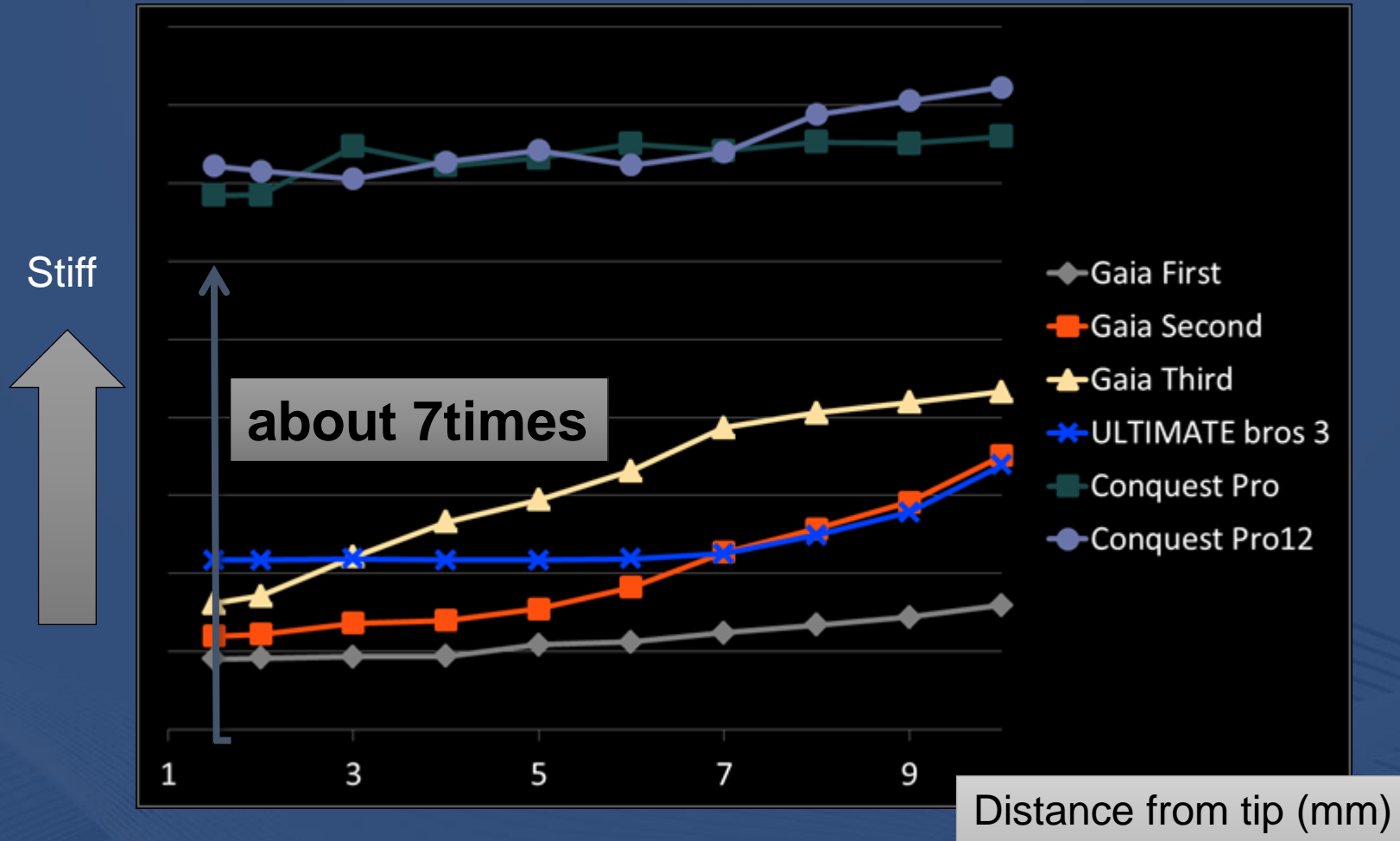

ASAHI RG3

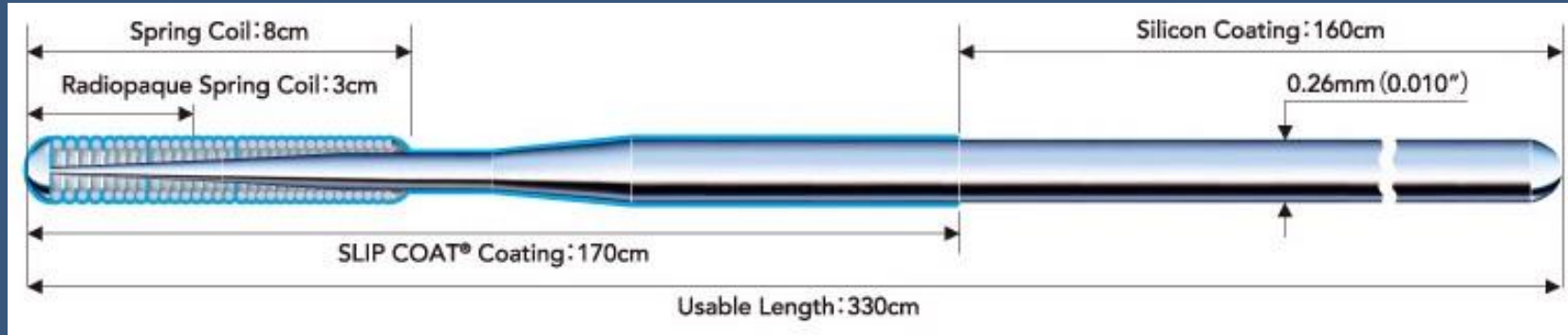

- Optimal wire strength, hydrophilic coating and 0.26 mm shaft provide superior inside-catheter pushability
- With the inner wall damage possibility reduced in tortuous vessels as well, the risk of complication is minimized

Wire for Circumferential Technique for Reverse CART Technique

ASAHI
RG3
PTCA GUIDE WIRE

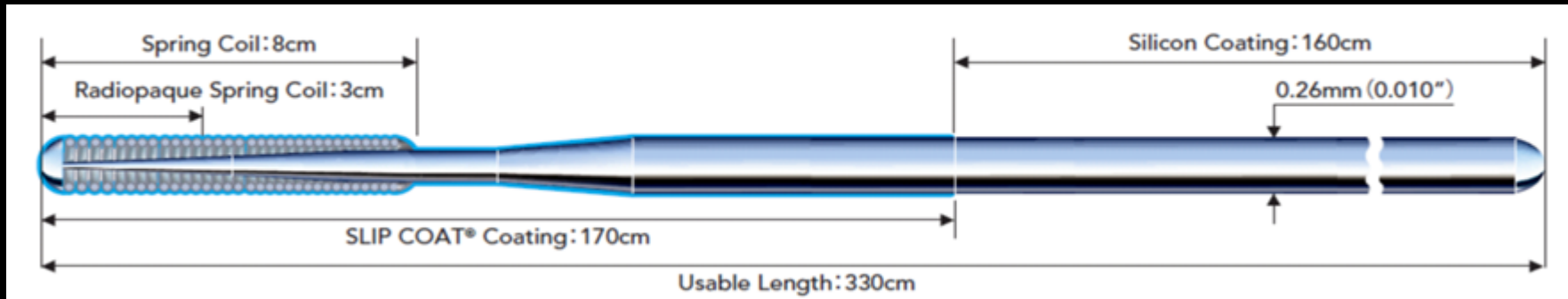

- Tip Load 3.0g
- Coil 8cm
- Diameter 0.010inch
- Length 330cm

Structure of RG3 (RetroGrade300)

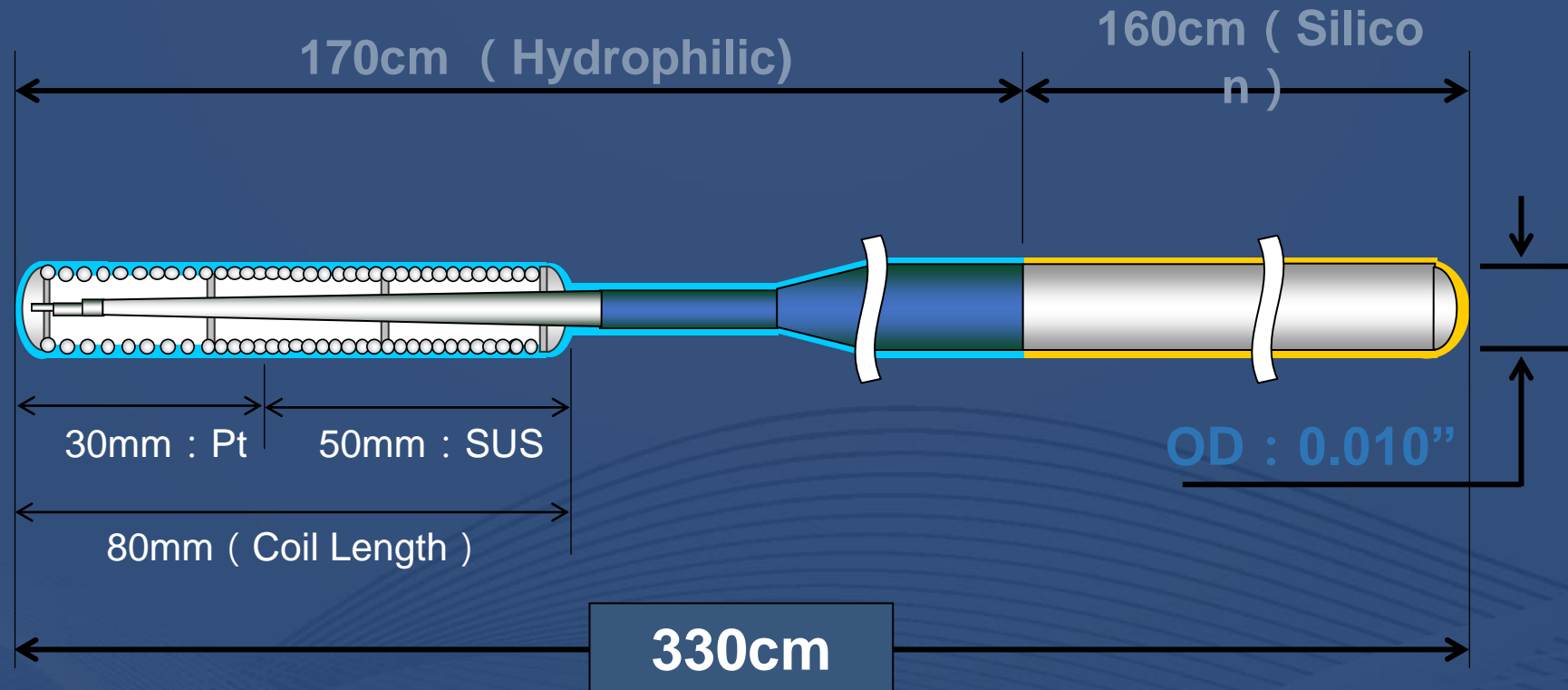

HI-TORQUE ADVANCE™ & ADVANCE LITE™

DURASTEEL™ high tensile strength core material provides durability and superb torque control

Core-to-tip design offers precise steering and tip control



SMOOTHGLIDE™ technology on Proximal Wire for smooth device interaction



RESPONSEASE™ transitionless core grind provides excellent tracking and 1:1 torque response

Support Catheter for CTO

Cosair Pro

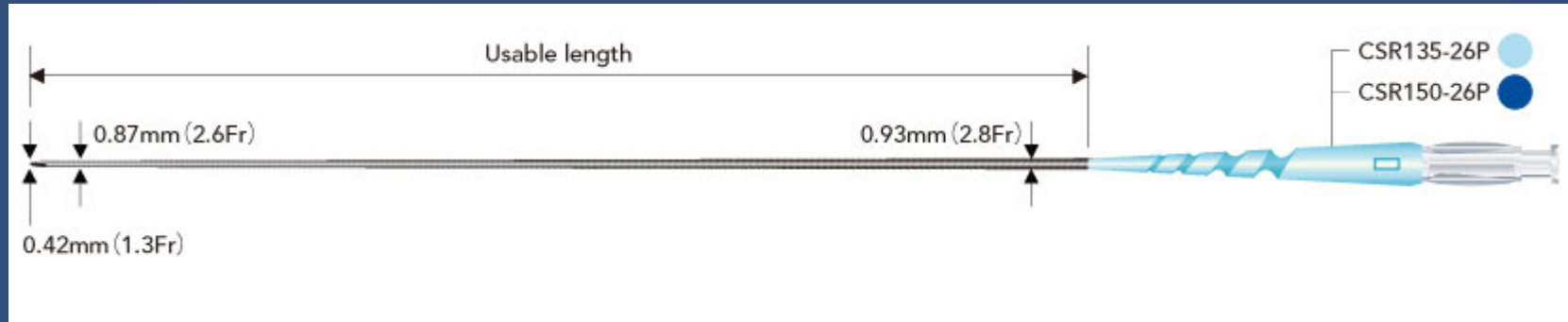

Product	Catalog No.	Outer diameter			Inner diameter		Usable length	Recommended GW
		Tip	Distal shaft	Proximal shaft	Tip	Shaft		
ASAHI	CSR135-26P	0.42mm (1.3Fr)	0.87mm (2.6Fr)	0.93mm (2.8Fr)	0.38mm (0.015inch)	0.45mm (0.018inch)	135cm	0.36mm (0.014inch)
Corsair Pro	CSR150-26P	0.42mm (1.3Fr)	0.87mm (2.6Fr)	0.93mm (2.8Fr)	0.38mm (0.015inch)	0.45mm (0.018inch)	150cm	0.36mm (0.014inch)

- High visibility at the lesion part
- High tracking ability into the lesion
- Entire tip is visible under fluoroscope

Cosair Pro XS

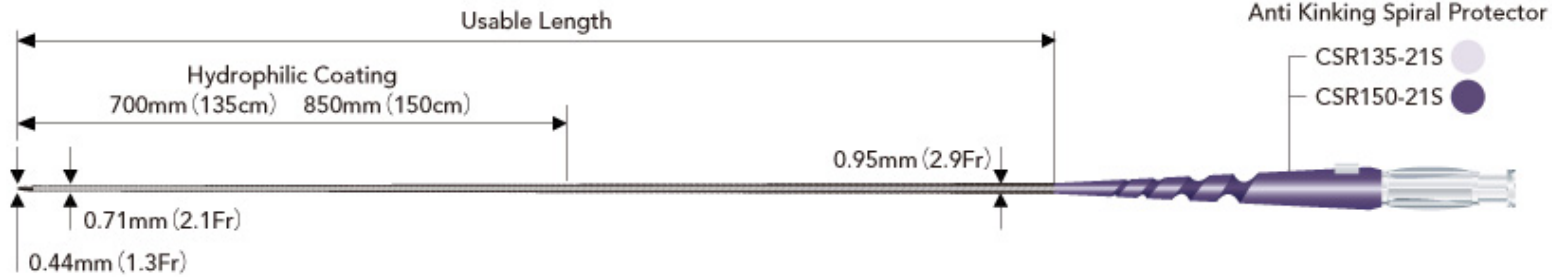

Tip Flexibility

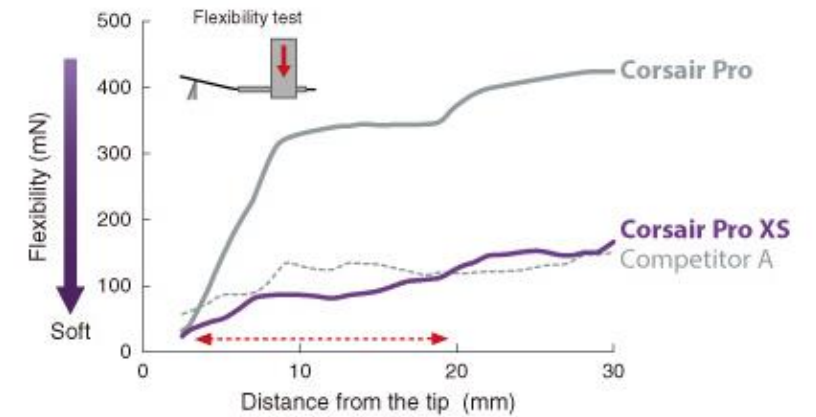

Product	Catalog No.	Outer diameter			Inner diameter		Usable length	Recommended GW
		Tip	Distal shaft	Proximal shaft	Tip	Shaft		
ASAHI	CSR135-21S	0.44mm (1.3Fr)	0.71mm (2.1Fr)	0.95mm (2.9Fr)	0.38mm (0.015inch)	0.48mm (0.019inch)	135cm	0.36mm (0.014inch)
Cosair Pro XS	CSR150-21S	0.44mm (1.3Fr)	0.71mm (2.1Fr)	0.95mm (2.9Fr)	0.38mm (0.015inch)	0.48mm (0.019inch)	150cm	0.36mm (0.014inch)

ASAHI Corsair Microcatheter

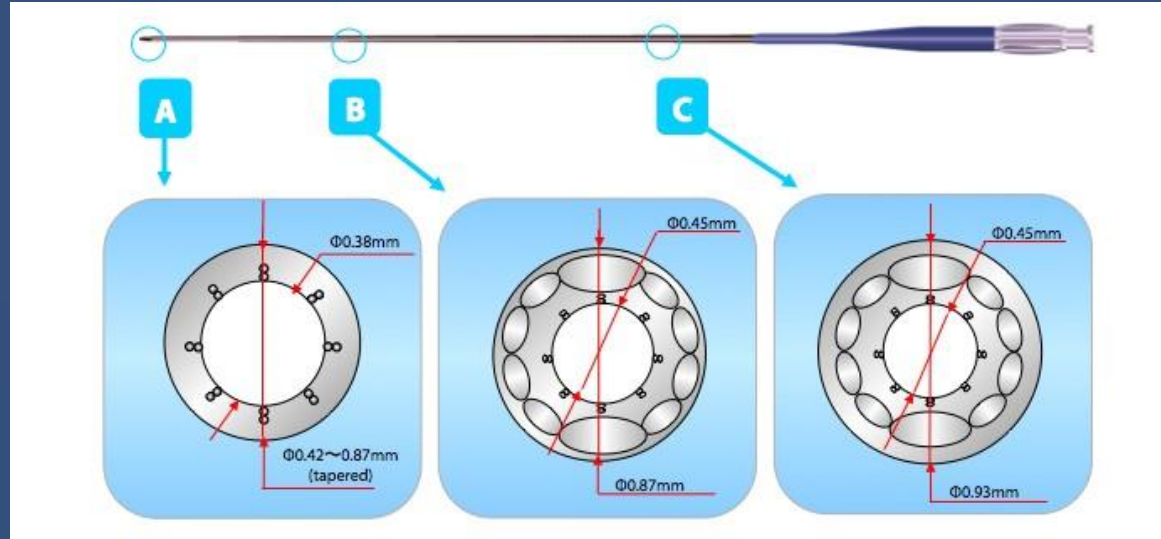

- Tip Flexibility : Tapered Soft Tip
- Pushability, Trackability, Support : SHINKA Shaft
- Lubricity : Hydrophilic Polymer Coating
- Visibility & Maneuverability : Tapered Soft tip and Tungsten Braiding
- Visibility & Maneuverability
- Rigidity and Pushability : Reinforced Tapered Shaft

ASAHI Corsair Microcatheter

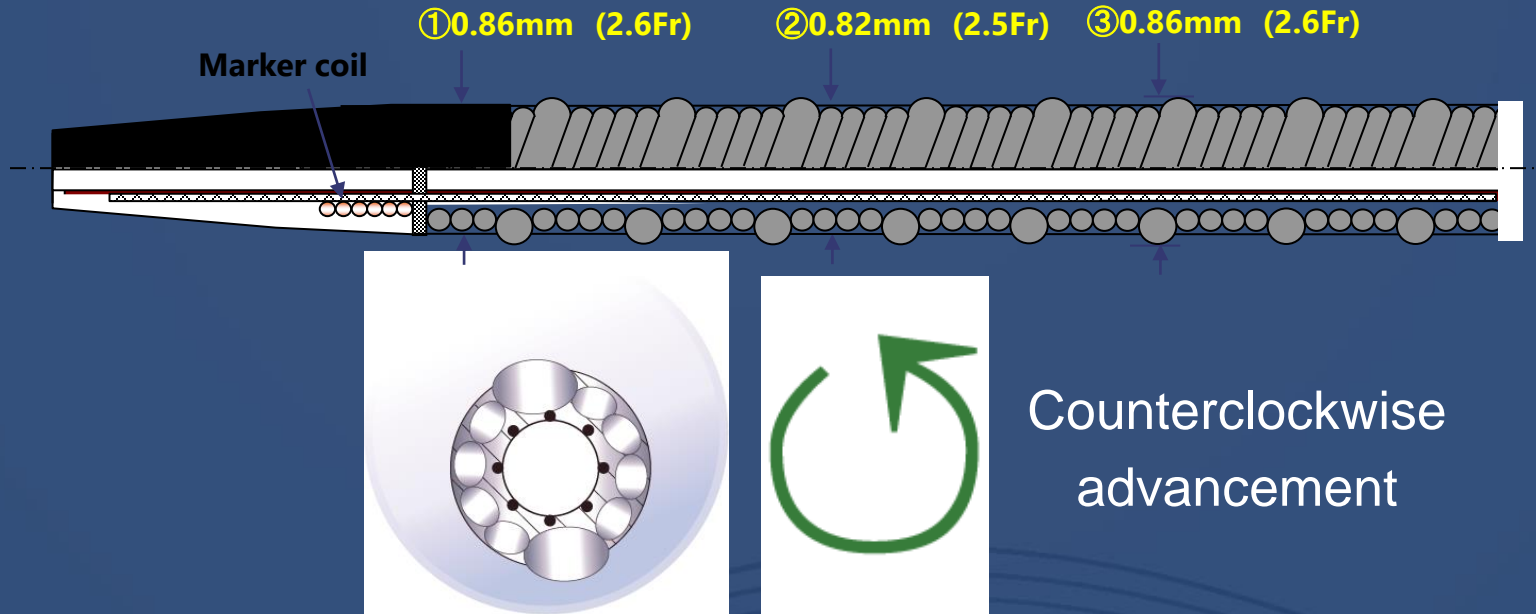

- Tapered Soft Polyurethane Tip
- 20cm Screw Head Structure
- Hydrophilic Polymer Coating
- PTFE Inner Layer

Counterclockwise advancement

ASAHI Corsair Microcatheter

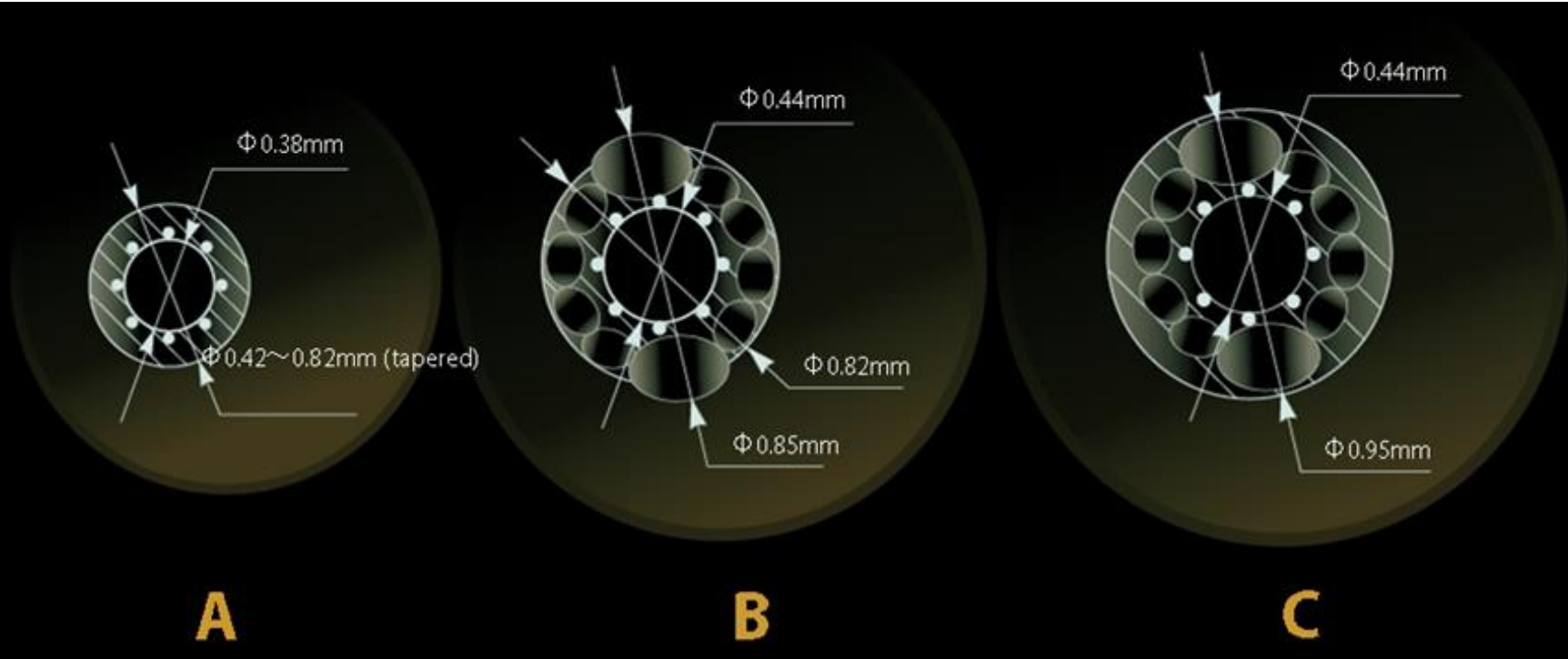

ASAHI Corsair Microcatheter

Very flexible tip

Hydrophilic polymer coating

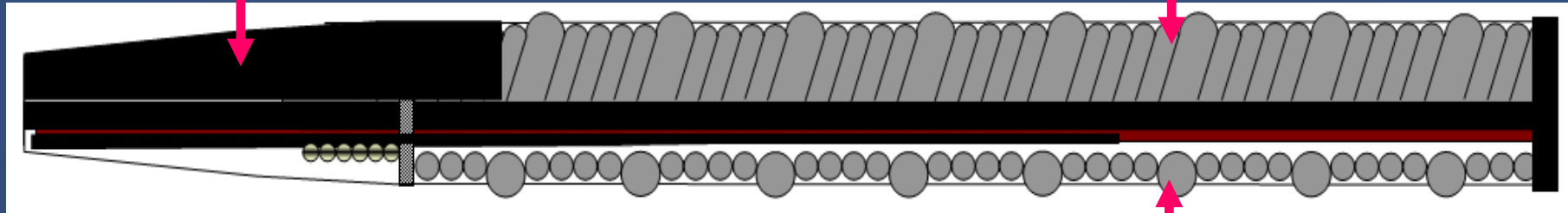

PTFE inner layer

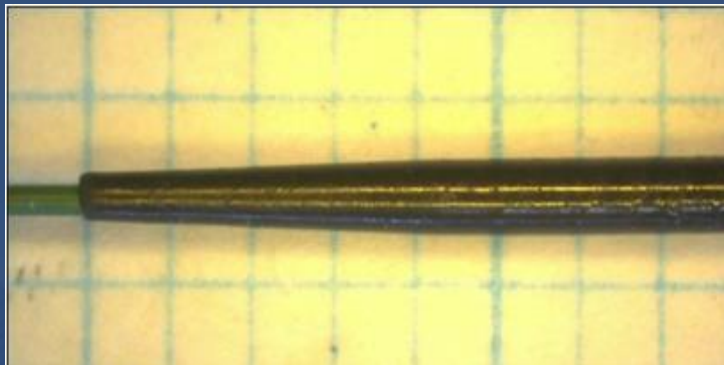

Dimensions of Corsair Catheter

ASAHI
Corsair
Microcatheter

Hydrophilic Polymer Coating 60cm

Length; **135cm** for Antegrade
150cm for Retrograde

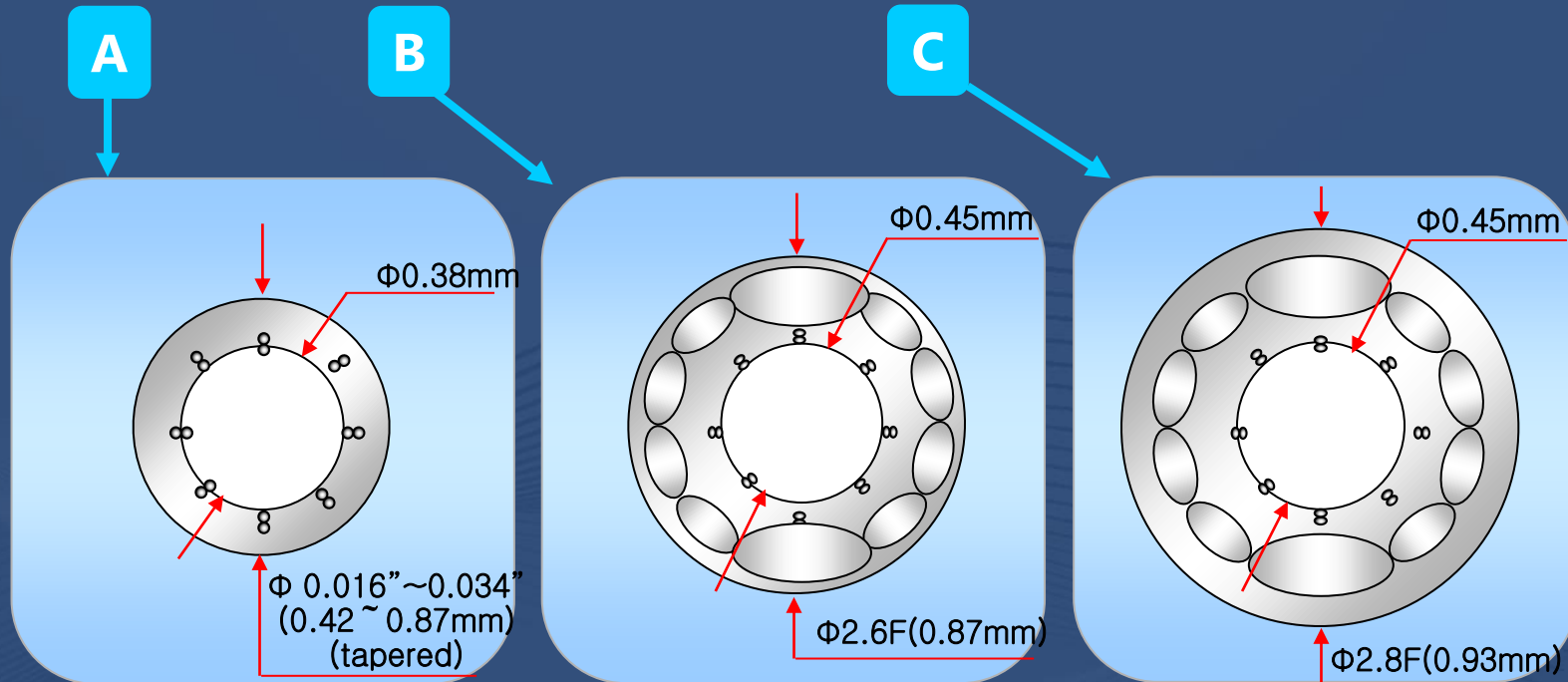
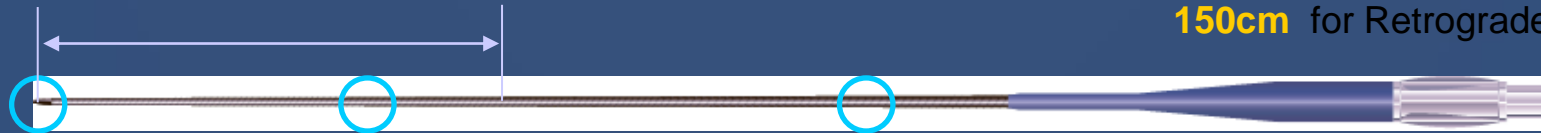

Tip of Corsair Catheter

ASAHI
Corsair
Microcatheter

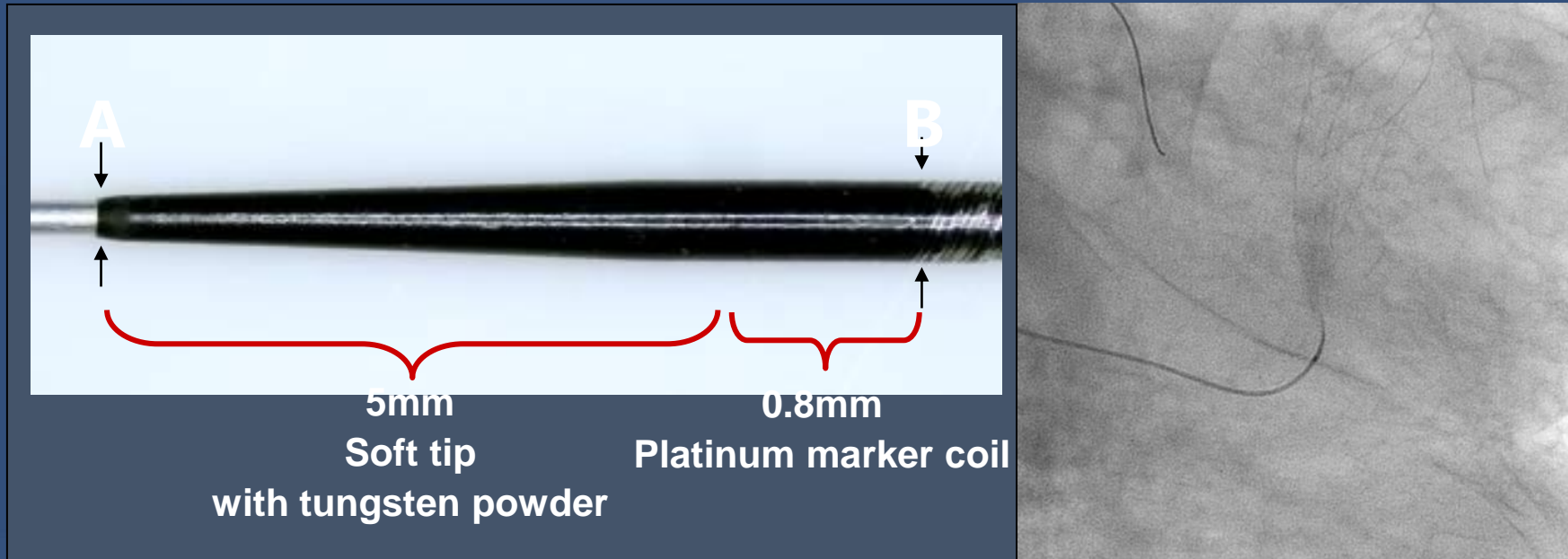

A- Tip entry profile 0.42mm (0.016")
B- Shoulder O.D. 0.87mm (0.034")

R³ Effect **Rotation Resistance Reduction**

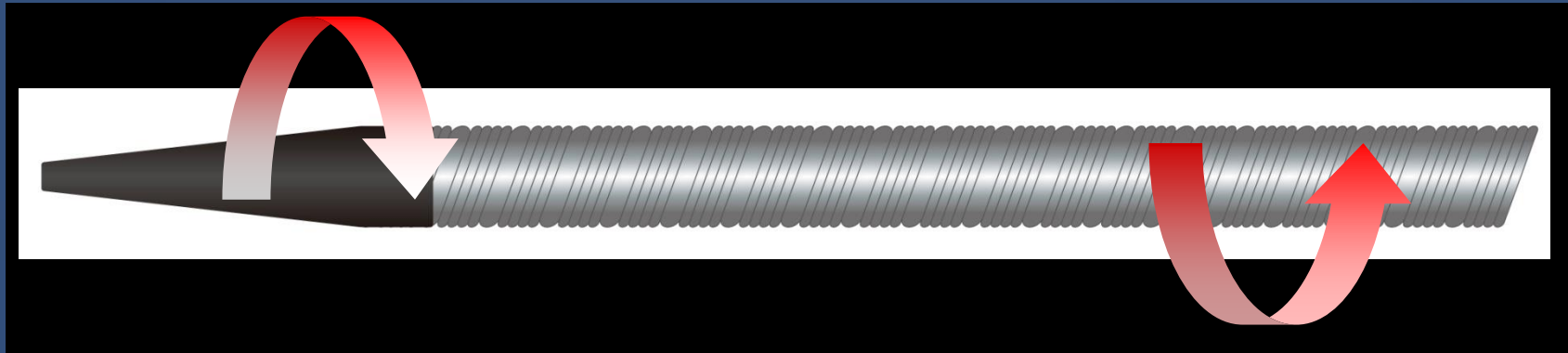

By adding the torque rotation,
it reduces the friction within the vessel and enhances propulsion.

Tip Injury

Calcified Lesion / Stent Strut



Braided tip; visual exam and x-ray



Tip Injury

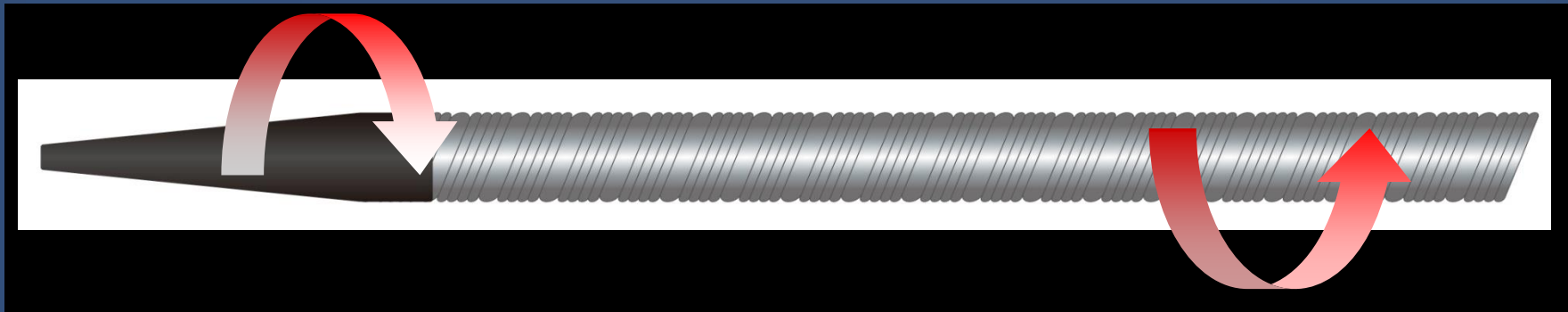
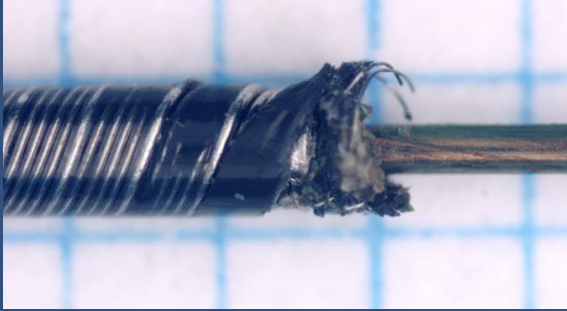

To take turns CWR and CCWR

To avoid too much rotation (>10)

ASAHI SASUKE

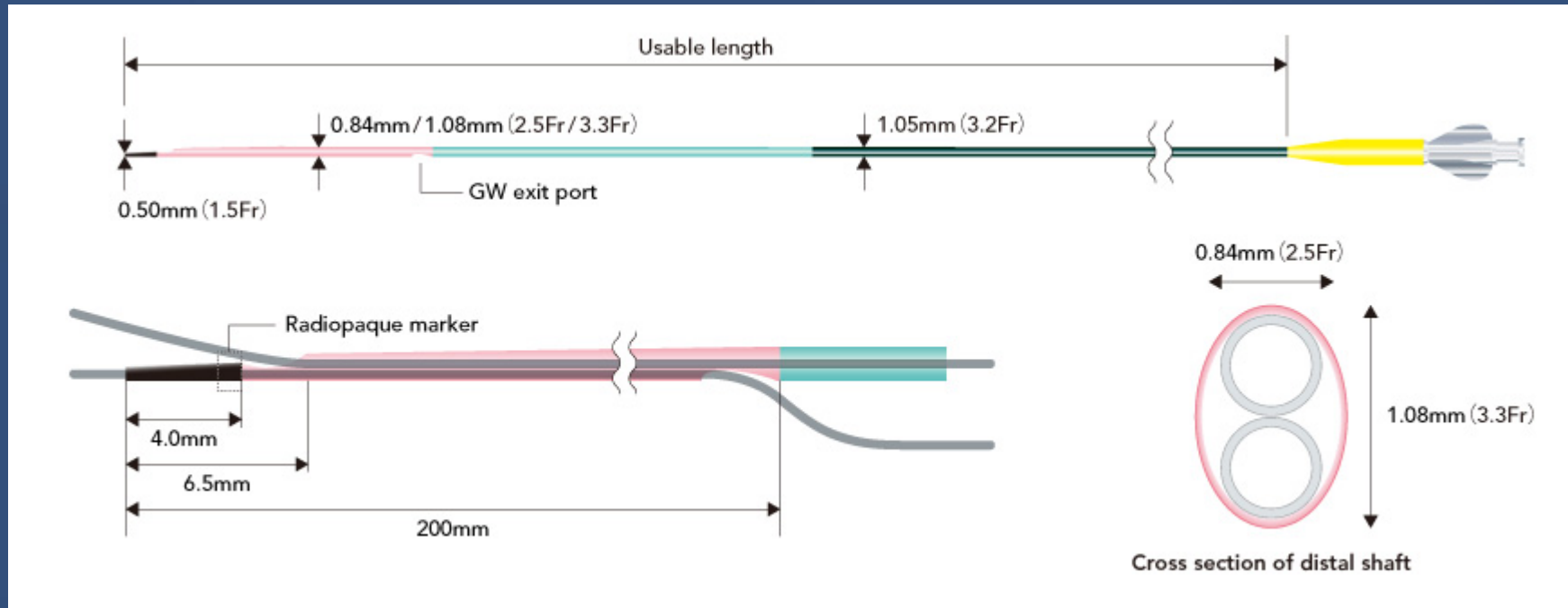

Product	Catalog No.	Outer Diameter			Inner Diameter		Usable Length	Recommended Guide Wire	Hydrophilic Coating Length
		Tip	Distal Shaft	Proximal Shaft	Tip	Shaft			
ASAHI SASUKE	SA145-33N	0.50mm (1.5Fr)	0.84mm / 1.08mm (2.5Fr / 3.3Fr)	1.05mm (3.2Fr)	0.40mm (0.016inch)	0.43mm (0.017inch)	145cm	0.36mm (0.014inch)	38cm

CRUSADE R

□ Distal Shaft

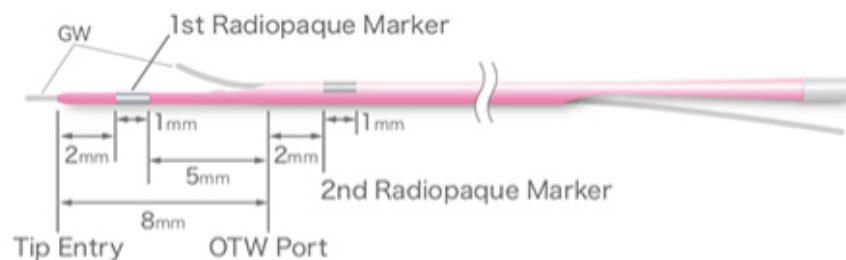

□ Overview of the Catheter

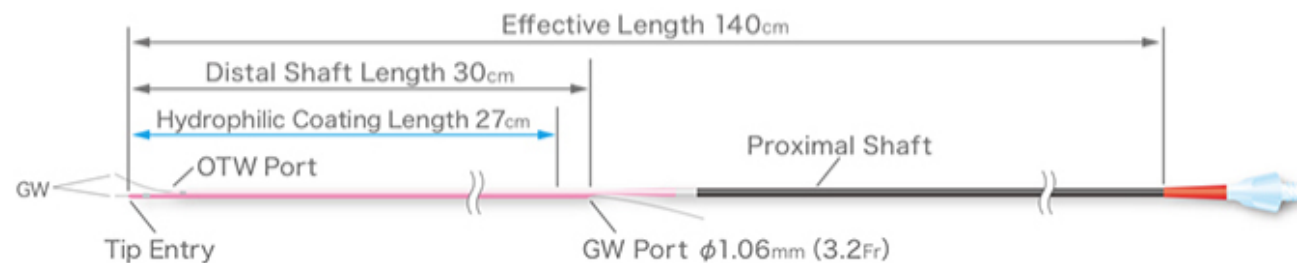

Catalogue Number	Outer Diameter			Inner Diameter		Effective Length	Hydrophilic Coating Length	Compatible Maximum GW Outer Diameter
	Tip Entry	Distal Shaft	Proximal Shaft	Distal Shaft	Proximal Shaft			
CR1414140SD	1.4Fr(0.45mm)	2.9Fr (0.96mm)	3.2Fr(1.06mm)	0.0165" (0.42mm)	0.0177" (0.45mm)	140cm	27cm	0.014" (0.36mm)

TERUMO's Progreat

2.2 Fr. <Super Selective>

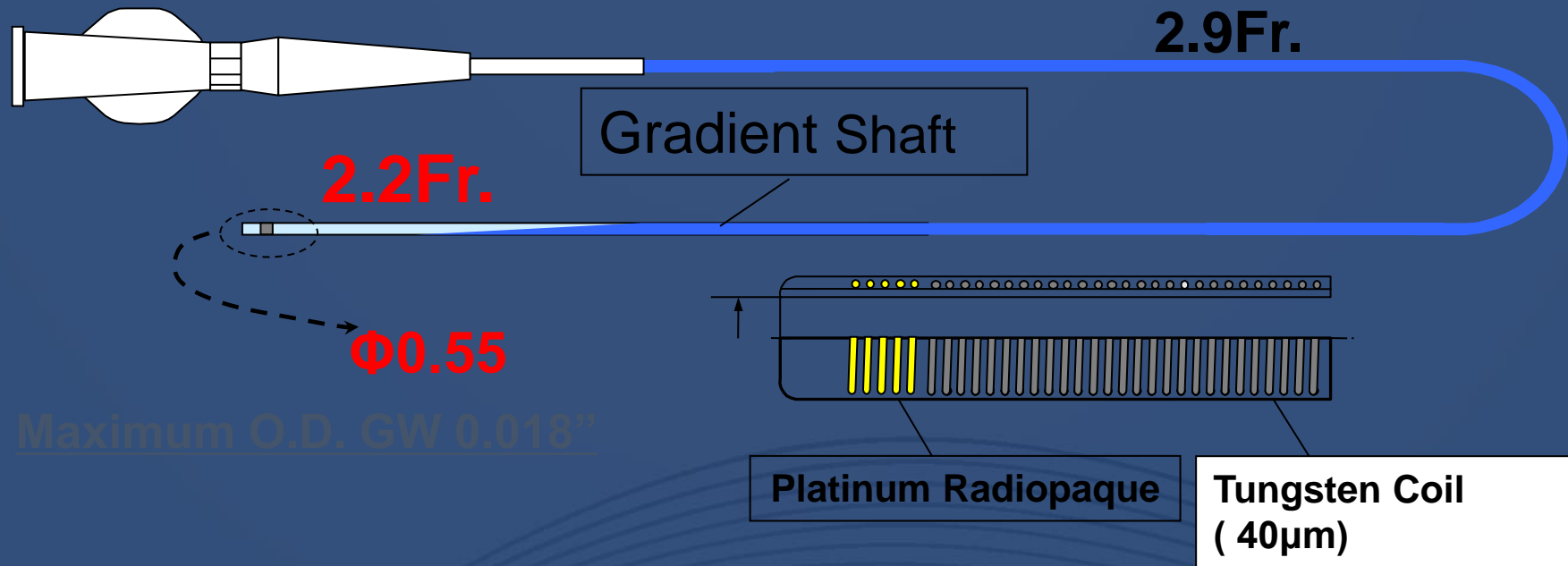

Excellent Trackability
Excellent Handling
Enough Flow rate

TERUMO's Progreat

2.0 Fr. <Super Selective>

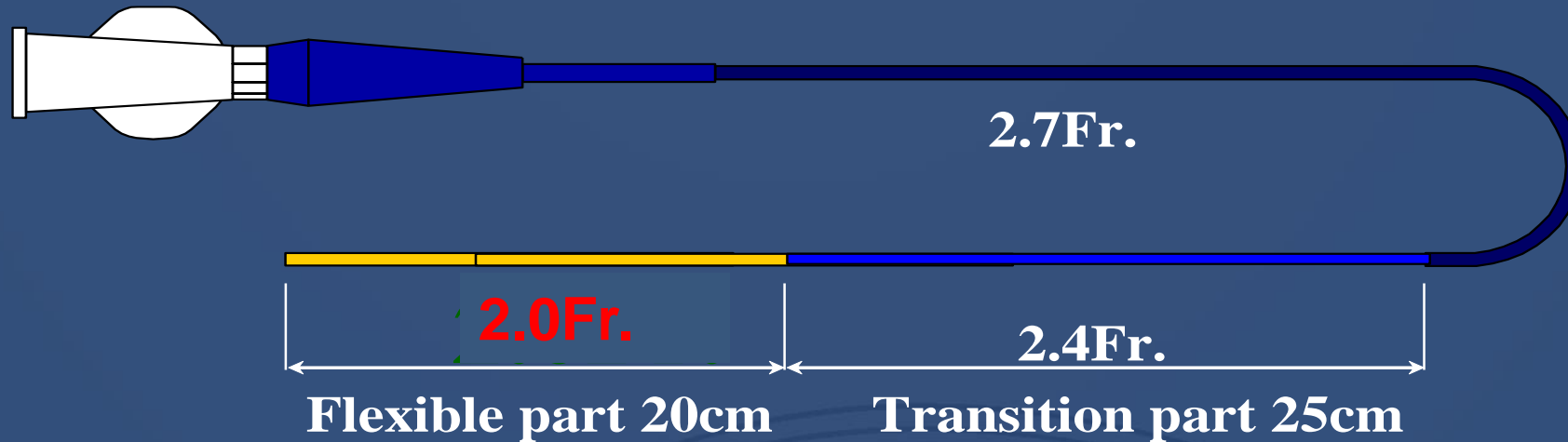

Outer surface : Hydrophilic coating
(Except 60mm from proximal end)

Catheter Size: 2.0 - 2.7Fr. (Distal-Proximal)
Inner diameter: 0.49mm/0.019inch
Length: 100cm,110cm,130cm, 150cm
Max. Injection Pressure: 750psi
Hydrophilic coating

TERUMO's FineCross MG

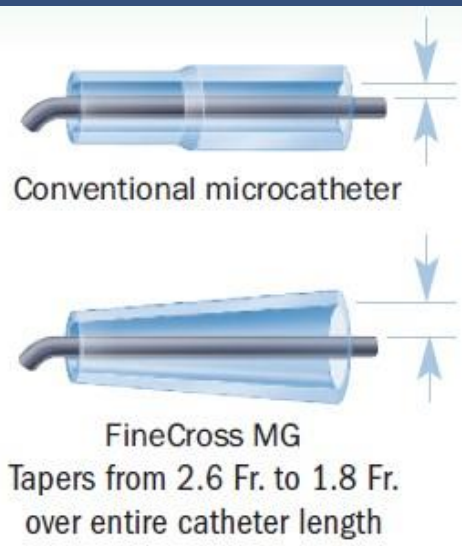
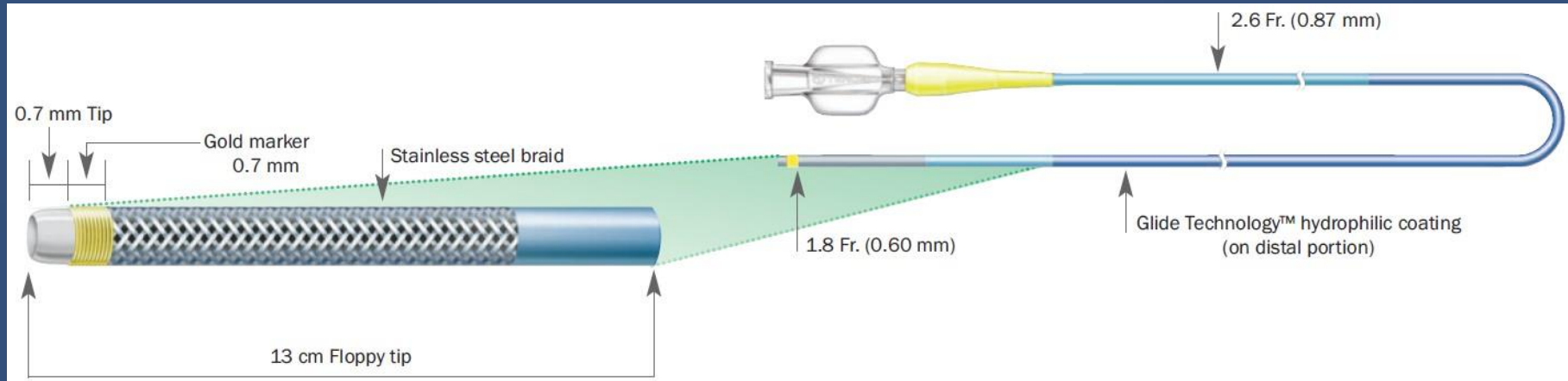

- Stainless steel braid structure
- Hydrophilic coating
- PTFE inner layer
- Tapered diameter
- Catheter length 130 cm / 150 cm
- Integration of superior crossability and optimal guidewire support

ASAHI Tornus

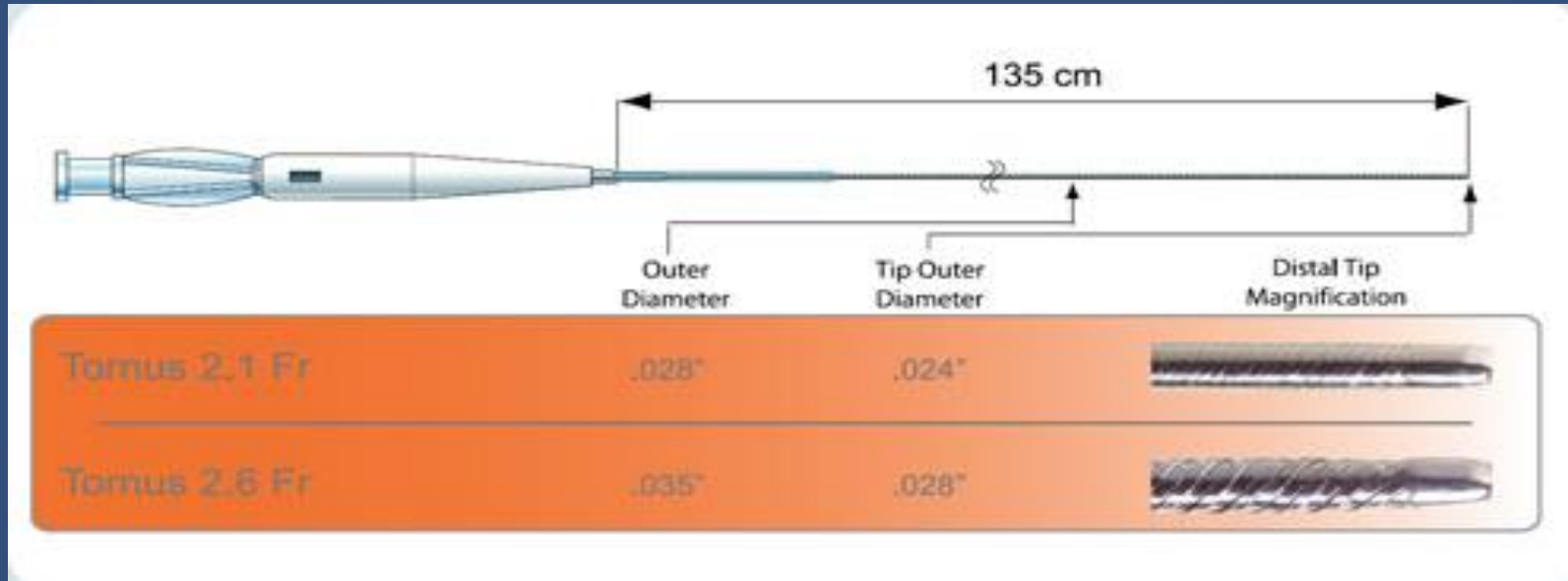

- Braided stainless steel catheter for greater support and pushability
- 1mm distal radiopaque marker for easy visualization of the distal tip
- Tapered threaded tip
- Excellent flexibility for tortuous anatomy

ASAHI Tornus

Structural Feature 1

The metal catheter consists of 8 stainless steel ropes formed in a spiral structure.

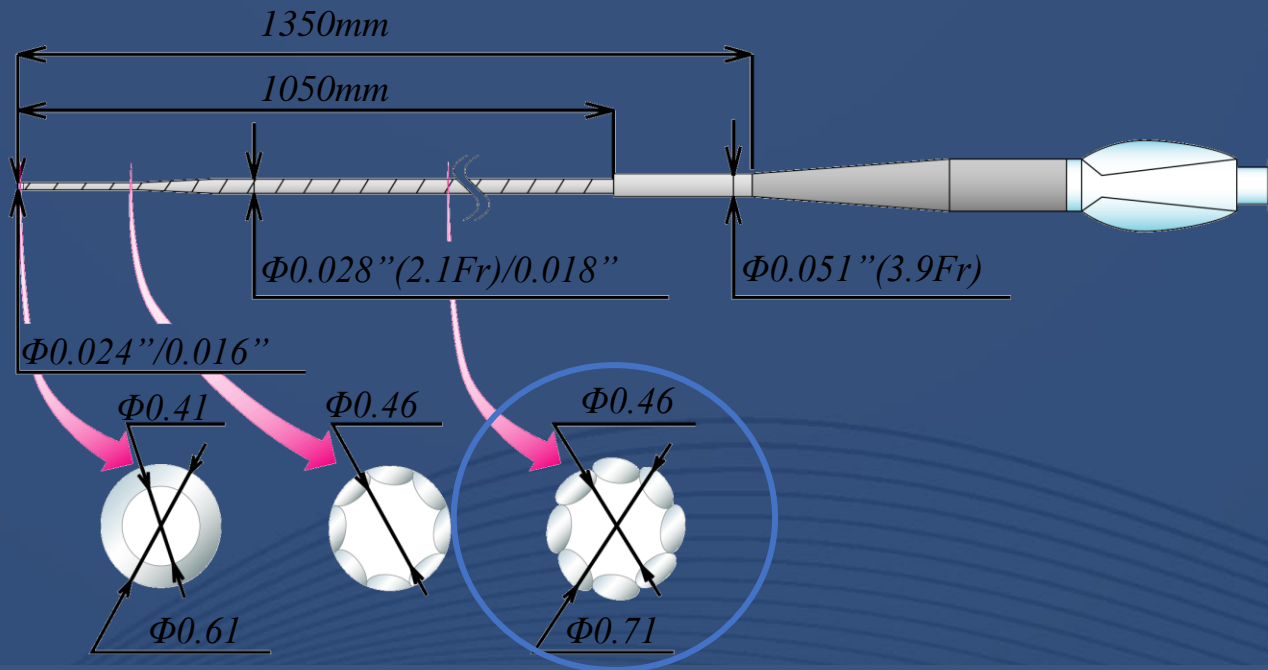

- Combined 8 wires enable high torque performance.
- Spiral structure gives high penetration power by counter-clockwise rotation.
- Helical cut surface provides stronger anchor effects.

ASAHI Tornus

Structural Feature 2

The tapered structure with 150mm from the distal tip.

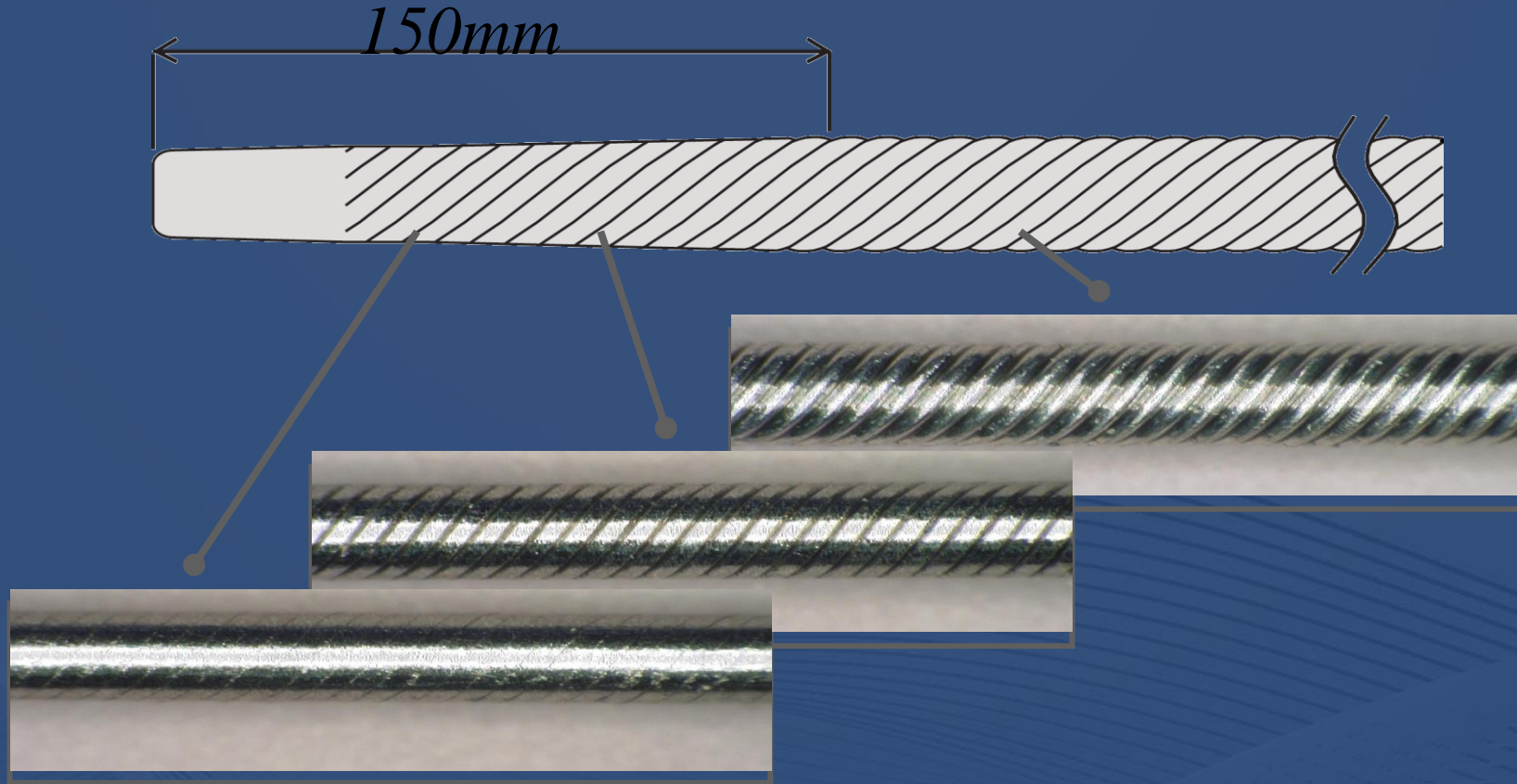

ASAHI Tornus

Available in Two size

Tornus 88Flex

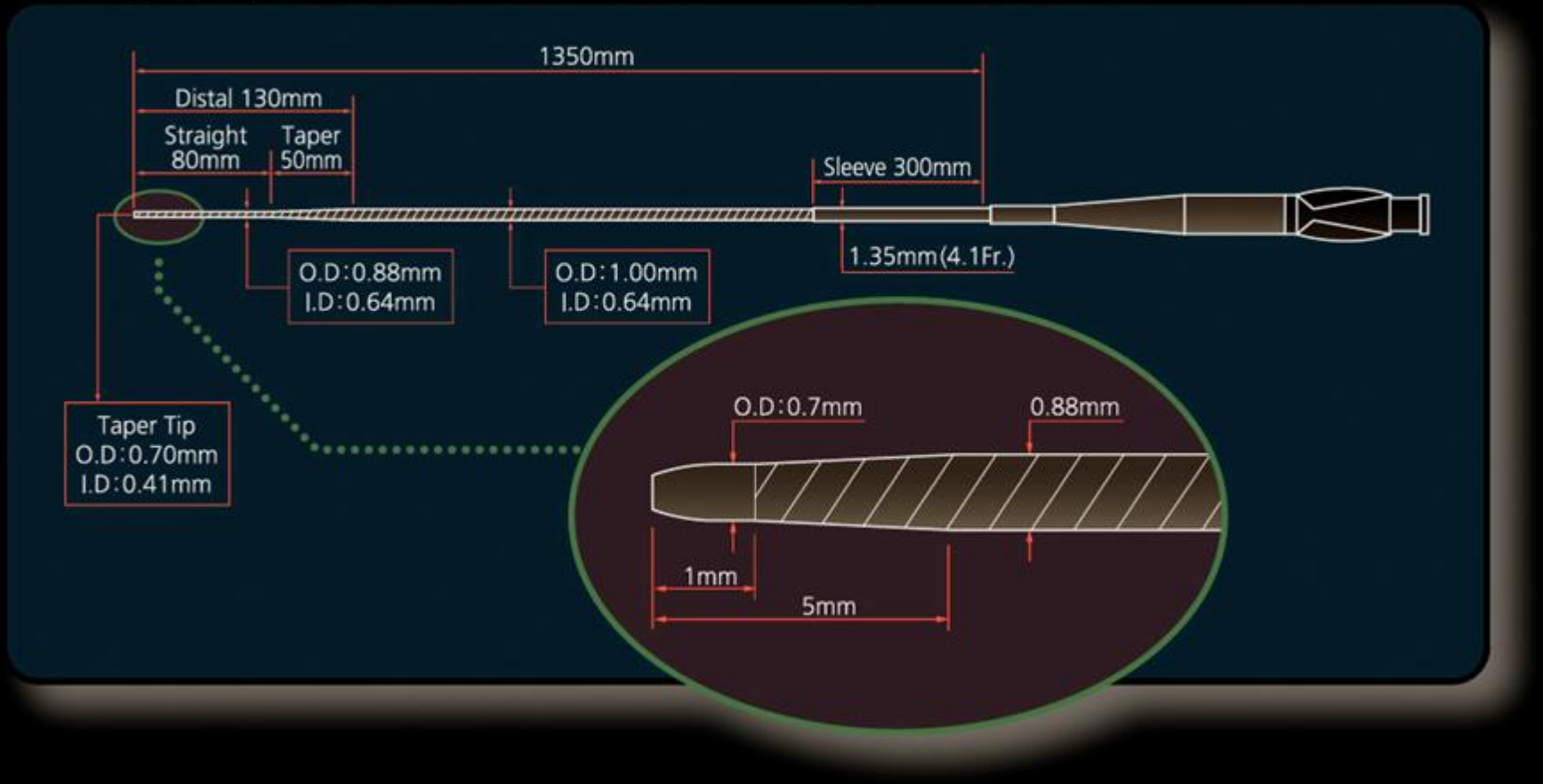

ASAHI Tornus

Magnified Torus Tips

Tornus



Tornus 88Flex



ASAHI Tornus & Tornus 88Flex

■ Tornus



■ Tornus 88Flex

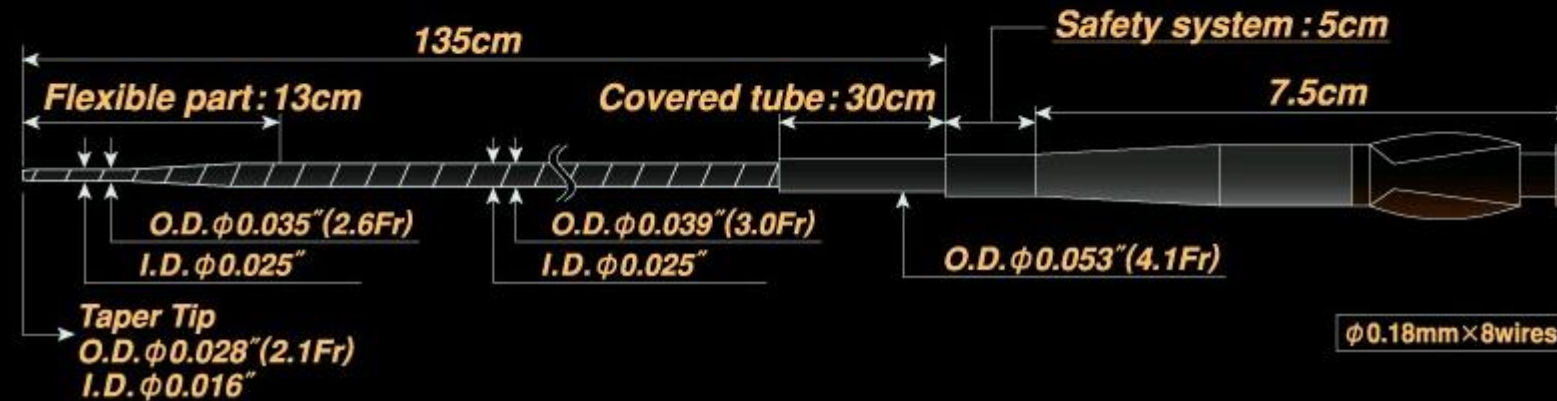

Tornus Pro

Superior lesion crossability & flexible shaft

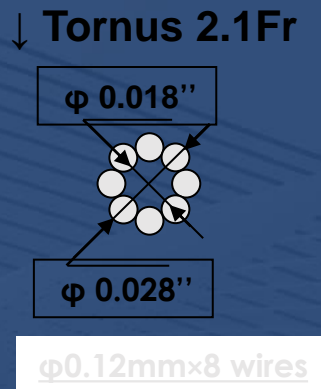
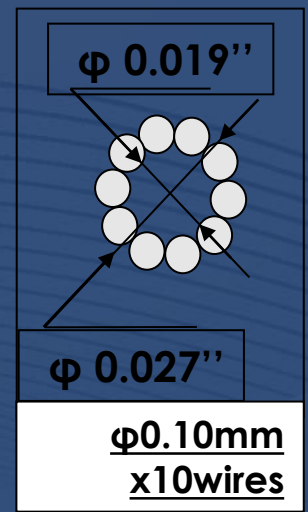
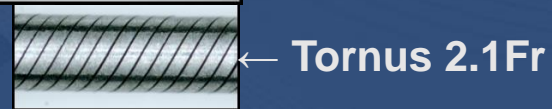
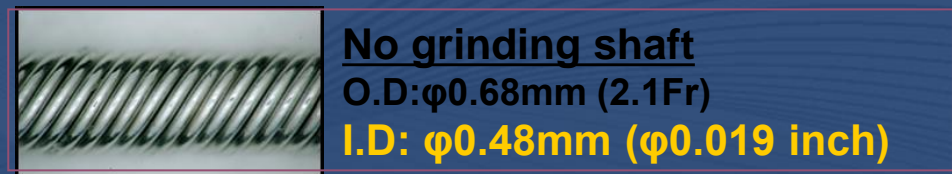
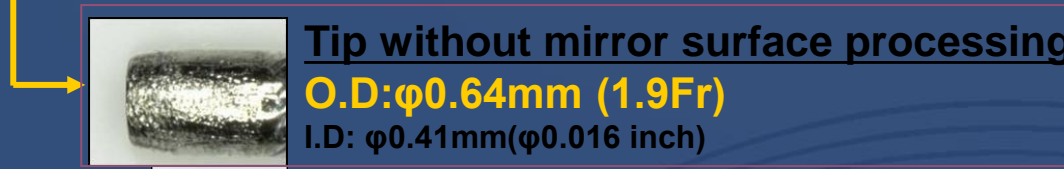
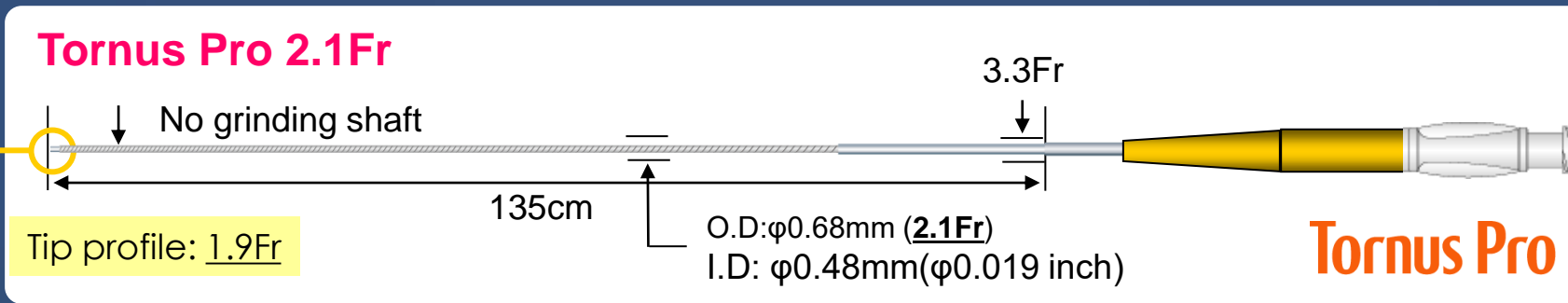

Tornus Pro

Tornus-Pro

$\varphi 0.10\text{mm} \times 10\text{wires}$ as same as Corsair

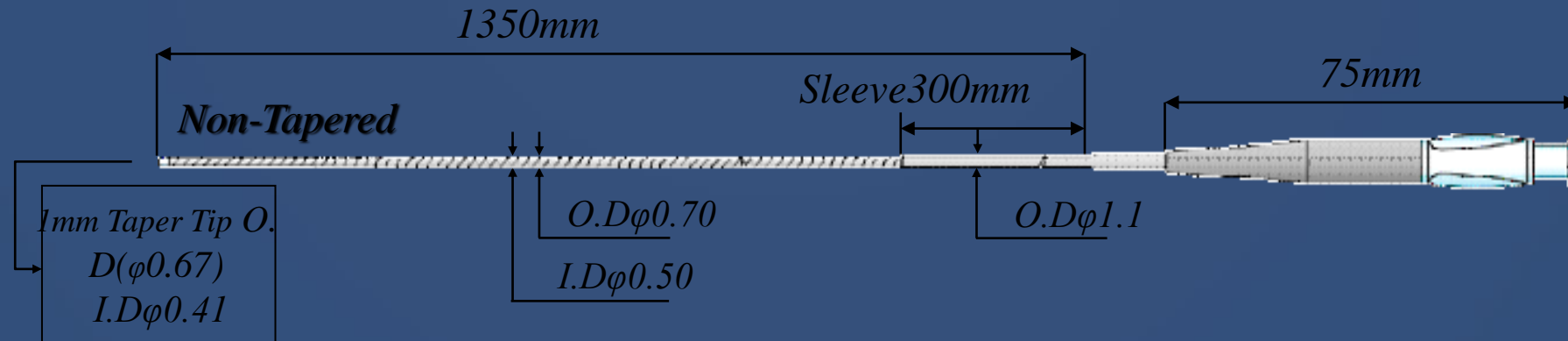

Tornus

$\varphi 0.12\text{mm} \times 8\text{wires}$

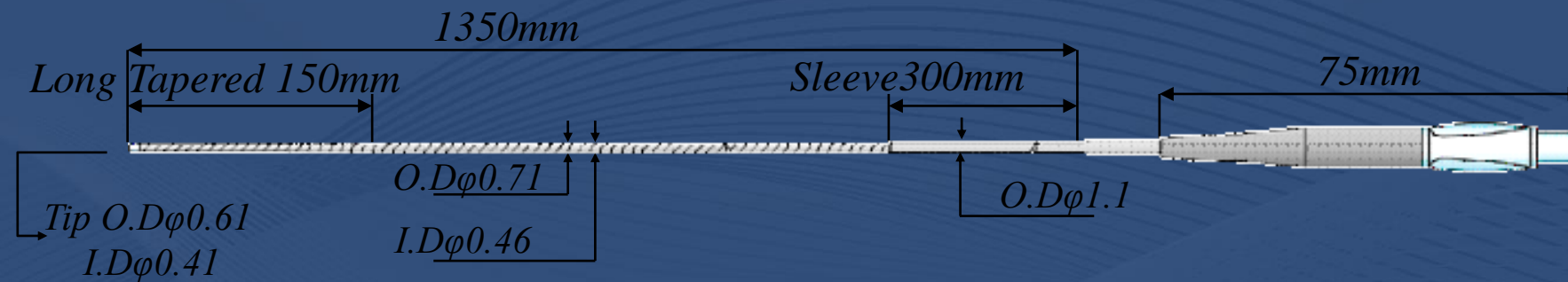

Torus Pro

Features and Benefits

Unpolished shaft

Maximizes the screw effect to pass through tight lesions.



Tornus Pro (Unpolished)

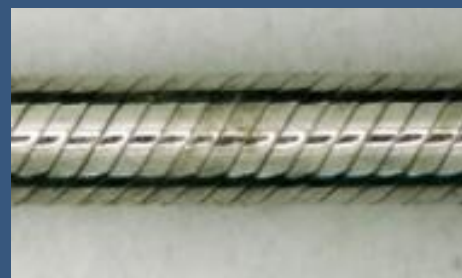

Tornus (Polished)

Torus Pro

Features and Benefits

Non-mirror finishing process on the tip

Deletion of mirror finishing process at the tip prevents from slipping and bouncing back at the tight lesions.

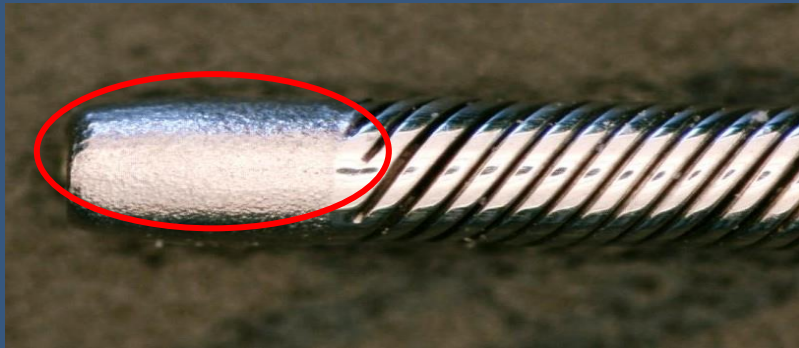

Tornus Pro: Without mirror finishing process



Tornus: With mirror finishing process

Crusade Microcatheter

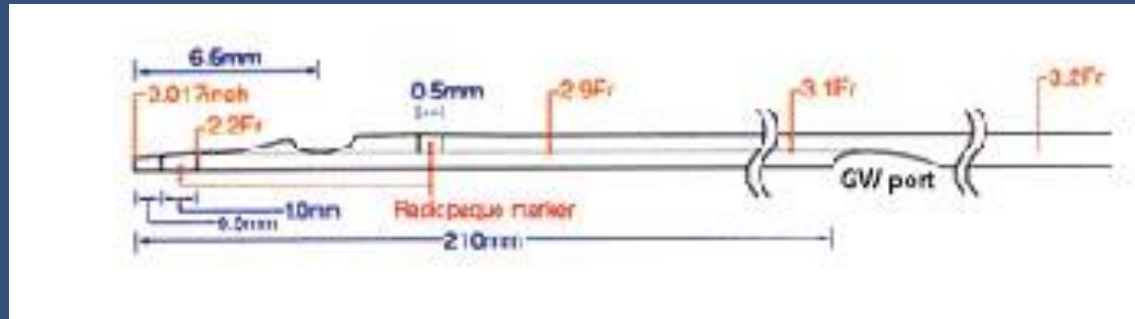

Double Lumen Catheter



- **Superior Shaft Maneuverability**
Optimized configuration and materials enable superior shaft maneuverability. Distal shaft with slender flexible tip
Flexible and strong proximal shaft
- **Superior GW Movement**
A "double layer lumen" allows superior GW movement.
- **Easy to Estimate the Length of Lesion**
Two radiopaque markers on the RX lumen make it easy to estimate the length of the lesion.

Chronic Total Occlusion : Current Techniques

J-CTO SCORE SHEET

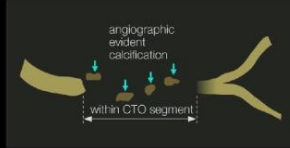
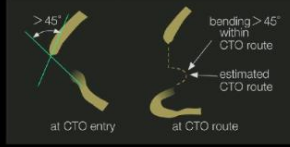
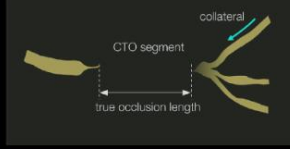
J-CTO SCORE SHEET		Version 1.0	
Variables and definitions			
<p>Tapered</p> 	<p>Blunt</p> 	<p>Entry with any tapered tip or dimple indicating direction of true lumen is categorized as "tapered".</p>	
		<p>Entry shape</p> <input type="checkbox"/> Tapered (0) <input type="checkbox"/> Blunt (1)	
		point	
<p>Calcification</p> 			<p>Regardless of severity, 1 point is assigned if any evident calcification is detected within the CTO segment.</p>
		<p>Calcification</p> <input type="checkbox"/> Absence (0) <input type="checkbox"/> Presence (1)	
		point	
<p>Bending >45degrees</p> 			<p>One point is assigned if bending > 45 degrees is detected within the CTO segment. Any tortuosity separated from the CTO segment is excluded from this assessment.</p>
		<p>Bending >45°</p> <input type="checkbox"/> Absence (0) <input type="checkbox"/> Presence (1)	
		point	
<p>Occlusion length</p> 			<p>Using good collateral images, try to measure "true" distance of occlusion, which tends to be shorter than the first impression.</p>
		<p>Occl.Length</p> <input type="checkbox"/> <20mm (0) <input type="checkbox"/> ≥20mm (1)	
		point	
<p>Re-try lesion</p> <p>Is this Re-try (2nd attempt) lesion ? (previously attempted but failed)</p>			<p>Re-try lesion</p> <input type="checkbox"/> No (0) <input type="checkbox"/> Yes (1)
		point	
<p>Category of difficulty (total point)</p> <input type="checkbox"/> easy (0) <input type="checkbox"/> Intermediate (1) <input type="checkbox"/> difficult (2) <input type="checkbox"/> very difficult (≥3)		<p>Total</p> <div style="background-color: #ccc; width: 30px; height: 20px; display: inline-block;"></div> points	

Asia Pacific CTO club new algorithm

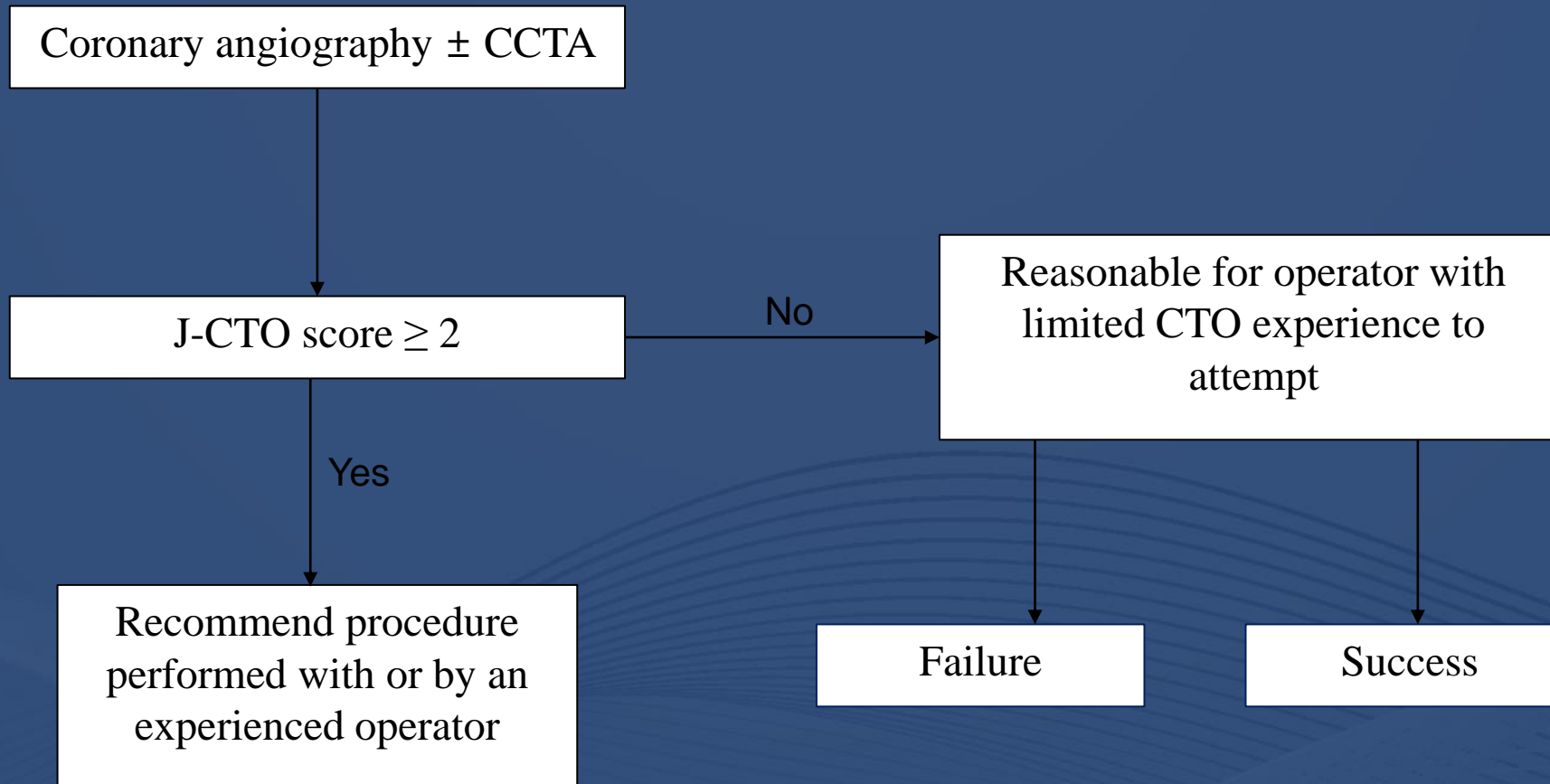

Algorithm for CTO crossing

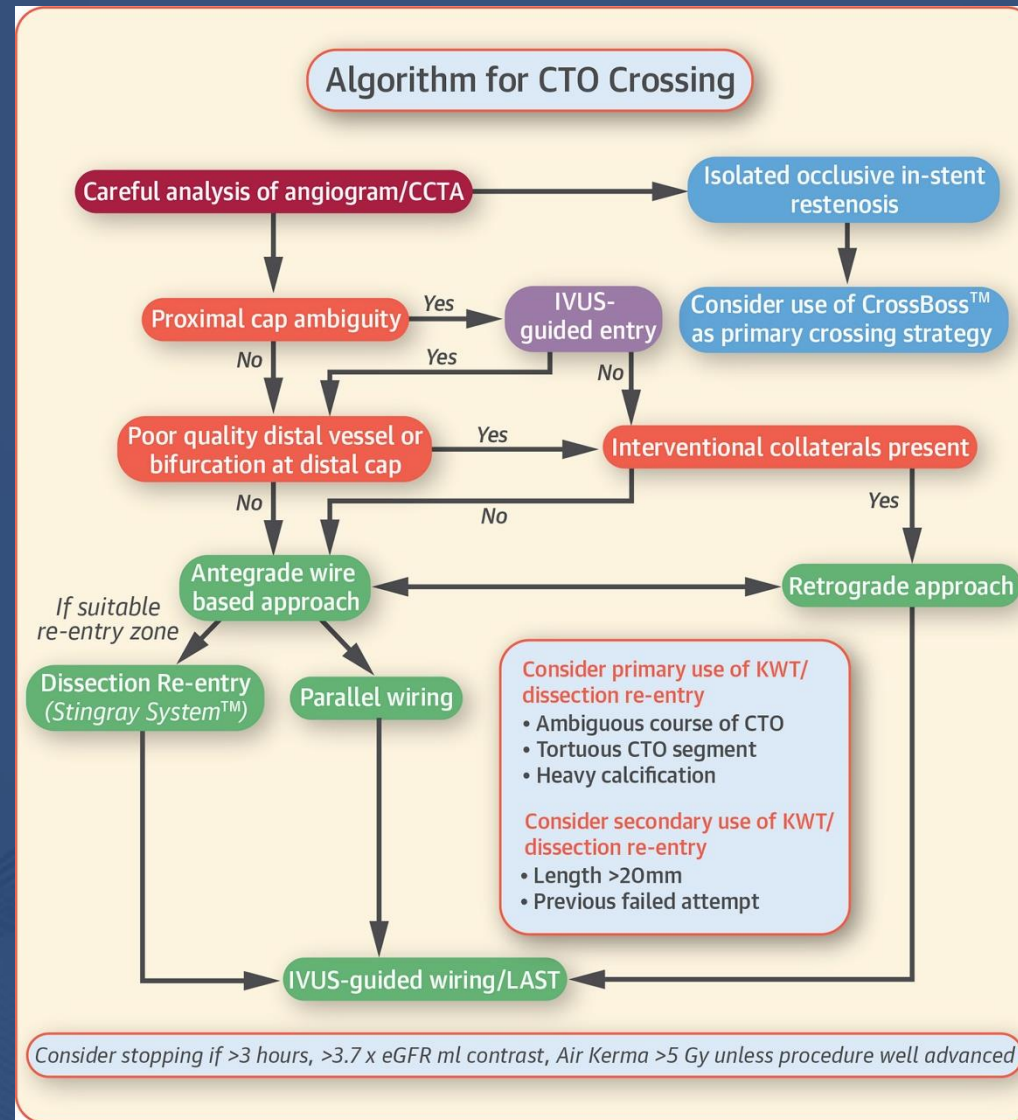

Complexity of CTO

	Level of PCI complexity	
	Easy	Complex
Age of CTO	< 6 months	> 12 months
Occlusion length	< 20 mm	> 20 mm
Calcification at CTO	None/moderate	Severe
Occlusion Stump	tapered	Blunt or absent
Tortuosity at CTO	None/minimal	Moderate/severe
Visibility of the distal vessel	Good/excellent	Poor
Tortuosity proximal to CTO	Minimal/moderate	Severe
Ostial location	Yes	No
CTO at proximal/mid LCX	No	Yes
Expected guiding catheter support	Good	Poor
Renal insufficiency	Yes	No
Previous attempts	No	Yes
Expected patient tolerance	Good	Poor

Patient Selection and Predictors of Success

Angiographic Lesion Morphology

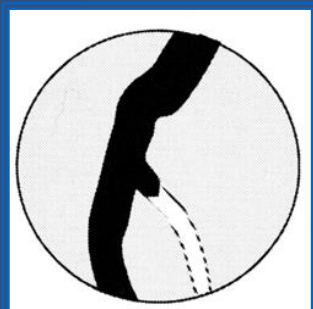

Tapered Stump

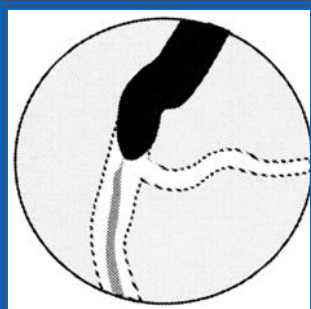

Functional occlusion

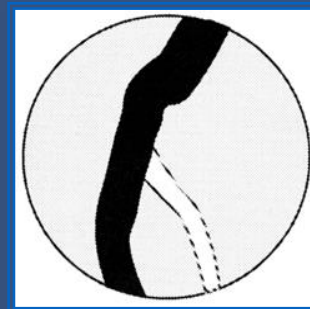

Stump absent

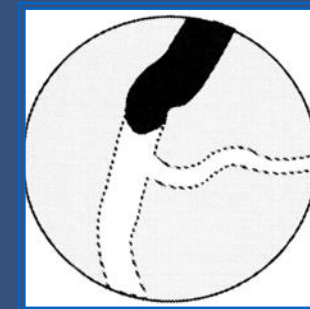

Total occlusion

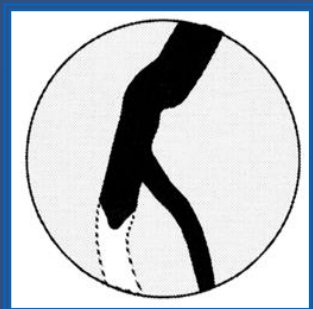

Pre or Post-branch occlusion
collaterals absent

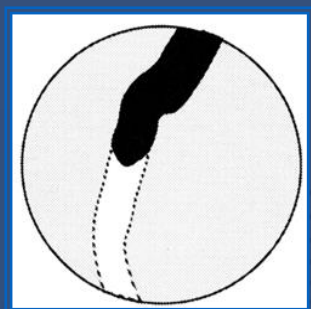

Bridging

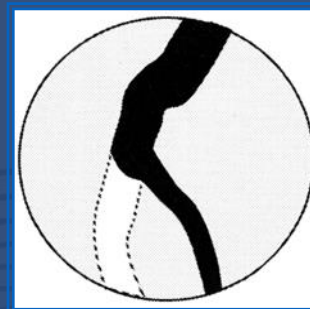

Occlusion at side-branch

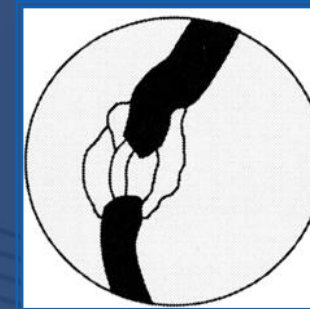

Bridging
collaterals present

Favor Procedural Success



Does Not Favor Procedural Success

Where should we go?

too many ways !

confused

Retrograde knuckle wire technique

Kissing wire technique

Parallel wire technique

Micro-channel tracking

See-saw wire technique

STAR technique

Penetration

Reverse CART

Drilling

IVUS guided wire technique

CART technique

Roadmap to CTOs

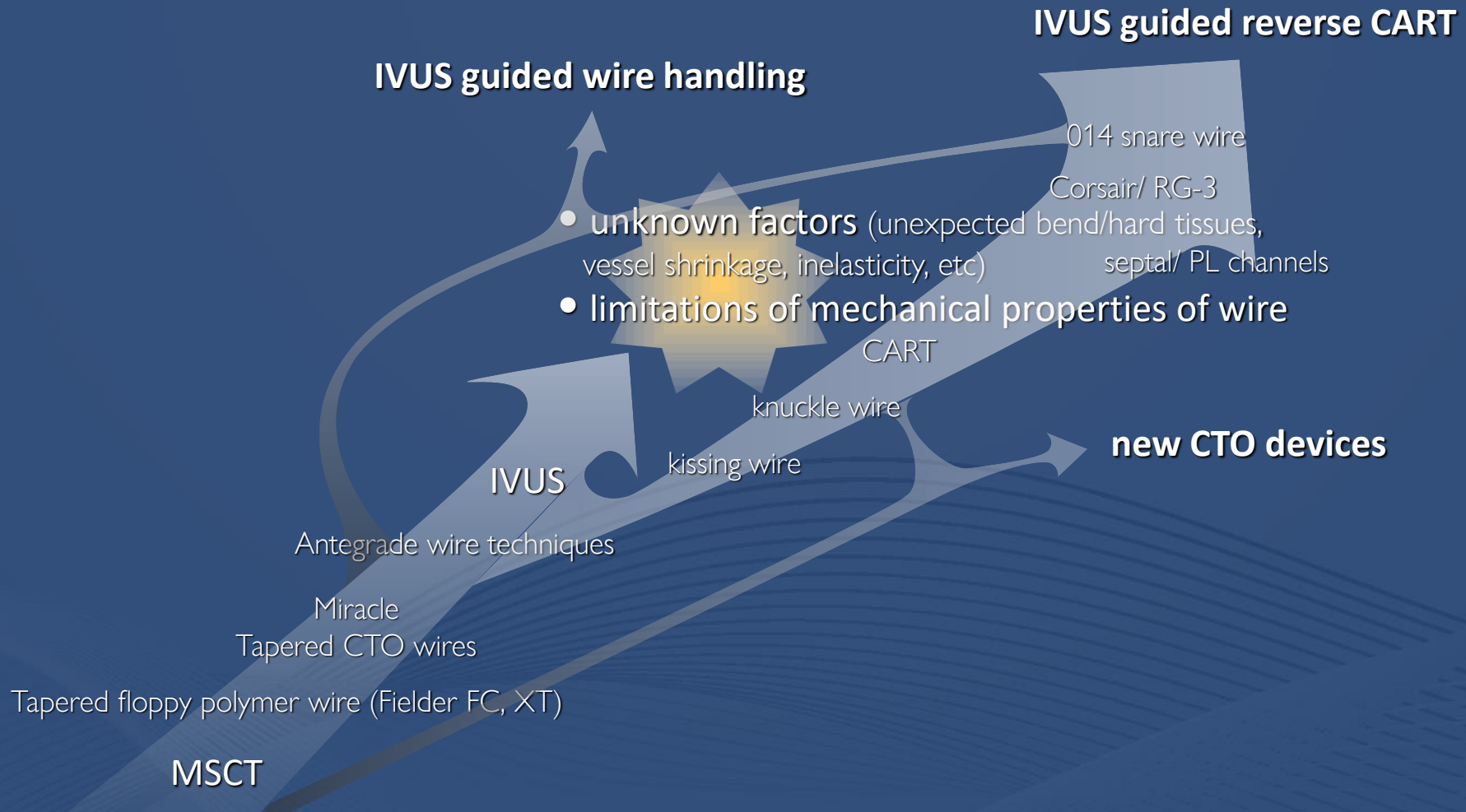

New Devices

The CrossBoss™ CTO Catheter Design

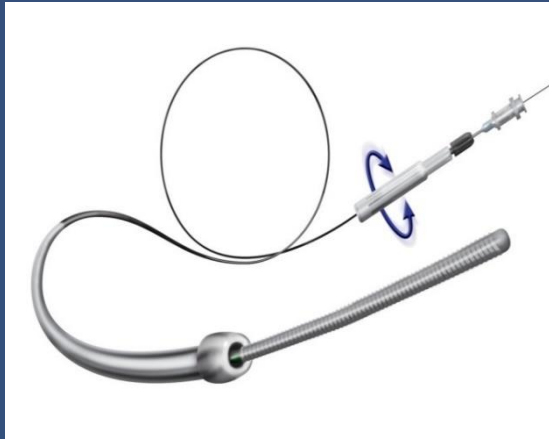

The Stingray™ CTO Re-entry System Design

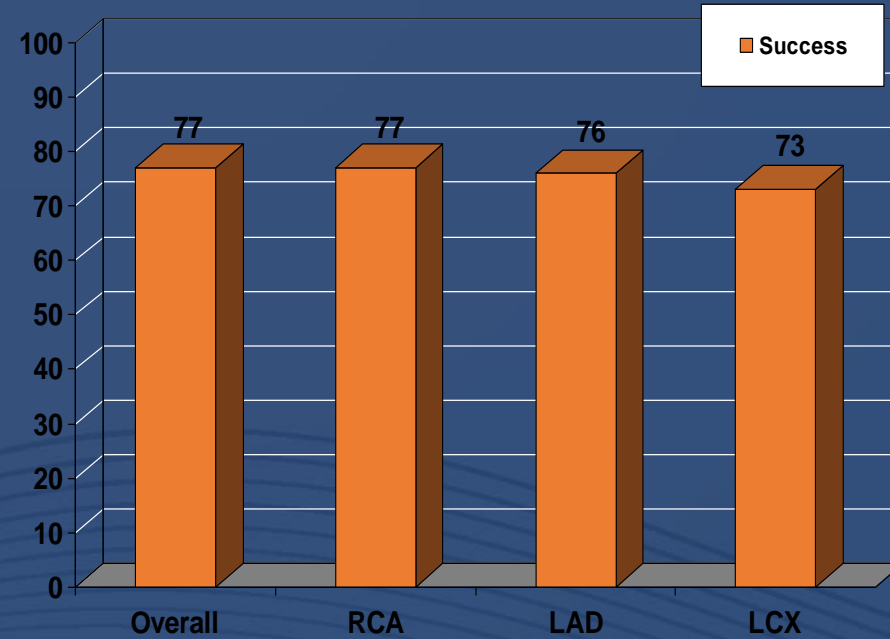
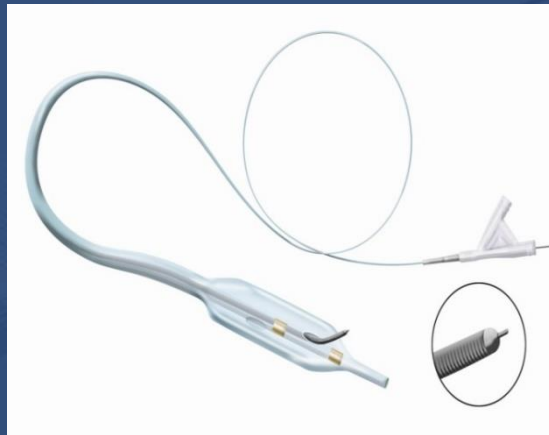

The Hybrid Algorithm for CTO PCI

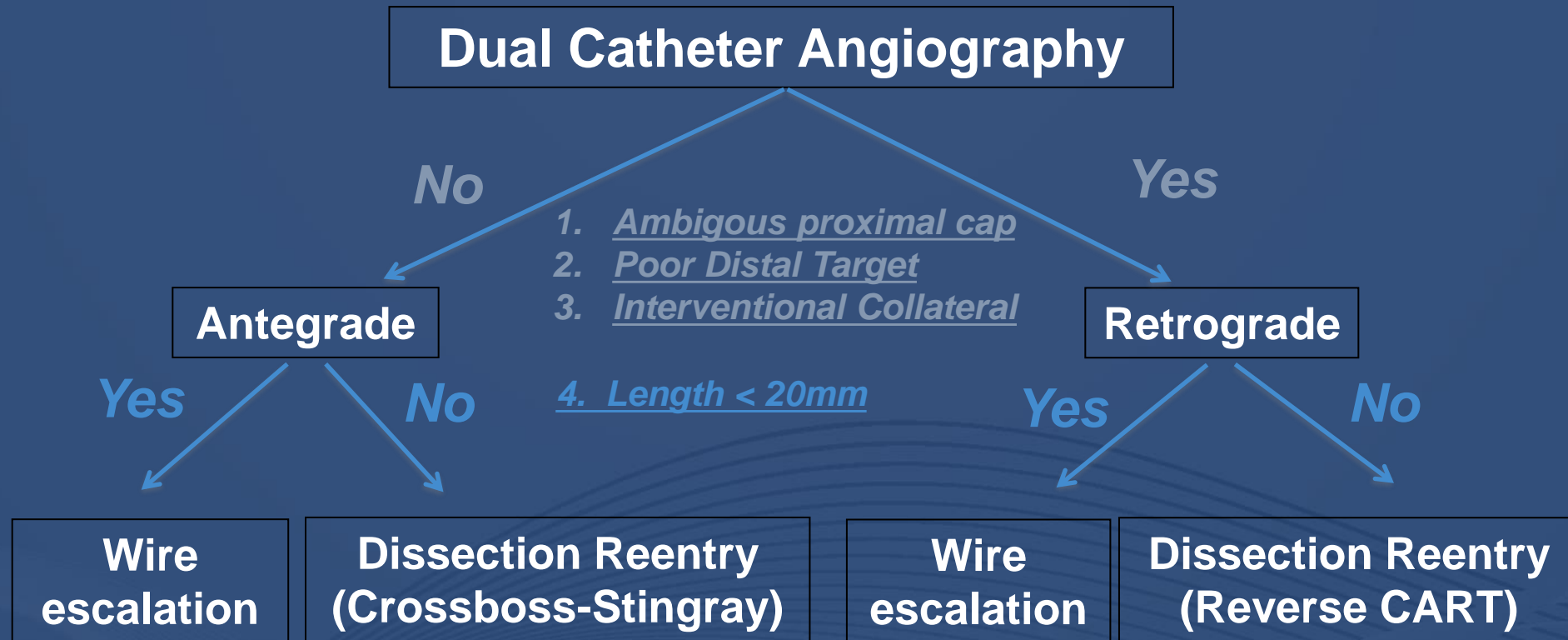

Antegrade Approach

Guidewire Operator Techniques

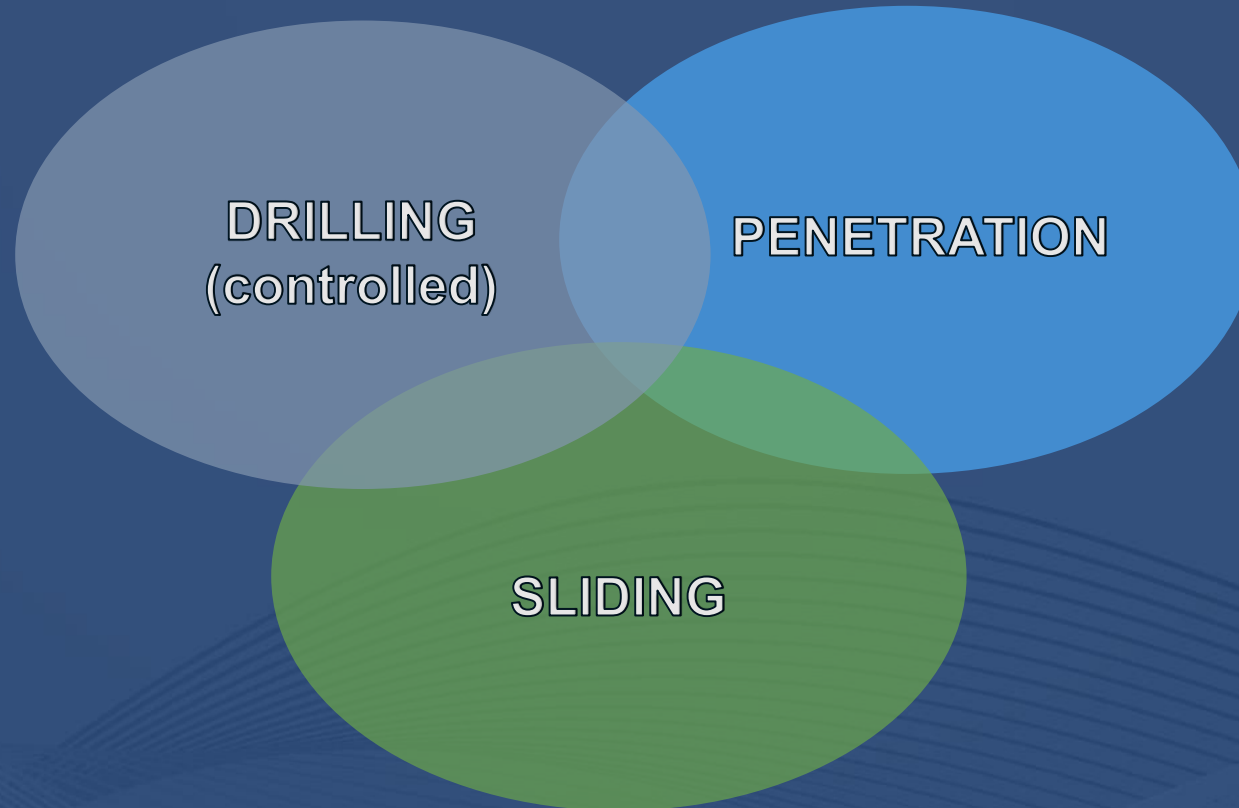

Simple Technique

Conventional technique *Drilling strategy*

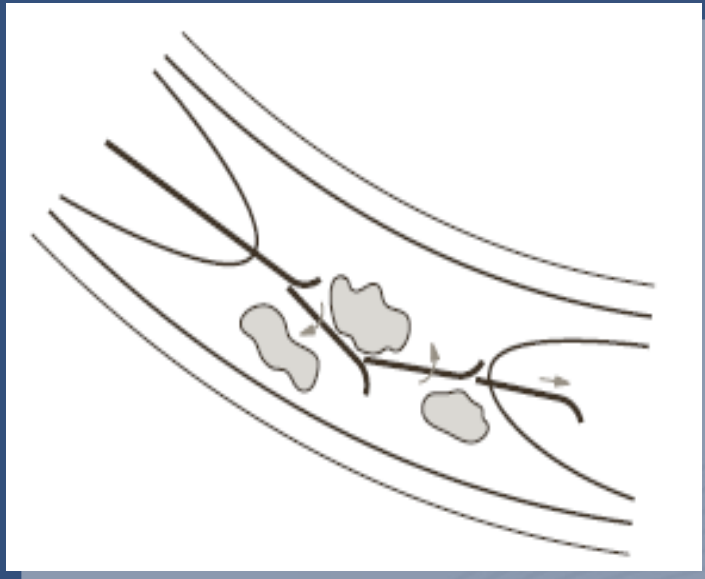

When the tip of a wire encounters hard tissue, the wire is advanced and retracted repeatedly to find soft part of CTO and is pushed through it

New technique *Penetrating strategy*

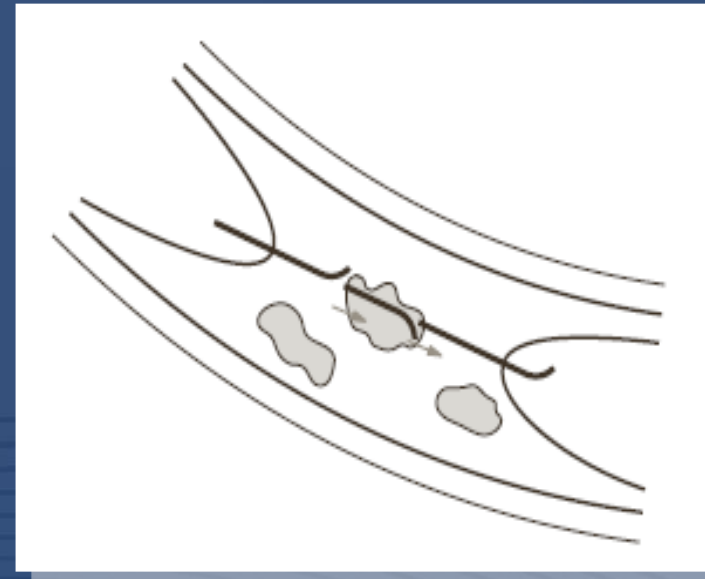

Stiff wire is used from the start of the procedure and advanced in the planned direction through hard tissue

Ochiai M et al, Ital Heart J 2005;6:489-493

Antegrade CTO Wiring Techniques

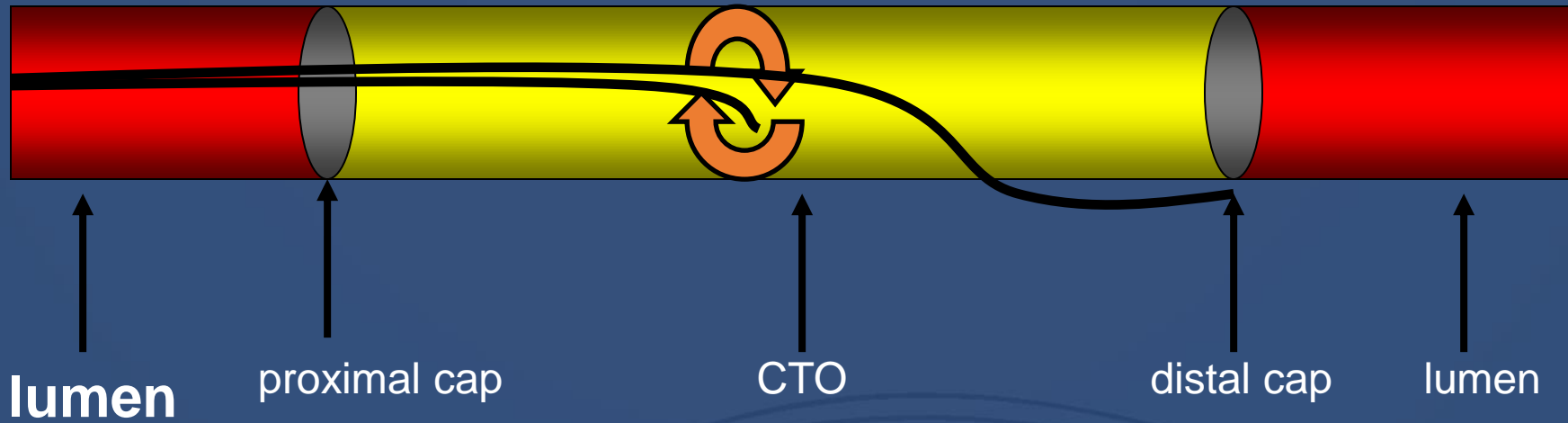

Uncontrolled drilling
FAILURE!

Antegrade CTO Wiring Techniques

Controlled Drilling (90 degree arc)

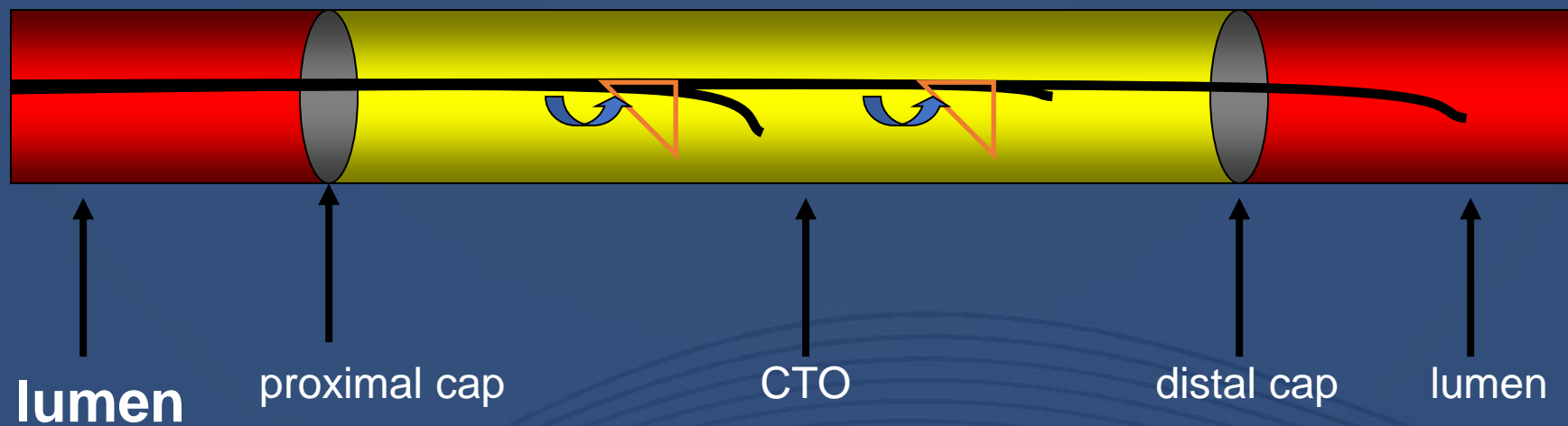

Antegrade CTO Wiring Techniques

Penetration Techniques

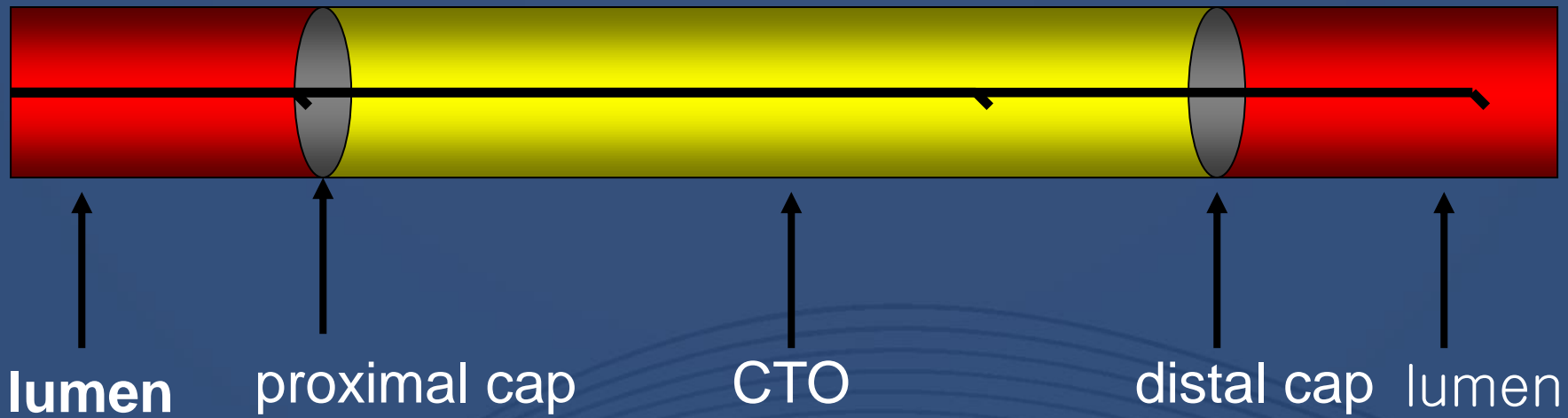

Antegrade CTO Wiring Techniques

Sliding Techniques

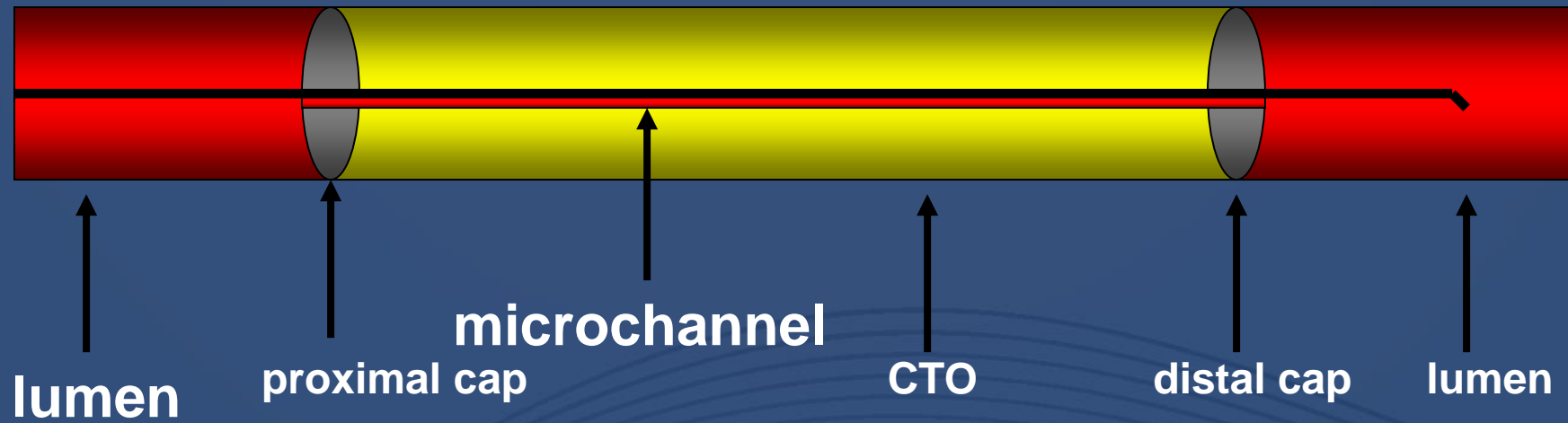

Simple Technique

*Conventional
technique*

Drilling strategy

Intermediate GW

↓ *Not cross*

Standard GW

↓ *Not cross*

Stiffer GW (0.014 inch)

↓ *Not cross*

Other stiffer GWs

↓ *Not cross*

Stiff Tapered GW

New technique

Penetrating strategy

Intermediate GW



Not cross

*Stiff Tapered +/-
Hydrophilic
coating*

Deflecting Tip Wire

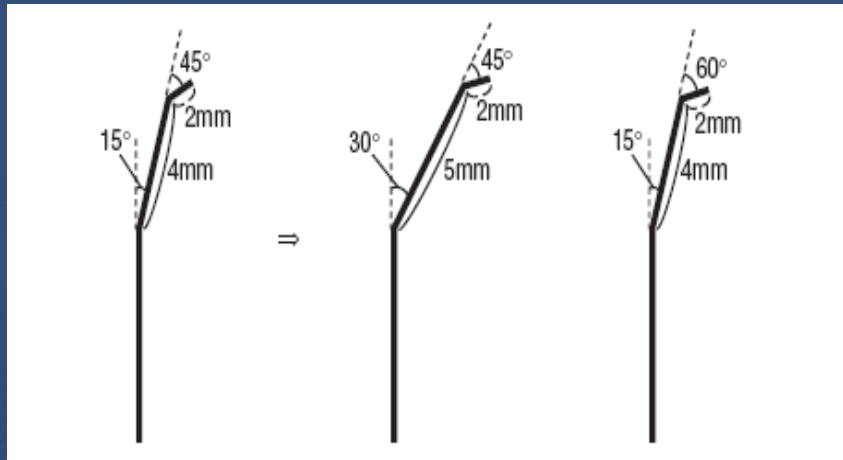
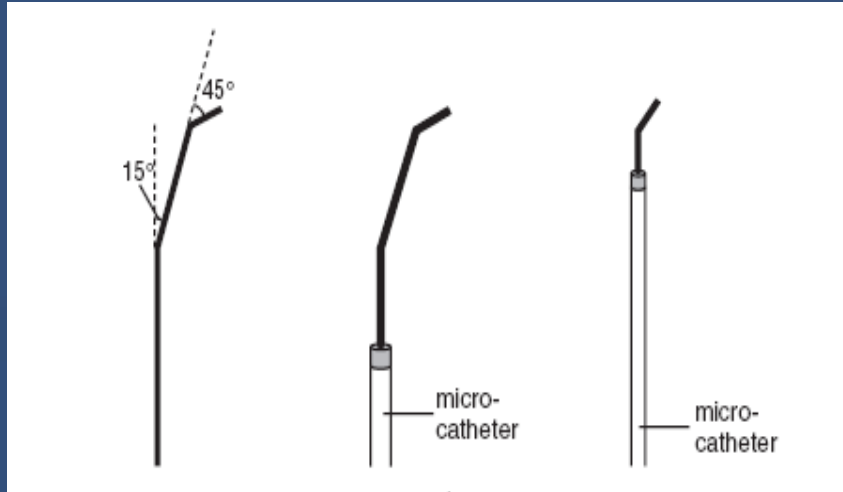

- Double-bend method. In addition to the first small curve (2 mm) made at the tip of a wire to find a true lumen, a larger shallow curve (4-5 mm) is added to cope with the curvature of the blood vessel. It is possible to use or extend the second curve at the tip of a microcatheter.
- When the parallel wire technique is used, it is possible to advance the second wire along a different channel by making the first or second curve different from that of the first wire

CTO Guidewires – Tip Shaping

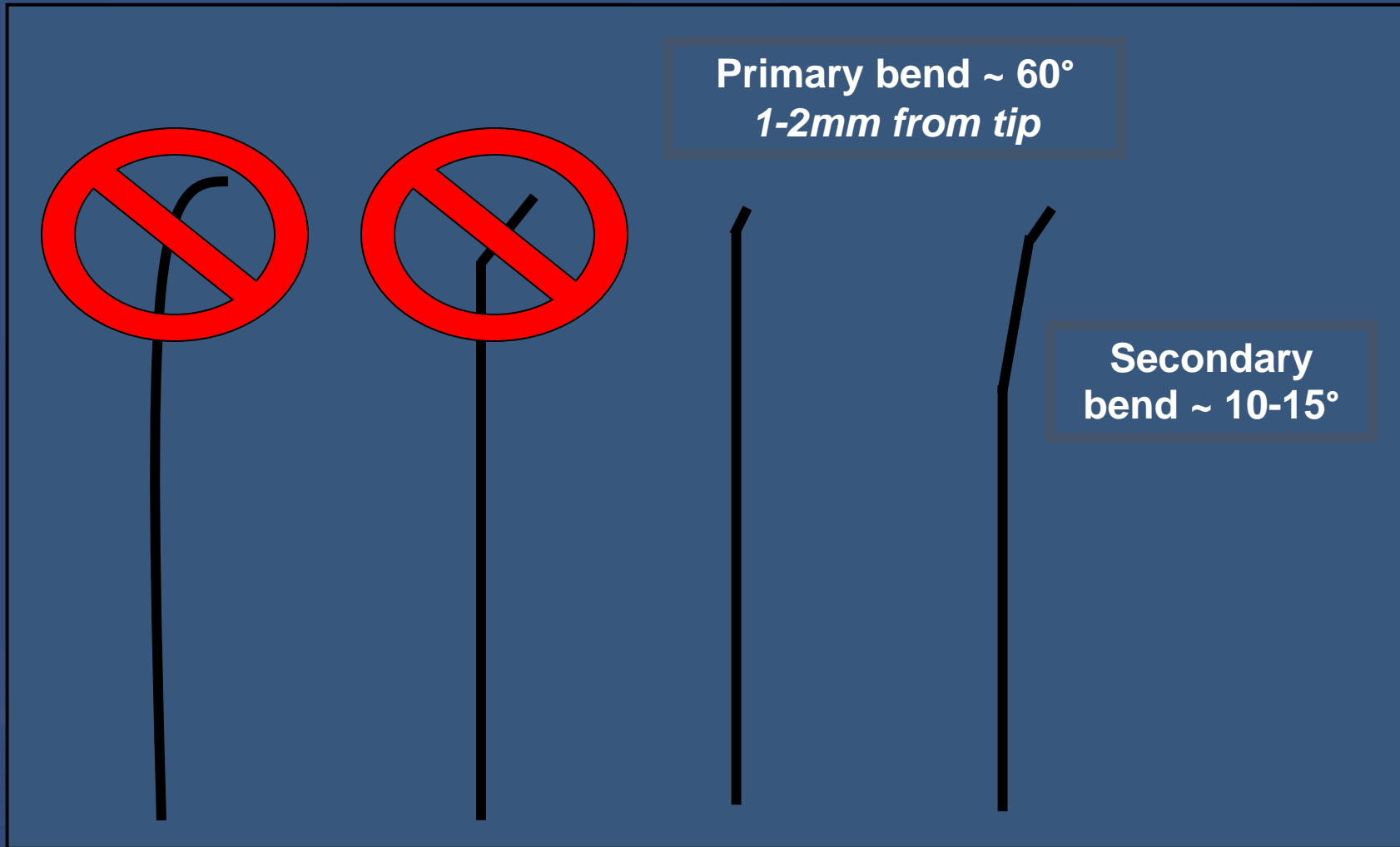

Antegrade CTO Wiring Techniques

Severe Tortuosity

Miracle 3



Miracle 6, 12



Parallel/See-saw wiring
with support catheters

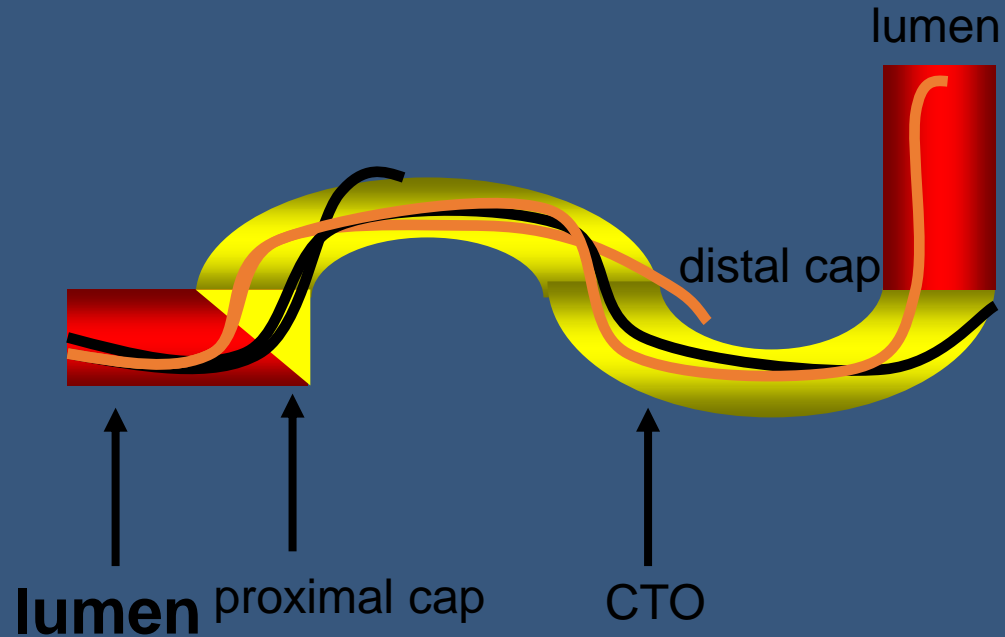

Inner curve less apt to dissect

Deflecting Tip Wire

For penetrating the entry point

For reentering to the
true lumen from the subintima

Creation of Re-entry

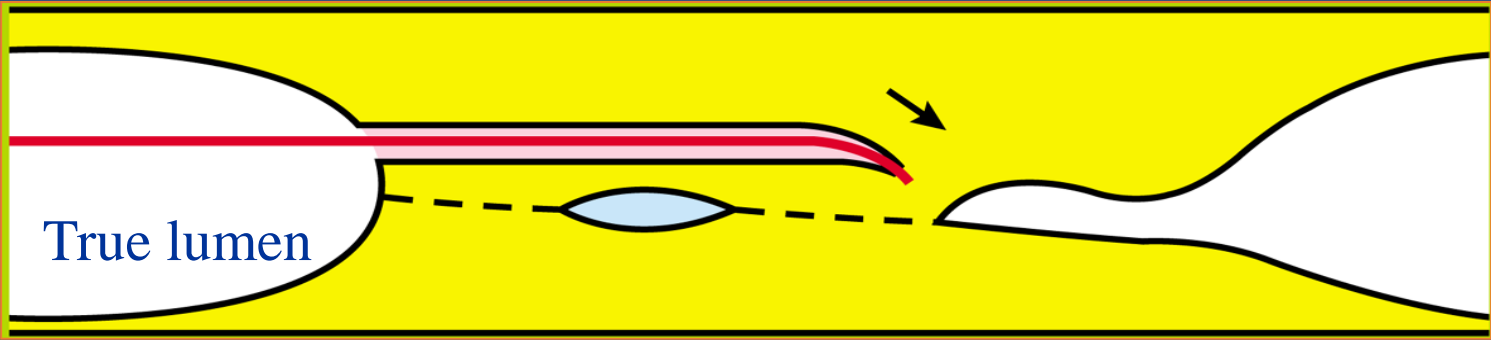

Easy to make re-entry

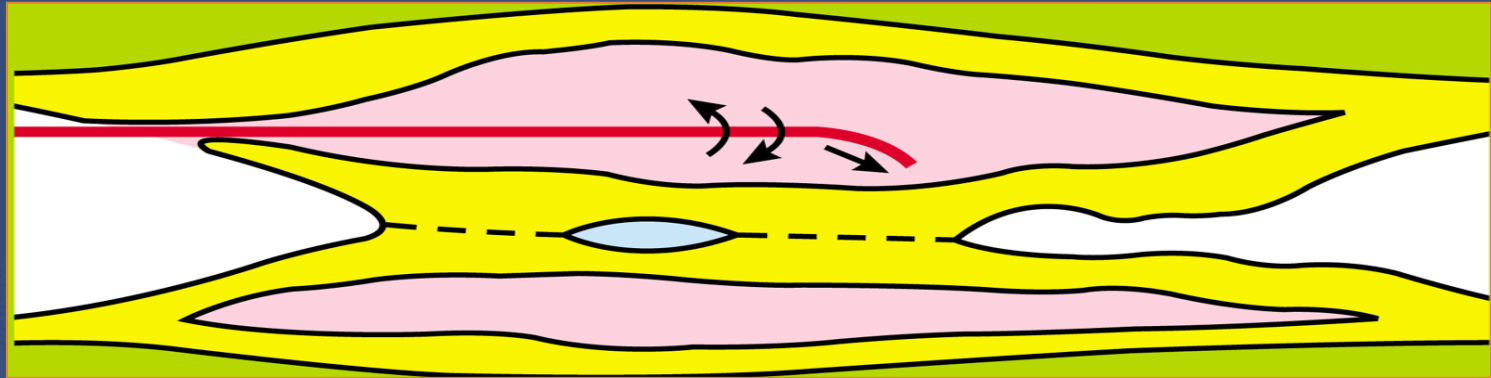

Difficult to make re-entry

Deflecting Tip Wire Case Example

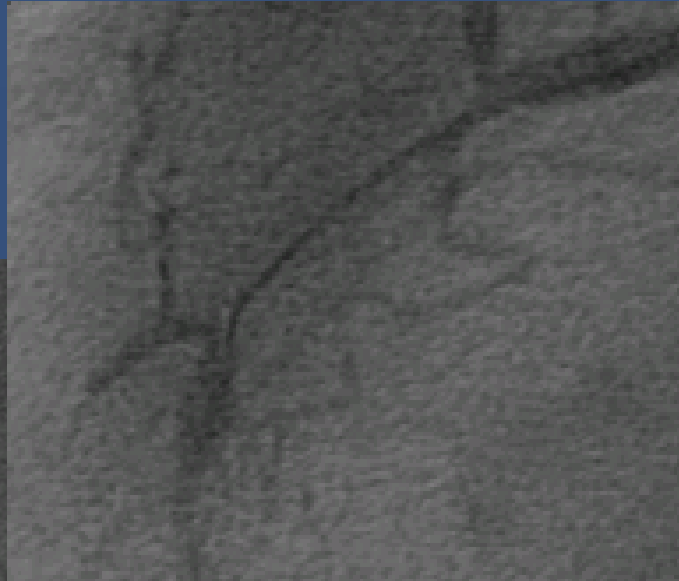
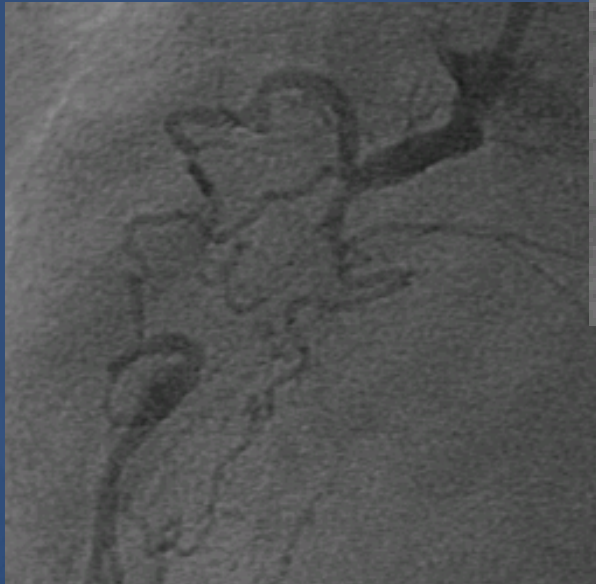

Wire technique for locating another channel

Tip Shape is Key !

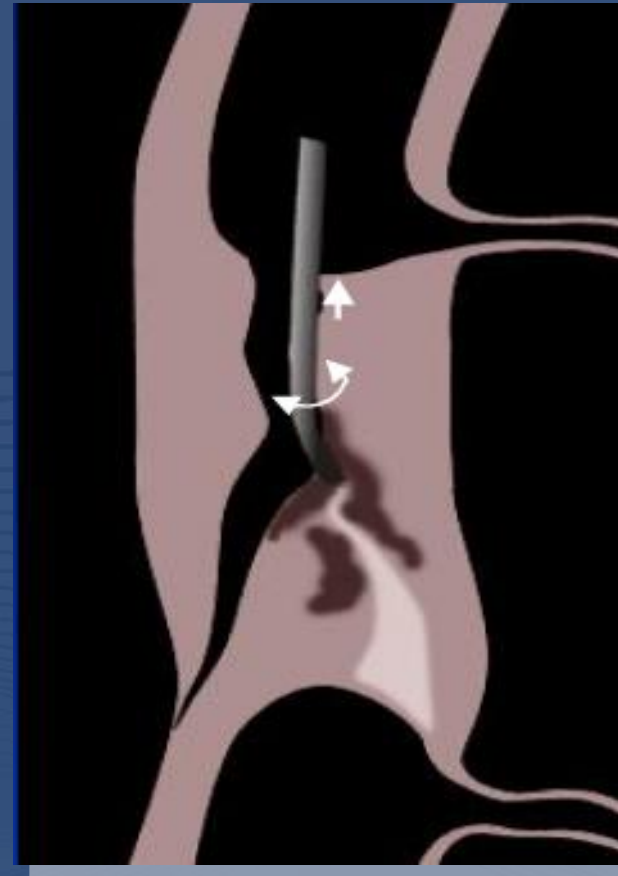
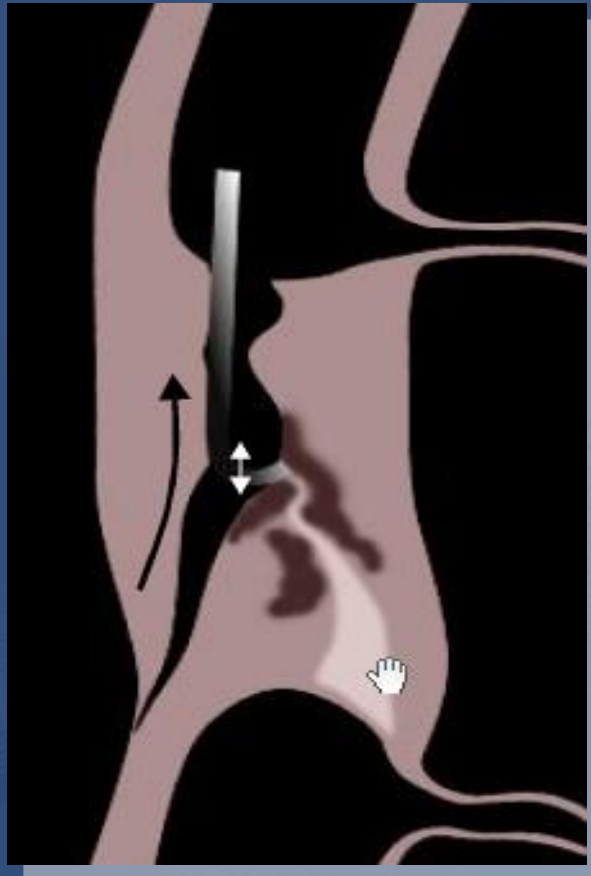

Single wire manipulation

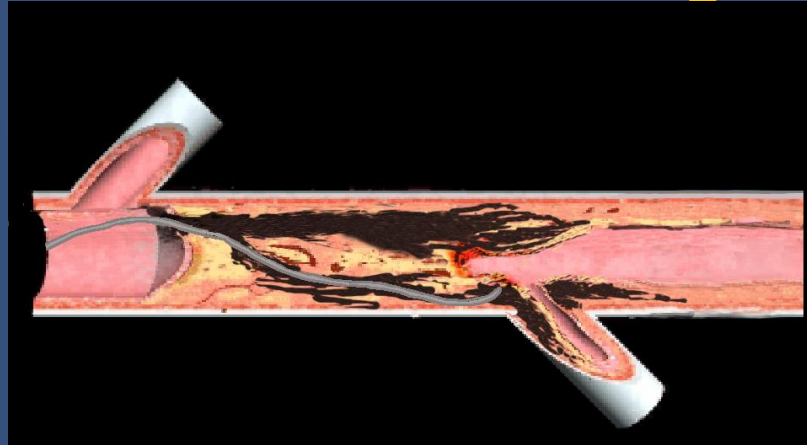

Parallel wire technique

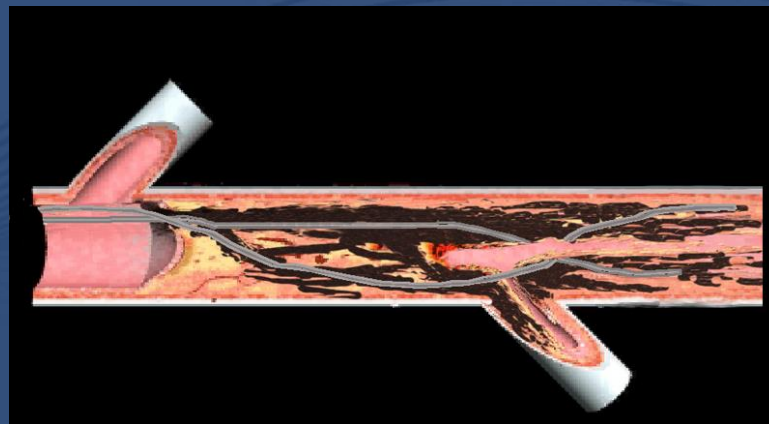

Wire Manipulation

Both hands easier than single hands manipulation

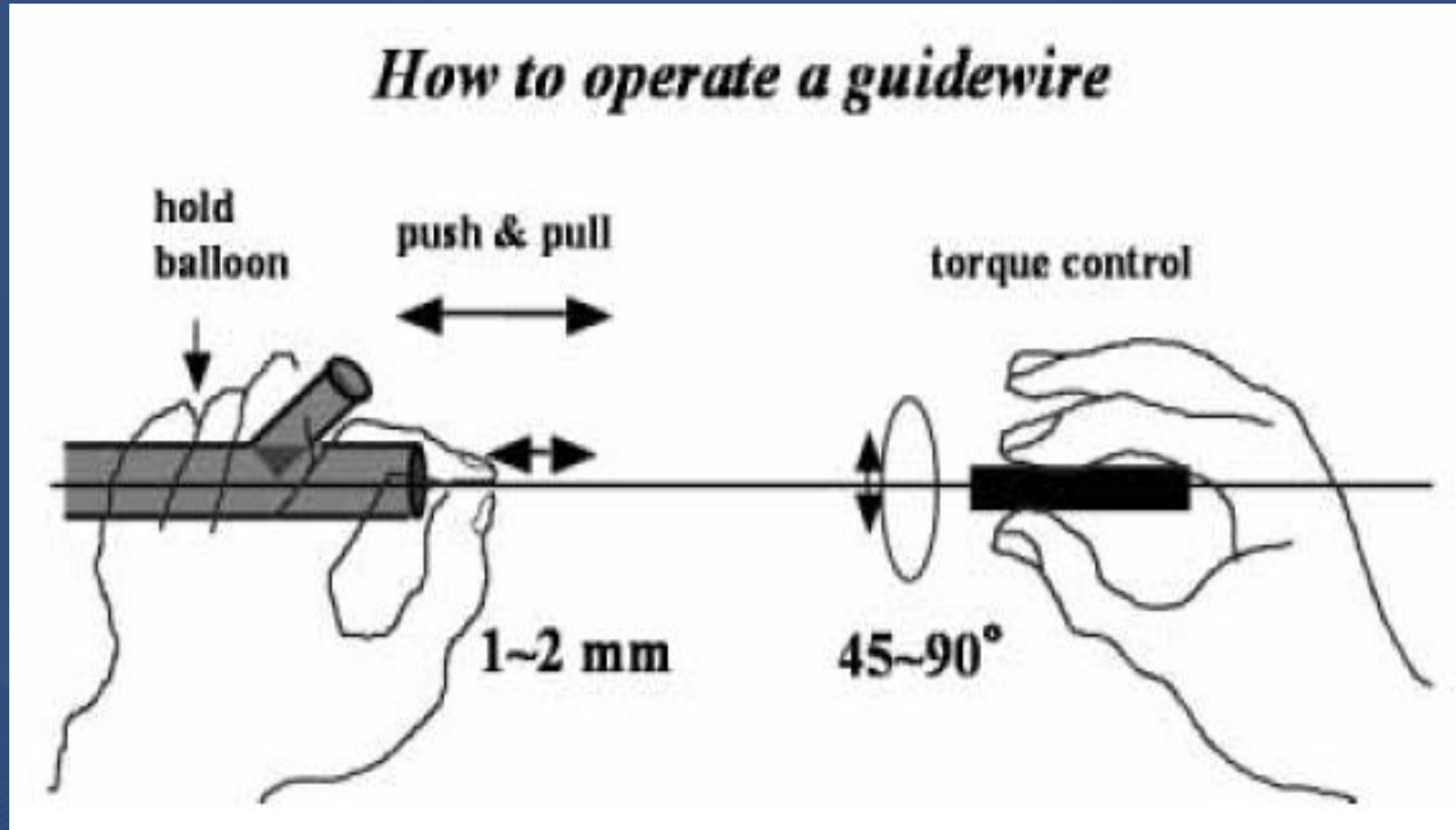

Anchor balloon technique

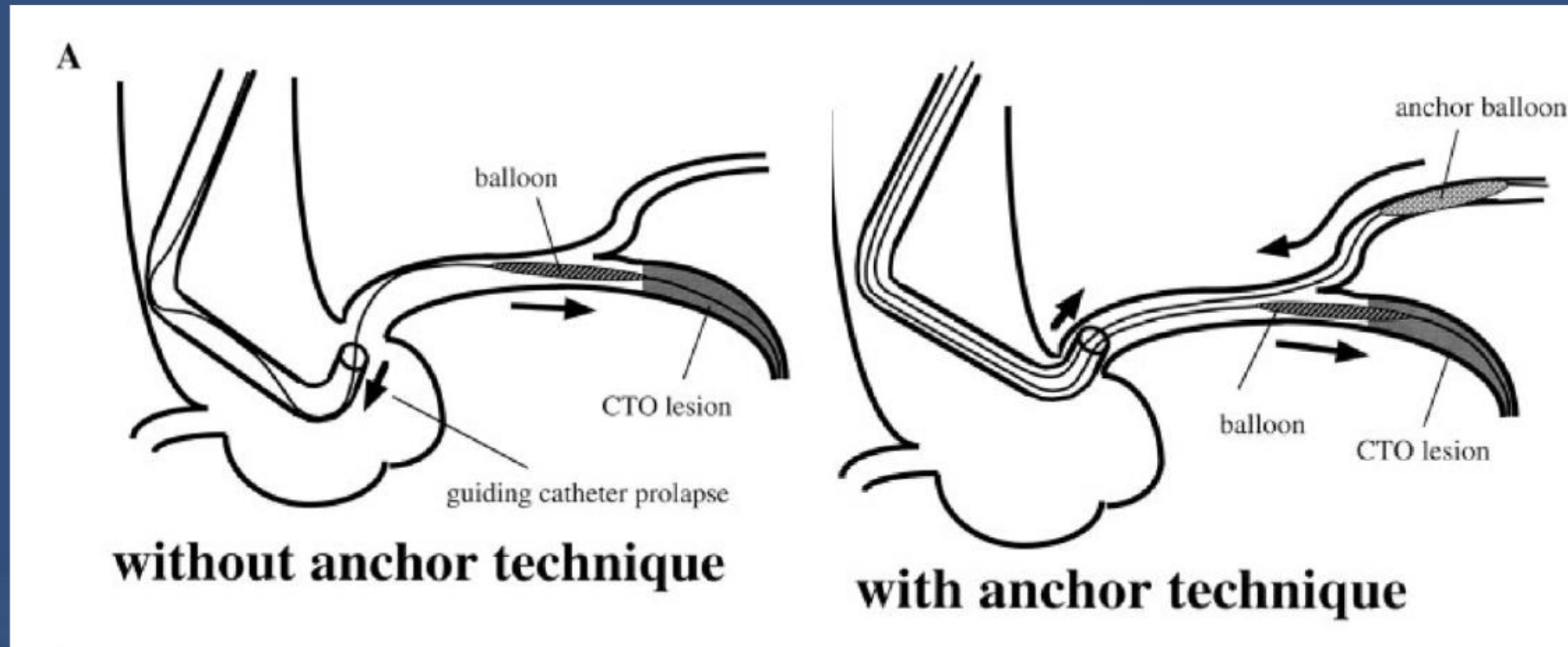

Fujita S, Tamai H et al; Cather Cardiovasc Interv. 2003;59:482-8.

Anchor Technique

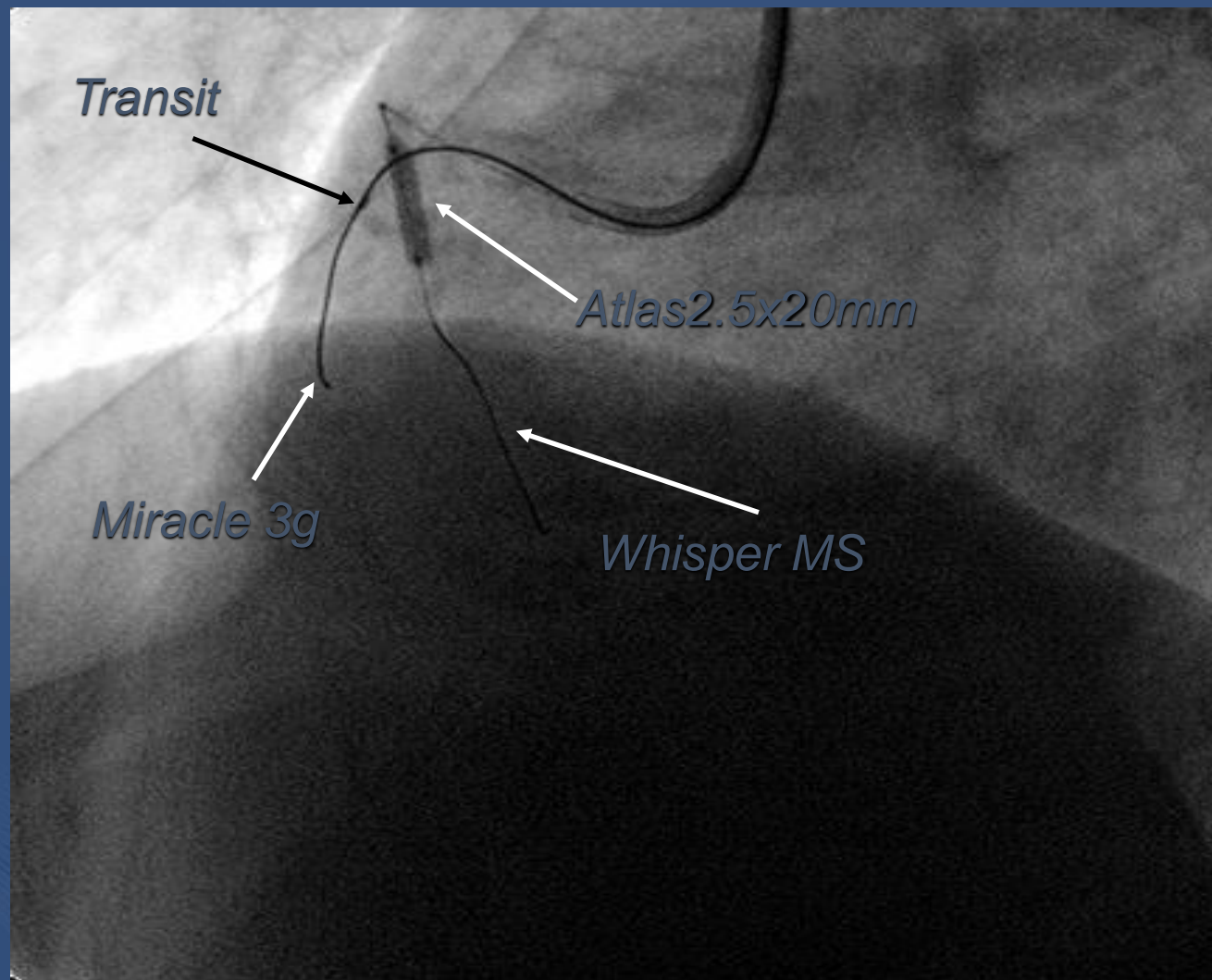

Child in Mother Catheter Technique

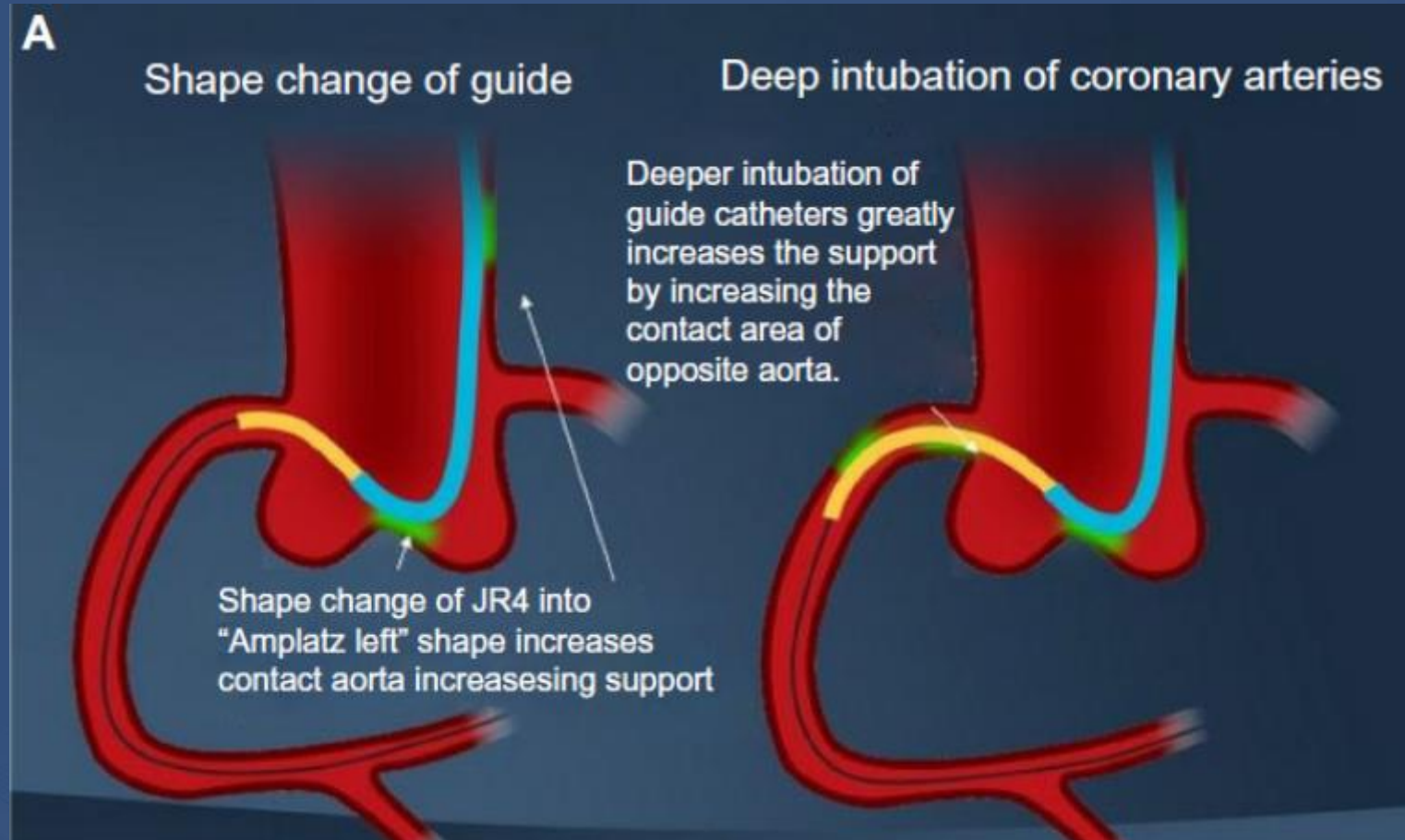

Lemos PA et al, EuroIntervention. 2013 May 20;9(1):148-56.

Child in Mother Catheter Technique

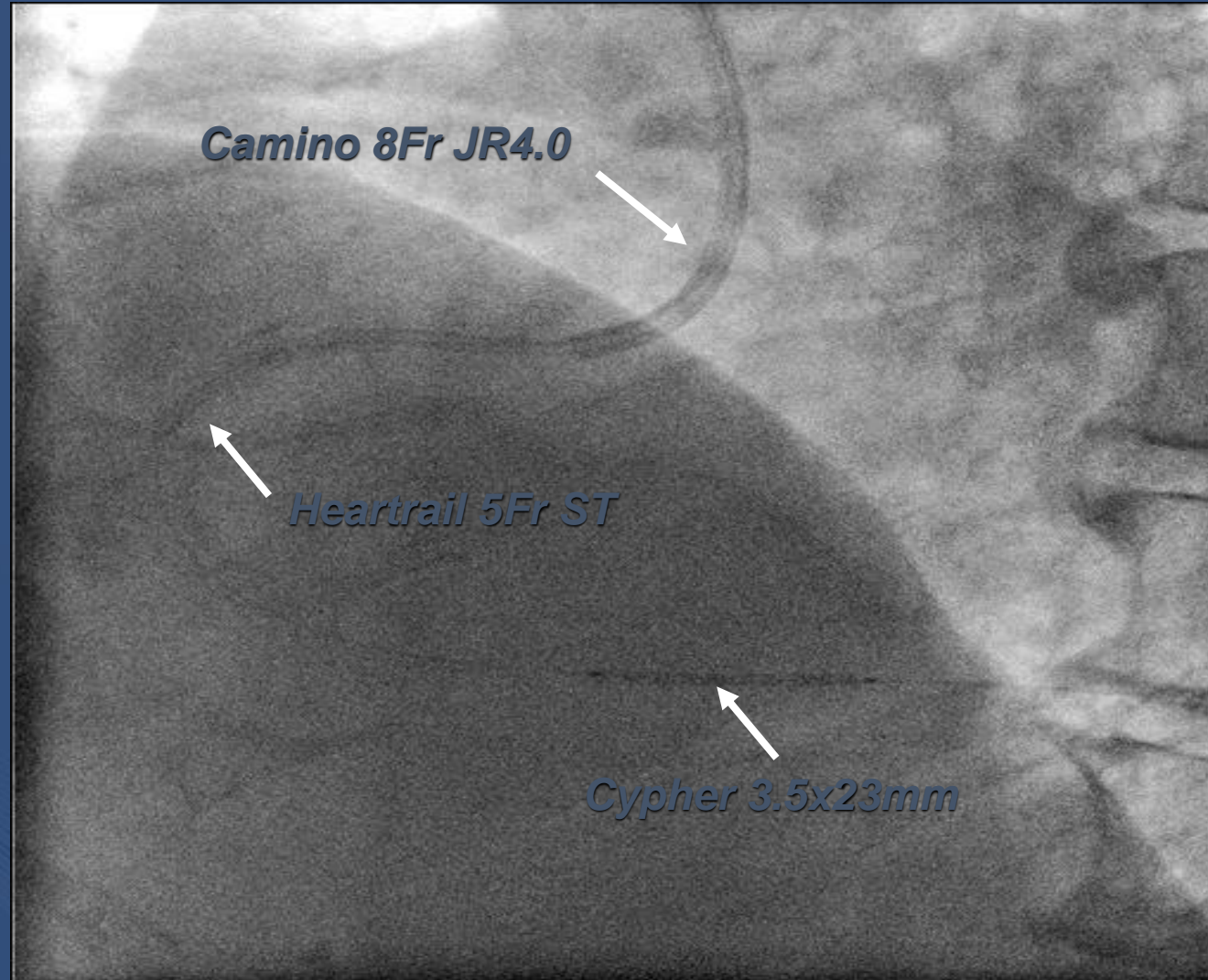

Concept of Parallel Wire Technique

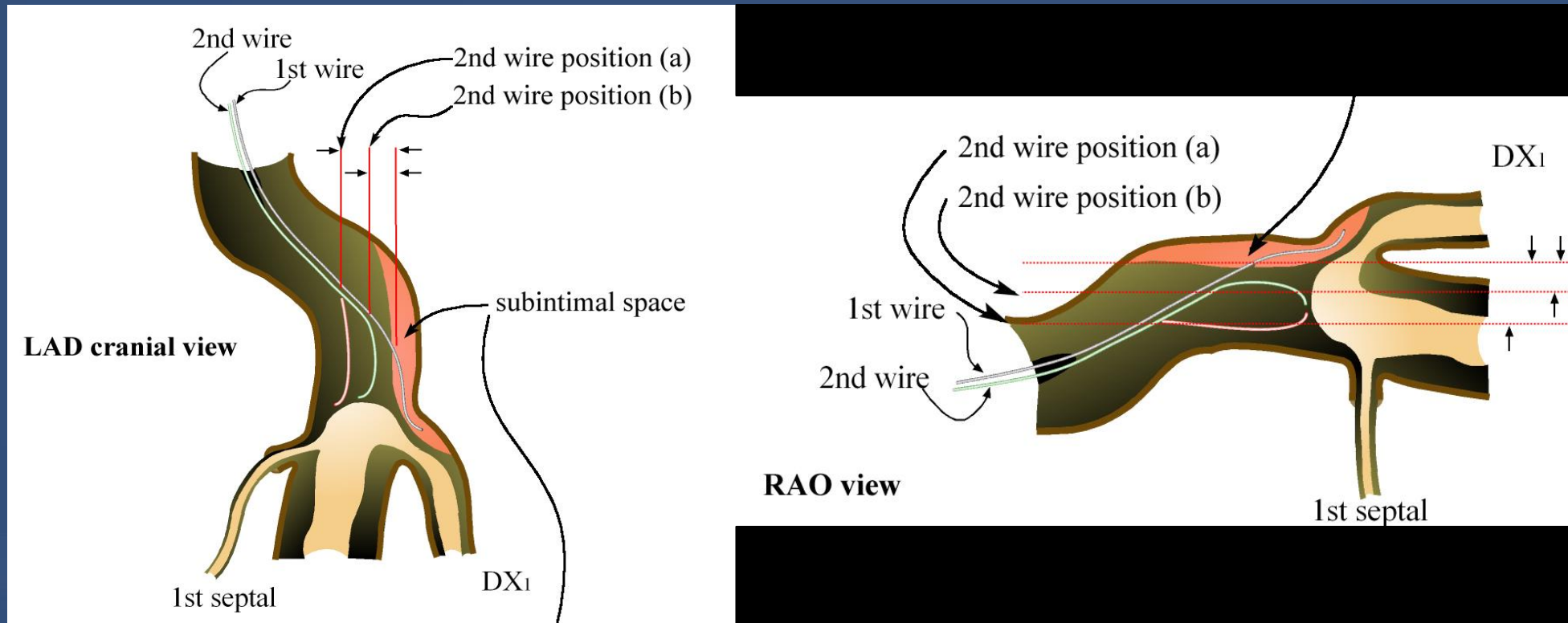

Parallel Wire Technique

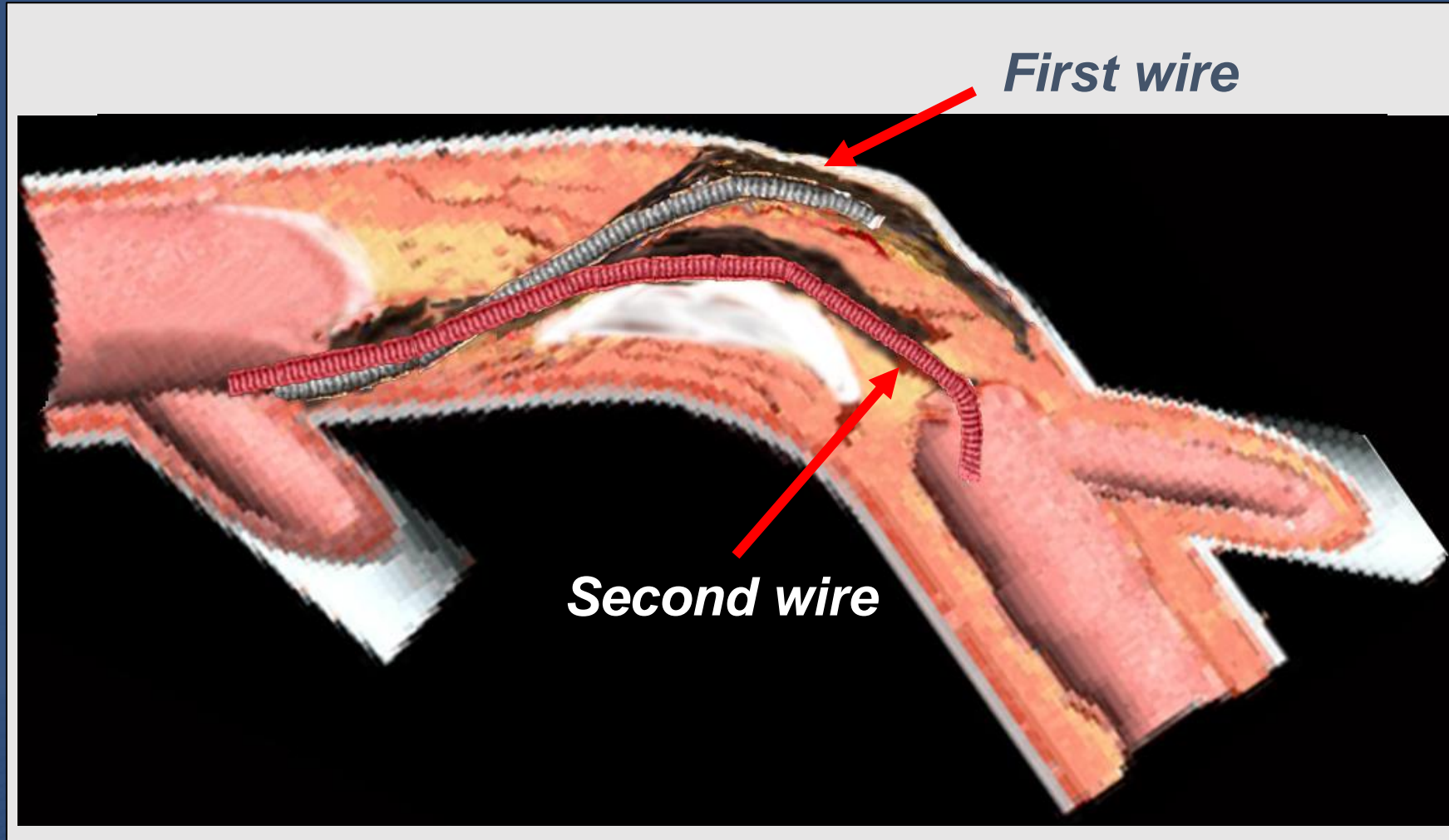

Parallel Wire Technique

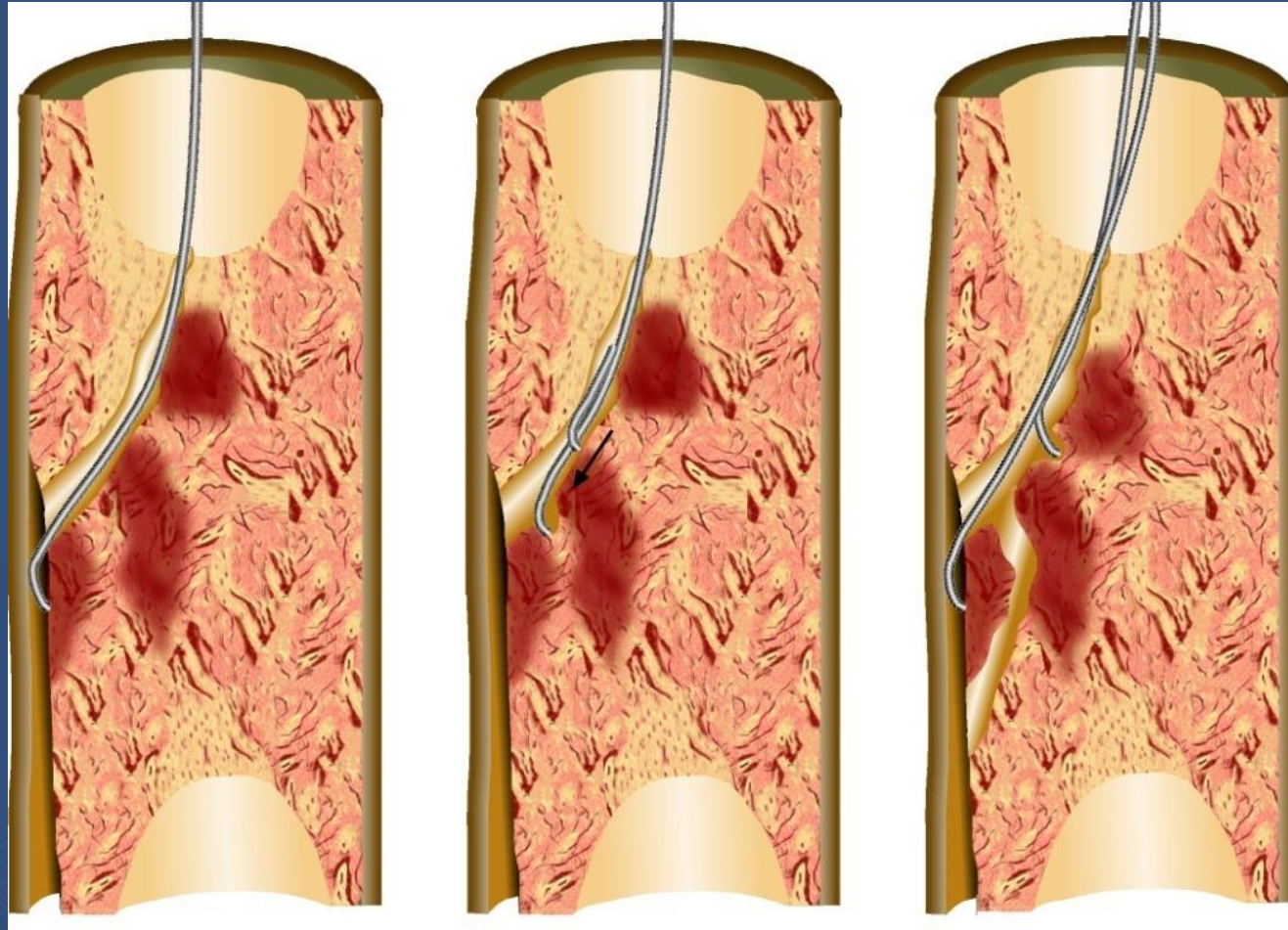

Side Branch & Parallel Wire Technique

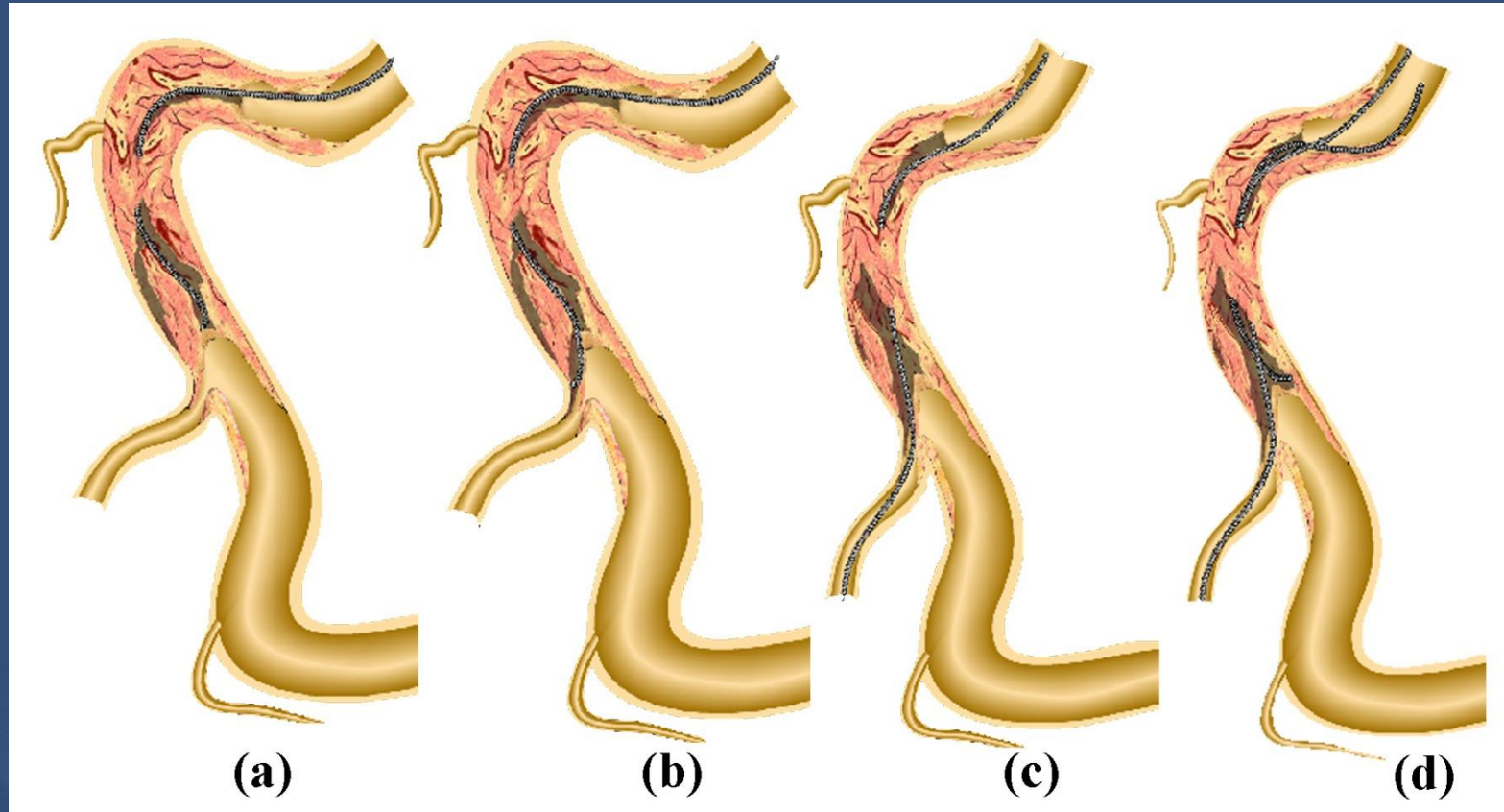

Parallel Wire Technique

Escalation of Wire

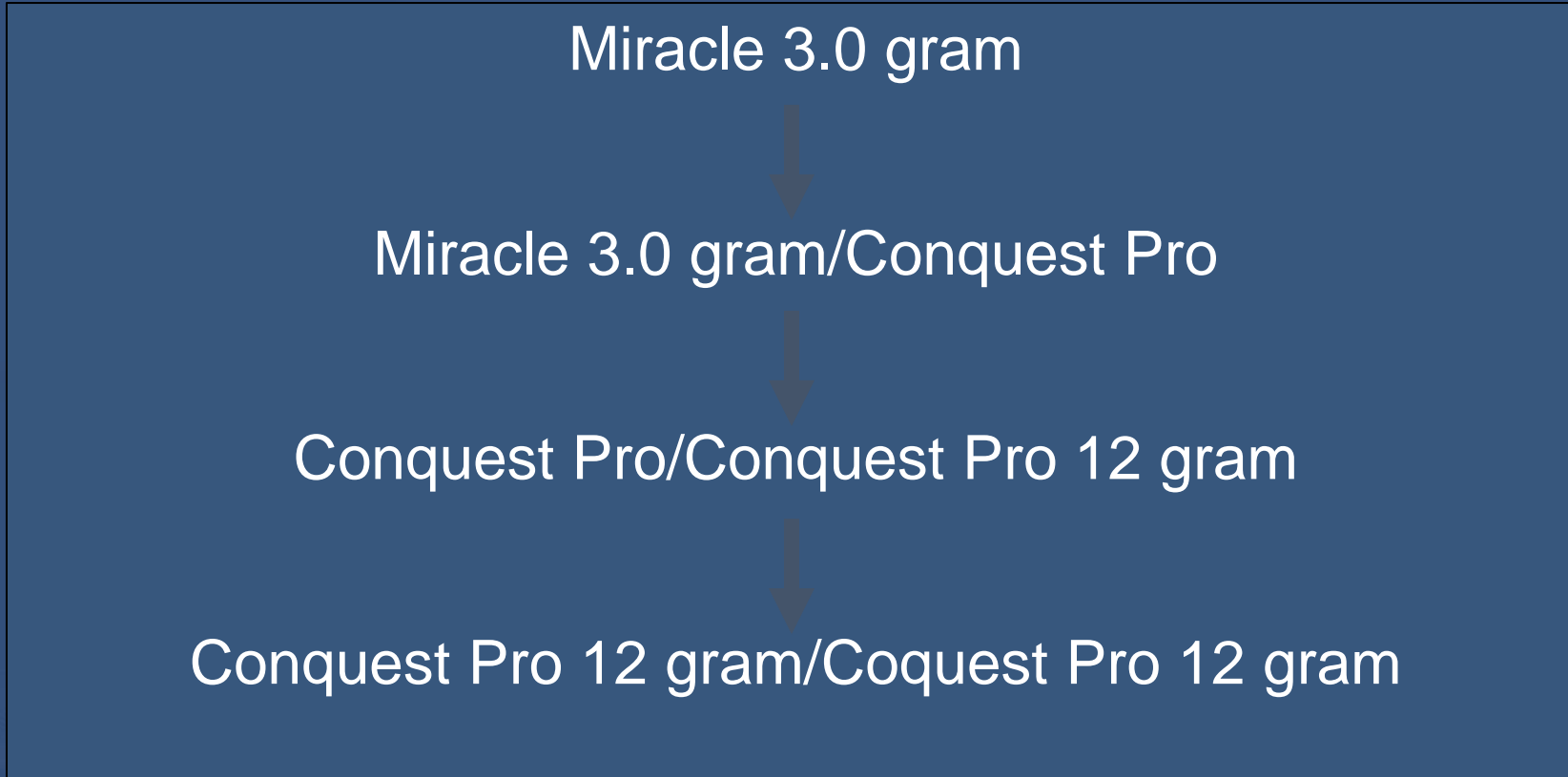

Ochiai M et al, Ital Heart J 2005;6:489-493

See-saw wiring technique

- Two support catheter at a time
- Roles of two wires be exchangeable
- Using parallel wire method with two support catheters
- Operator is able to move each of the two wires independently
- Introduces fluid (blood) into the otherwise dry occlusion site, triggering the hydrophilic mechanism, preventing wires from sticking to each other

See-saw Wiring

Parallel Wire Method with
Double Support Catheters

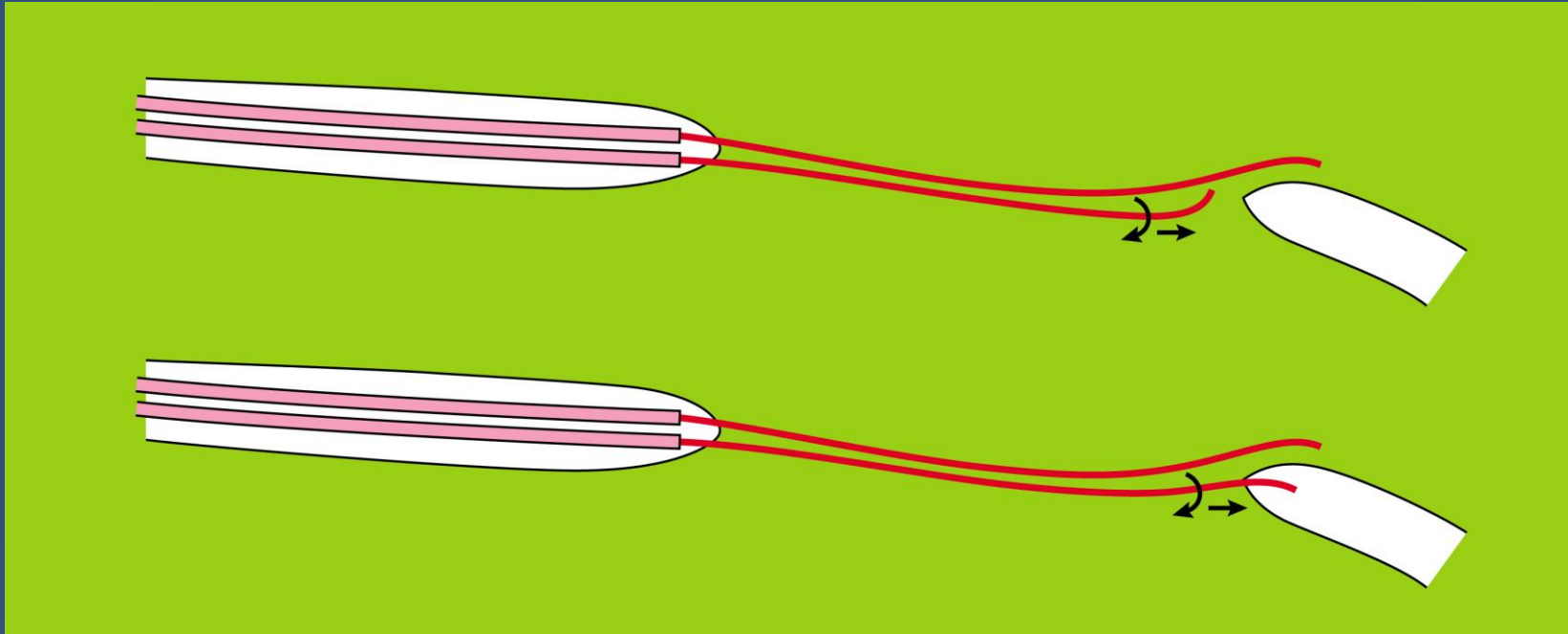

See-saw Wiring

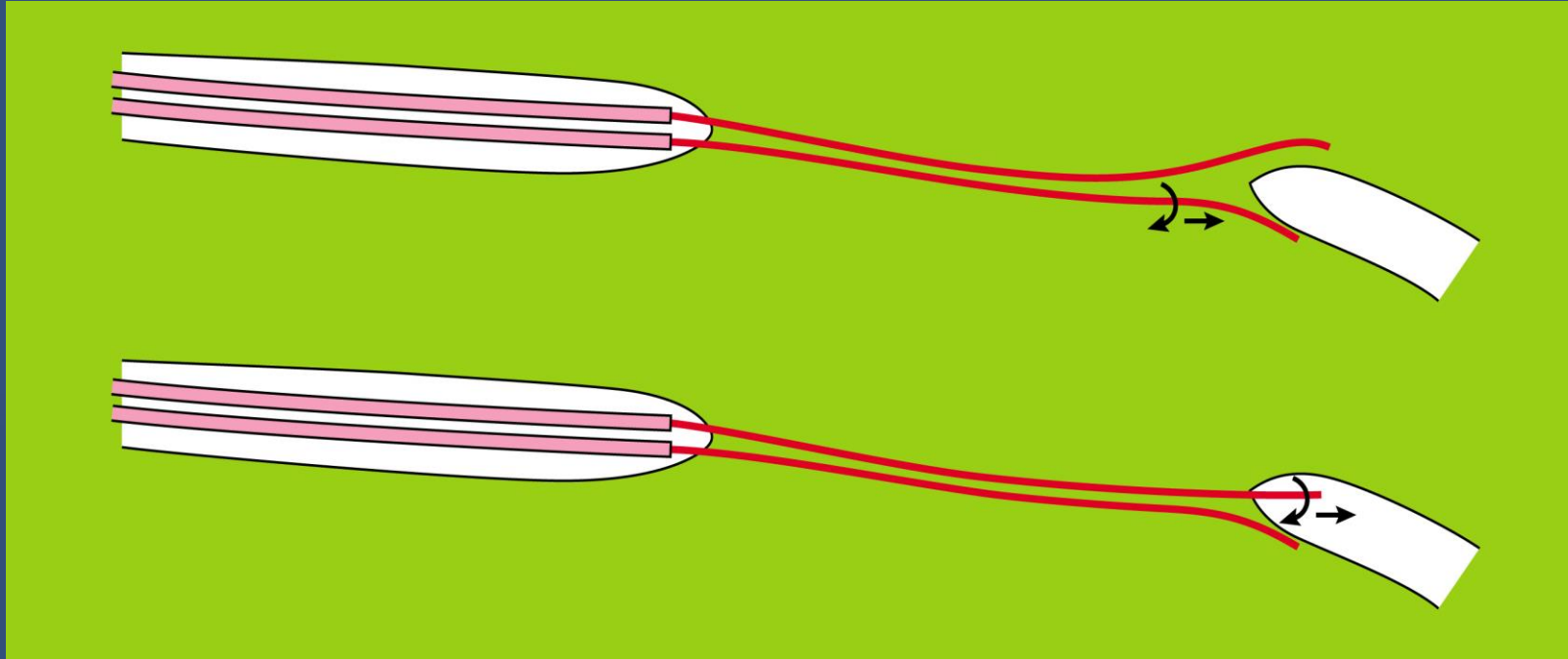

These guide wires can exchange their roles each other very easily

Side Branch Technique

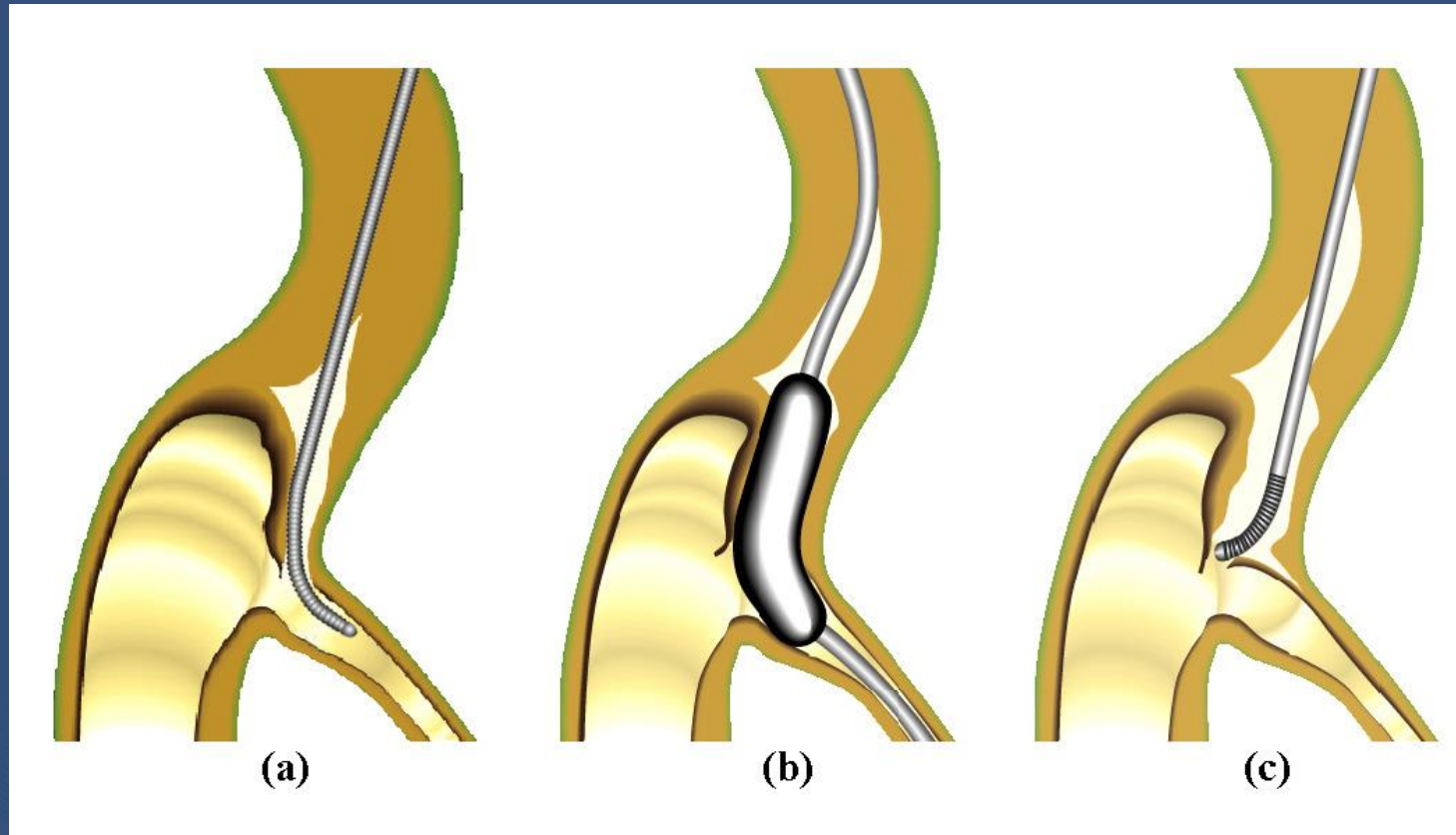

Double lumen catheter : Crusade

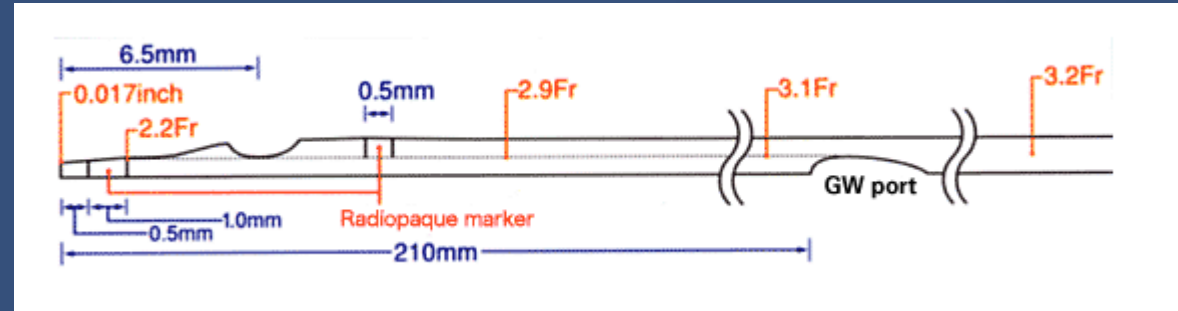

◆ Distal Tip



◆ GW Inlet (OTW Lumen)



Figure 5. An illustration of the Crusade microcatheter.

Double lumen catheter

Crusade



Bifurcation lesion

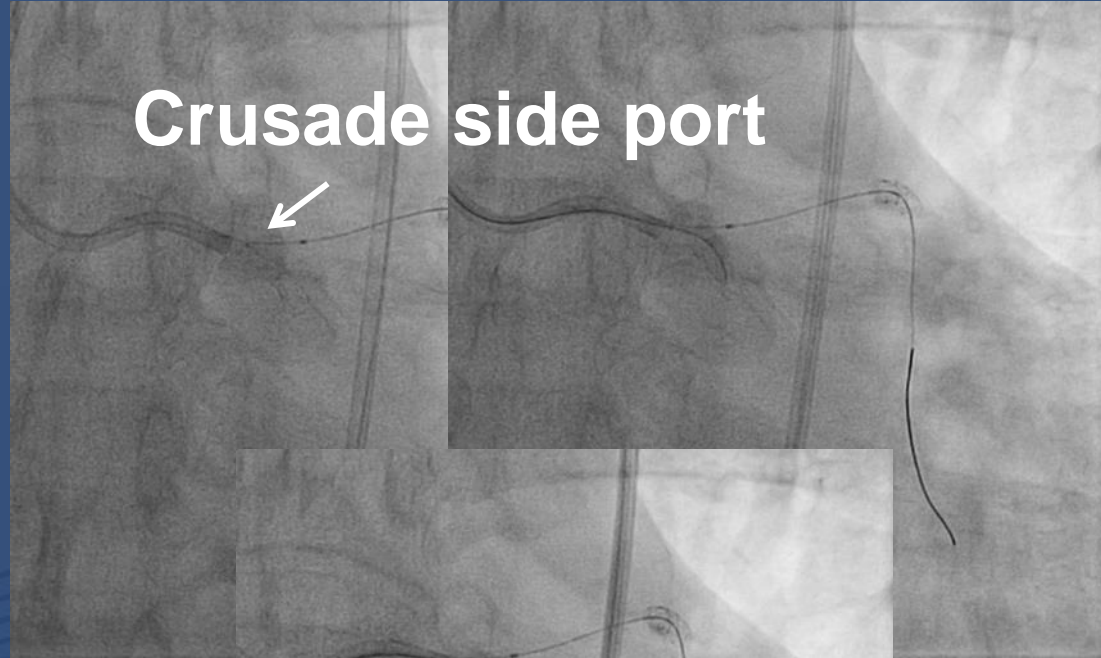

Crusade side port

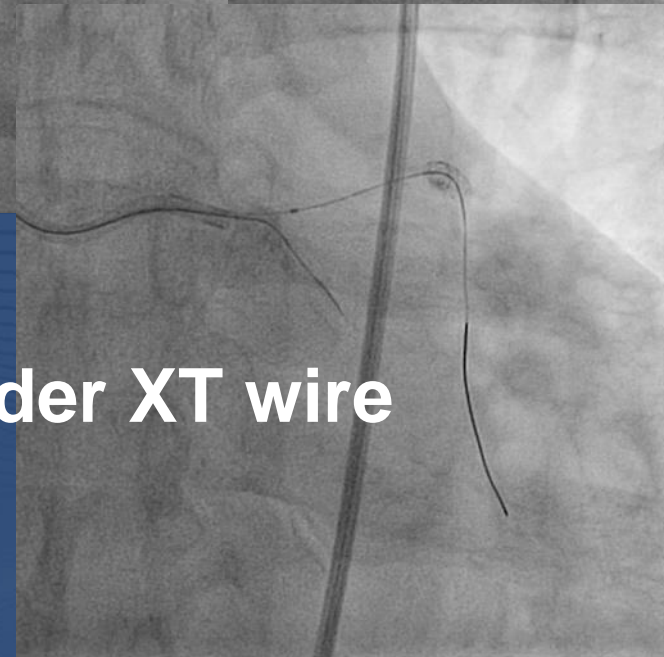

Fielder XT wire

Parallel Wire Technique

Double lumen catheter (Crusade)

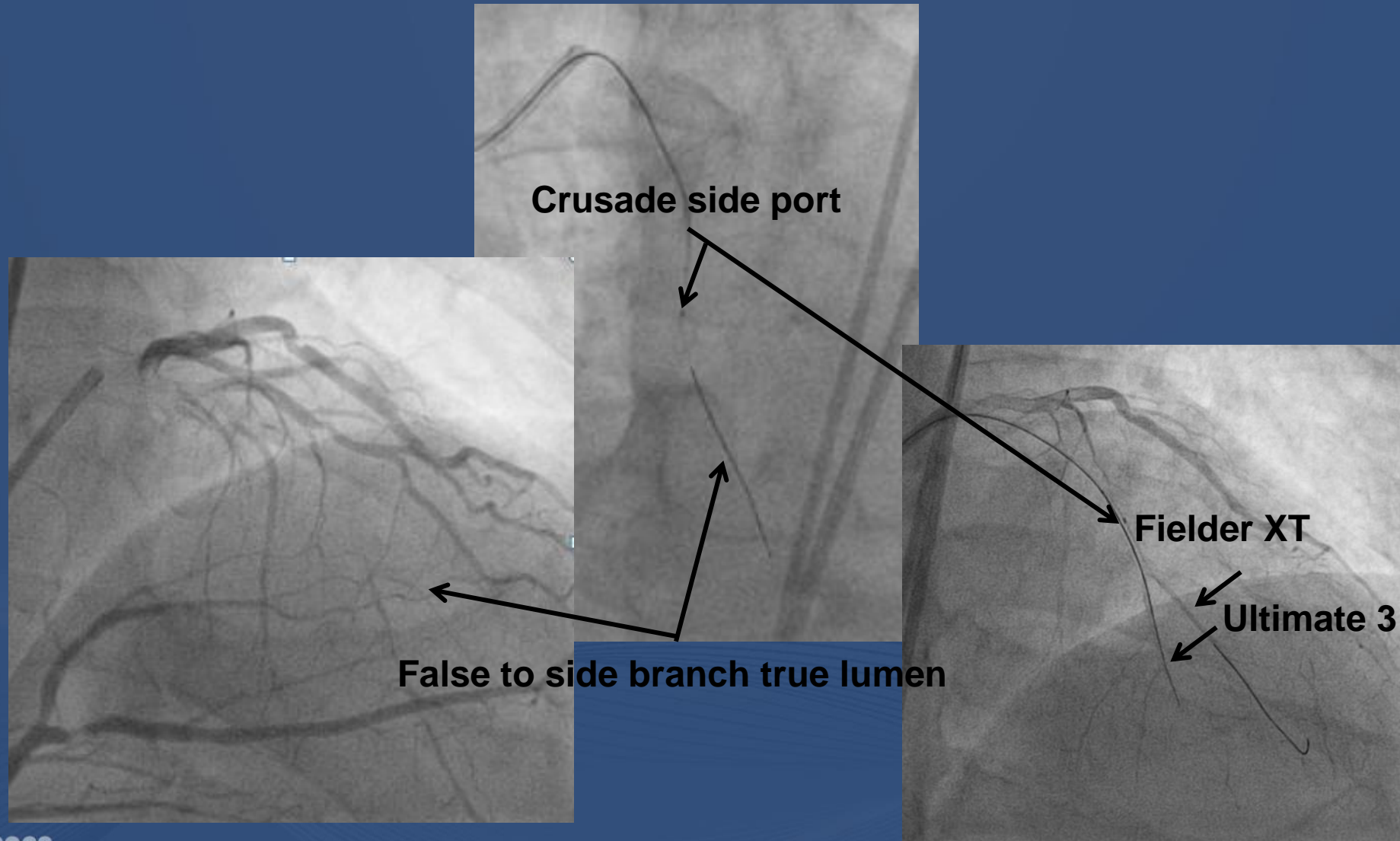

STAR Technique

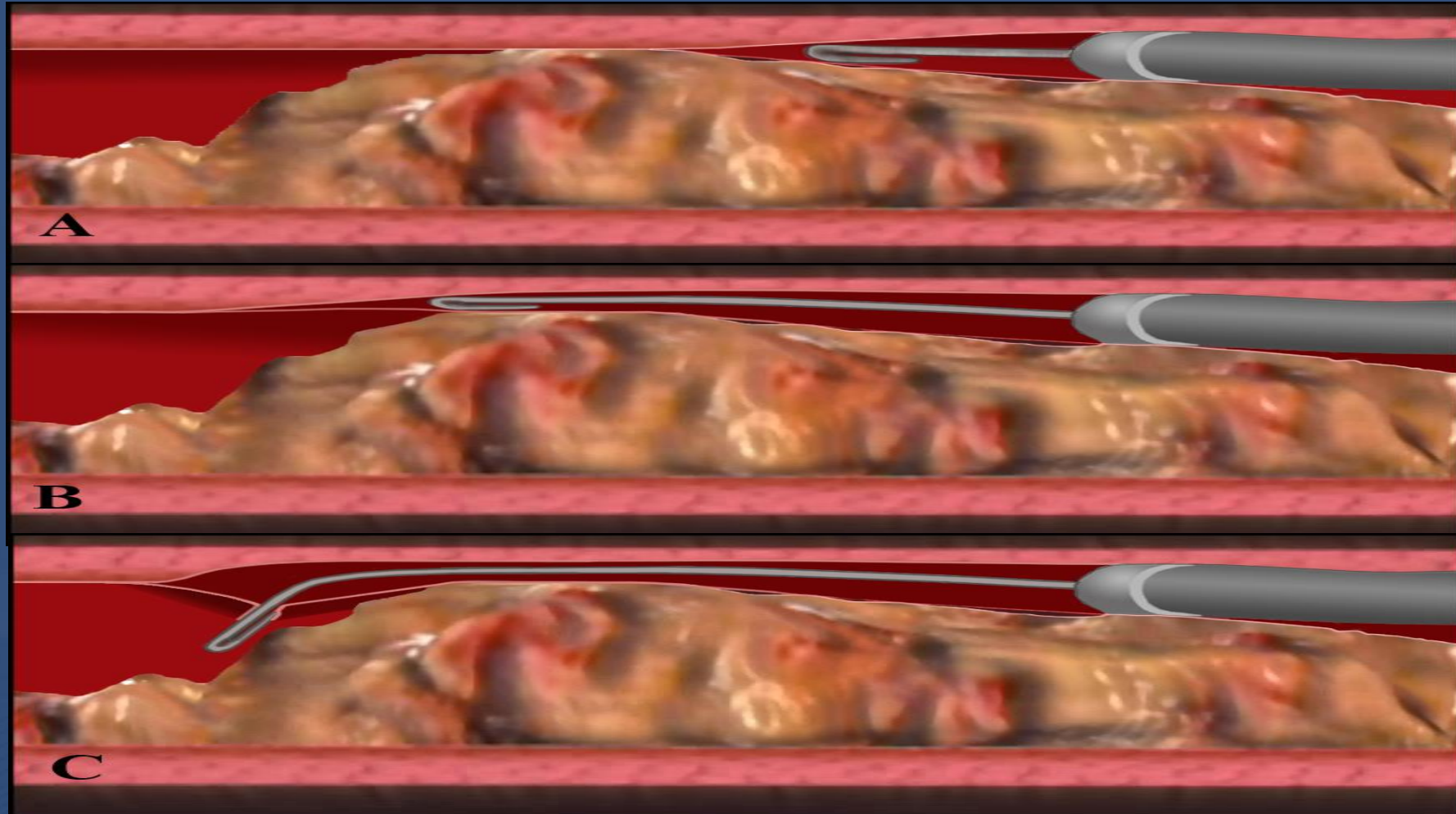

Retrograde Approach

Retrograde Approach

- if anterograde approach is applied -

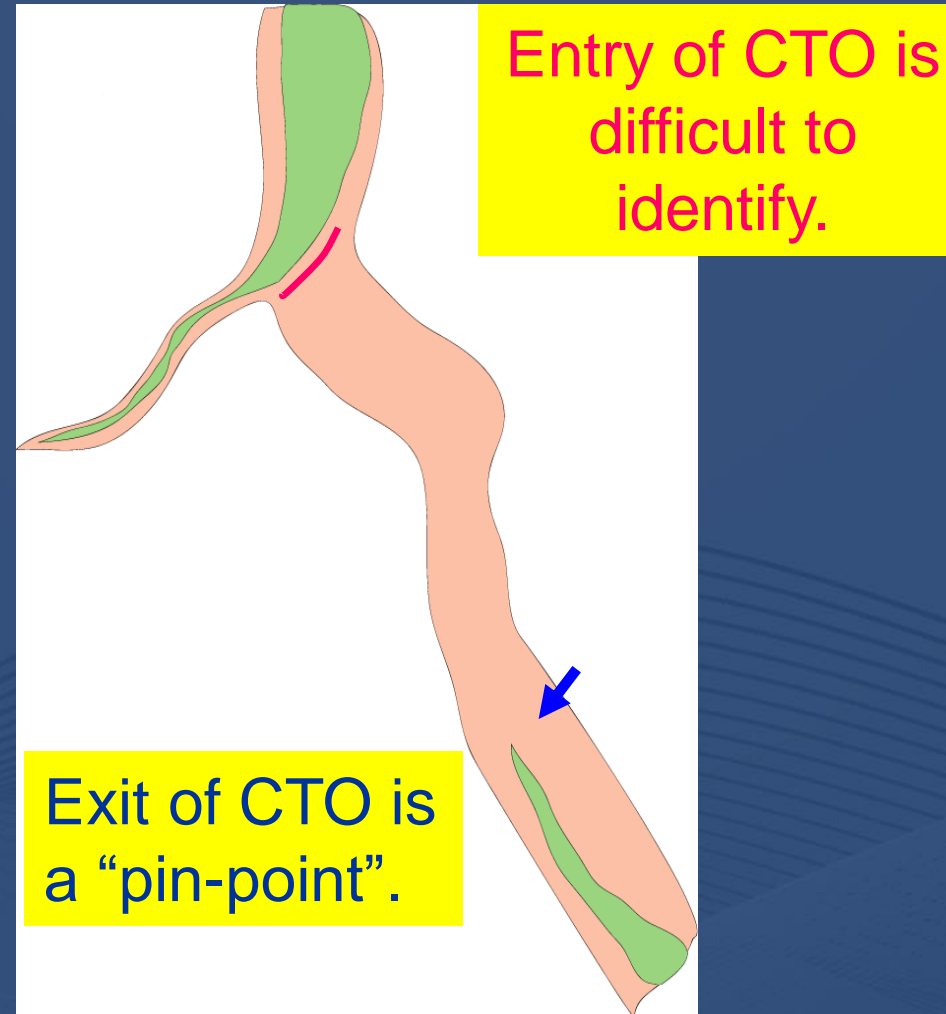

Retrograde Approach

- if retrograde approach is applied -

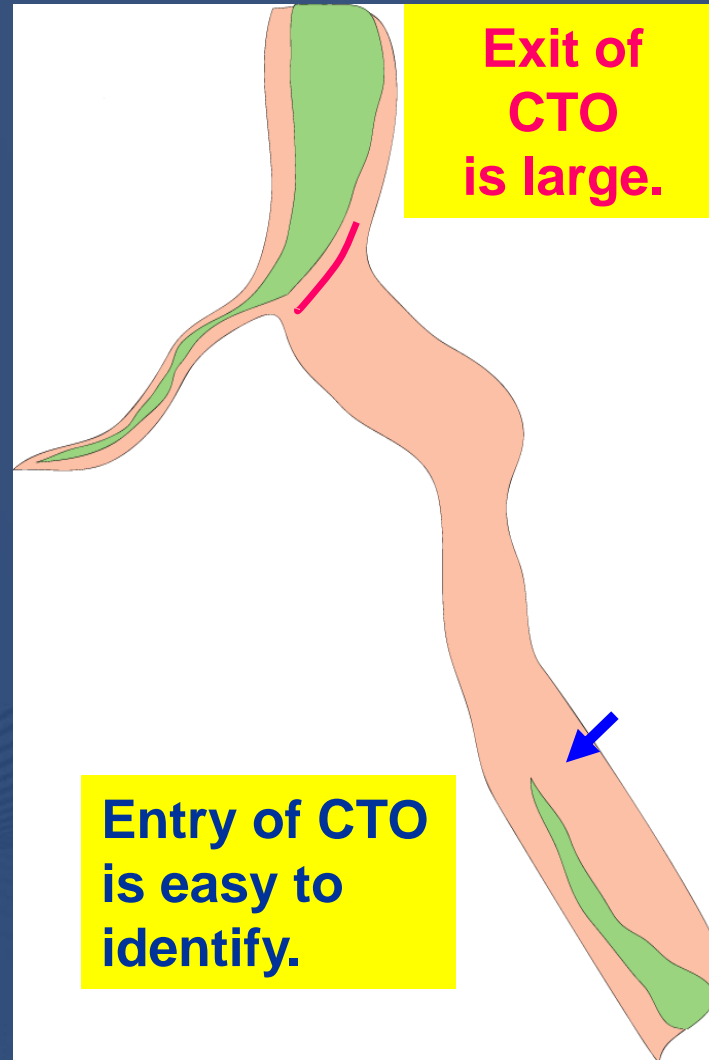

Procedure Sequence of Retrograde Approach

1st step : Connection channel crossing

- 1) Branch selection
- 2) Wiring through target collateral

2nd Step : Micro-catheter delivery to distal CTO

3rd Step : Retrograde wiring in CTO lesion

- 1) Retrograde guide-wire crossing
- 2) Kissing wire technique
- 3) Reverse CART technique

Principles with collateral channels (CC)

- 1. Septal CCs
 - Safer than epicardial CCs: try first
 - Straight is better, tortuosity is more an issue
 - You CAN wire invisible CCs

- 2. Epicardial CCs
 - Larger size is important
 - Tortuosity less an issue
 - Lower threshold post CABG if course is outside the AV groove:
unlikely tamponade in case of CC perforation

Septal “surfing” technique

- Involves placing
 1. **workhorse wire** in proximal CC
 2. microcatheter (Corsair or FineCross),
 3. “surf” with a **Sion or Fielder FC** for **low resistance** connection (no wedged tip injection)

- Help crossing **even invisible CCs**
 - Recipient vessel angle not visible is **much less** an issue

Epicardial CC wiring

- Adding a second tiny bend more proximal may help
- Sion has emerged as the wire of choice
- Keep wire free and moving
- Follow the path of least resistance

Classification Retrograde Procedures

Dilatation of CTO Body	Direction of Wire Crossing	
	Retrograde	Antegrade
(+)	Reverse CART	CART
(-)	Retrograde Wire Crossing	Kissing Wire

		Antegrade	Retrograde
Dilation before Wire Cross	NO	<p>Kissing Wire Cross</p> <p>A</p>	<p>Retrograde Wire Cross</p> <p>B</p>
	YES	<p>CART</p> <p>C</p>	<p>Reverse CART</p> <p>D</p>

Options After Retrograde Guidewire Reaches The CTO Distal True Lumen

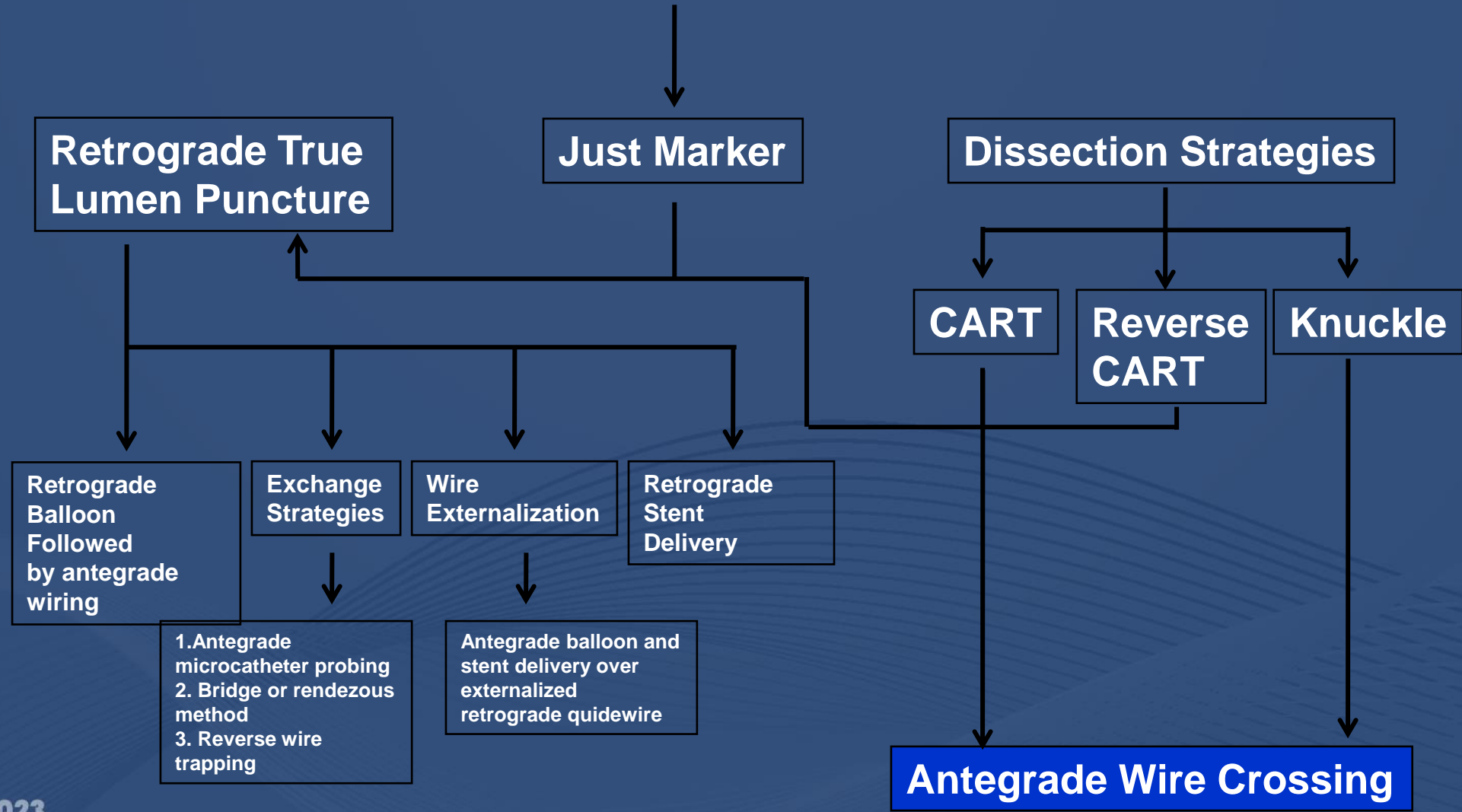

The Strategy for Complex CTO

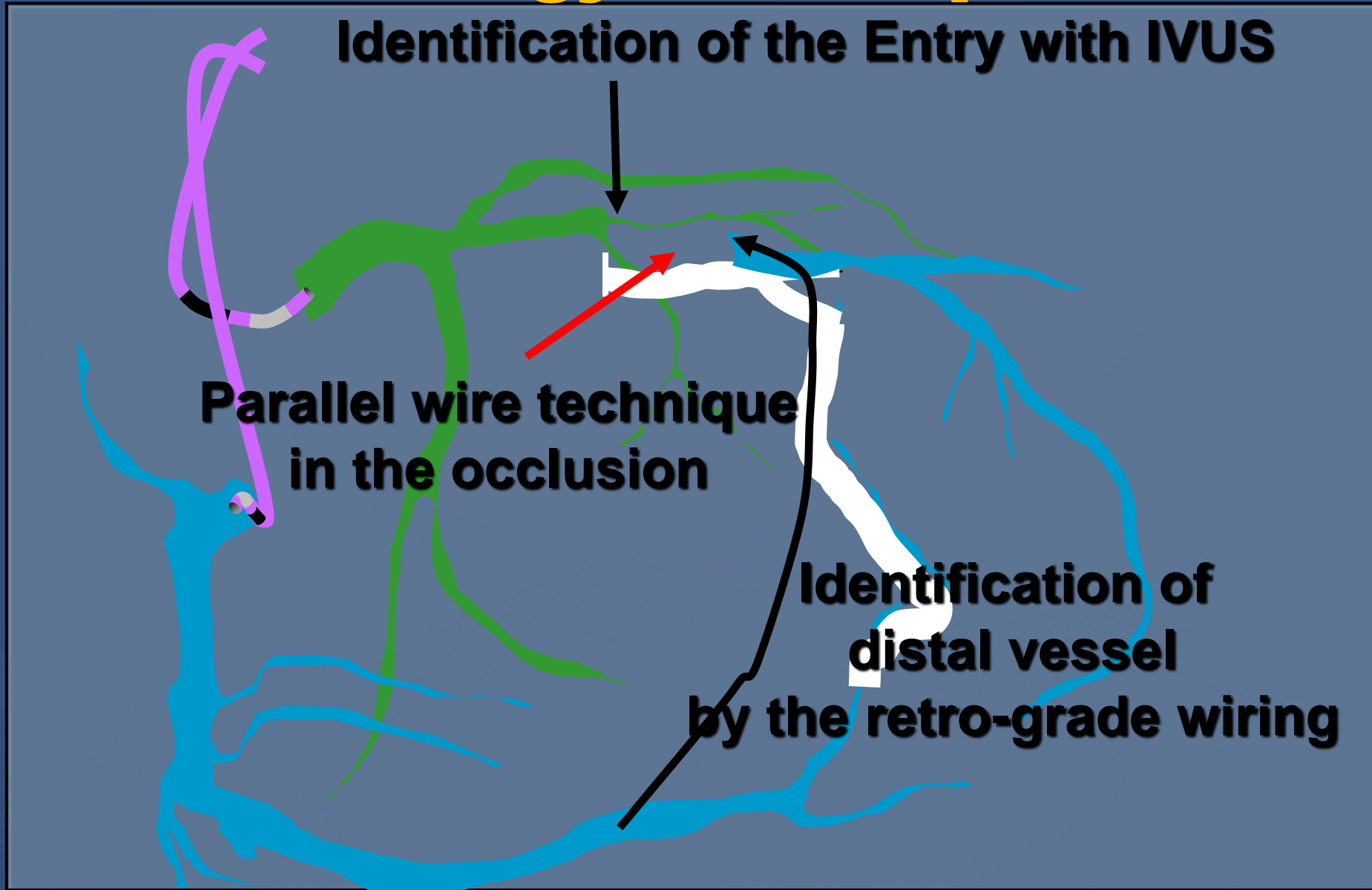

What to do if the Distal Lumen is Compressed

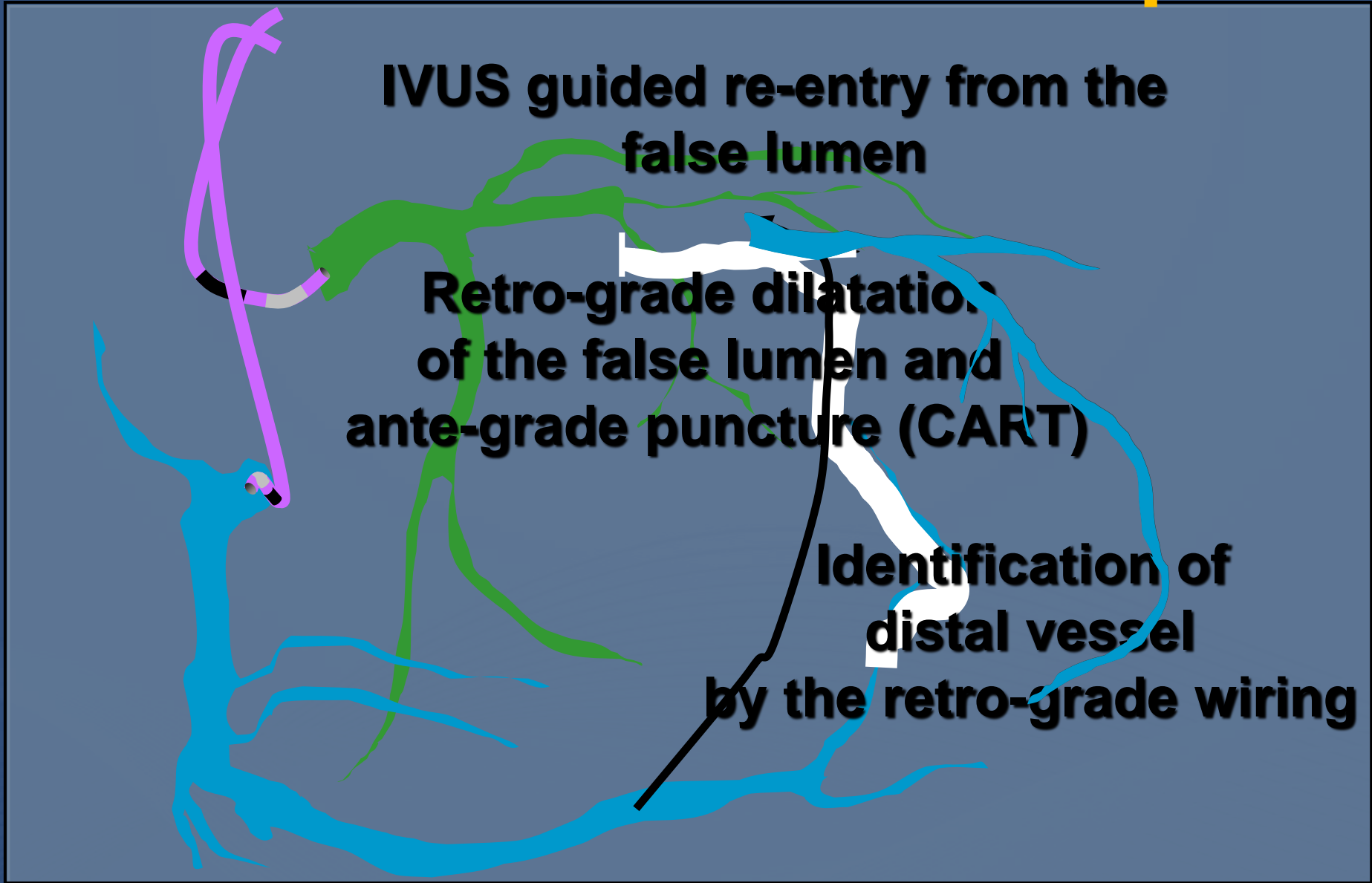

Concept of CART technique

- Controlled Antegrade and Retrograde subintimal Tracking -

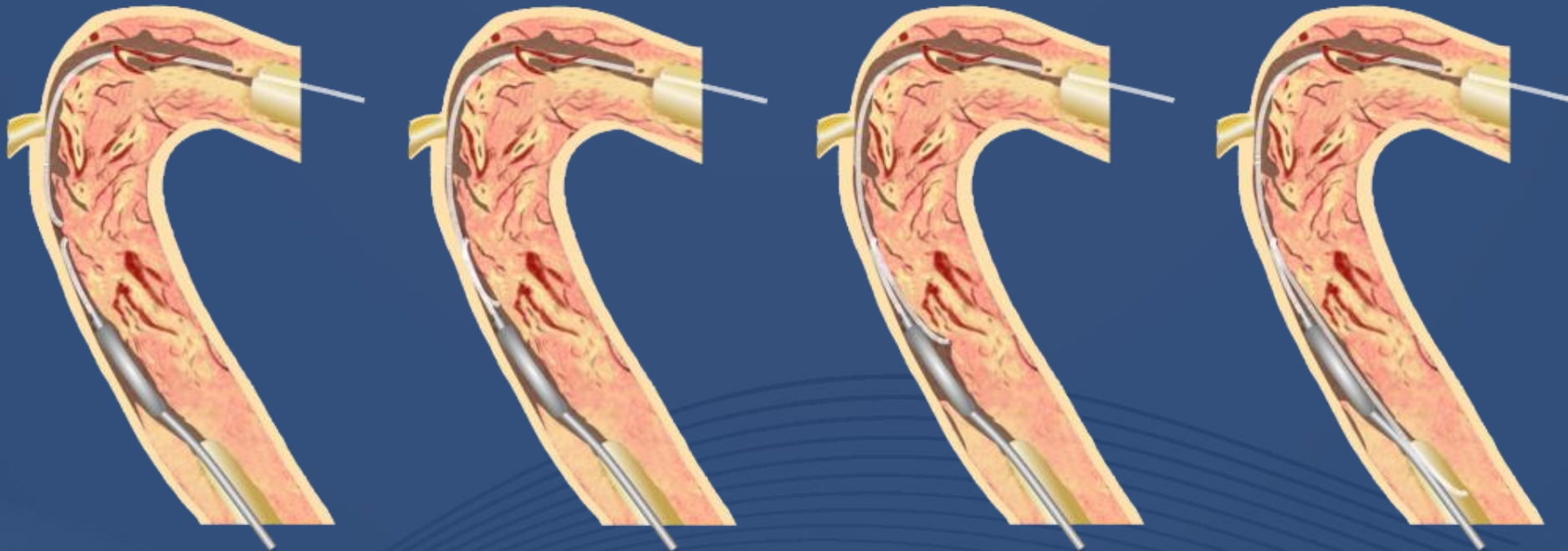

- Make connection between antegrade and retrograde subintimal space utilizing behavior of subintimal dissection.
- Antegrade wire automatically gets into distal true lumen.

CART & Reverse CART technique

Standard CART

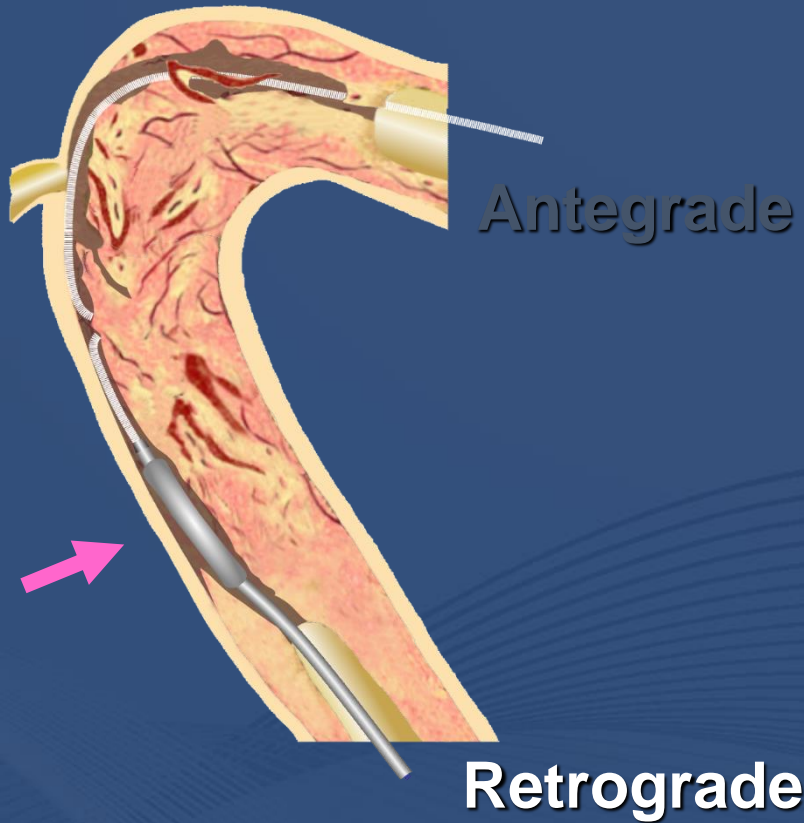

Reverse CART

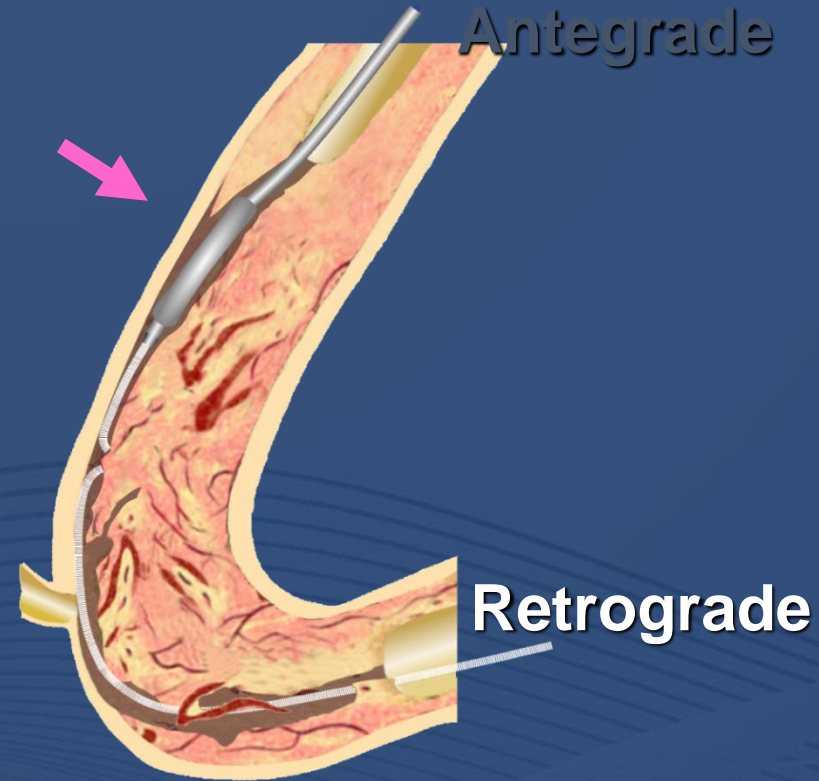

J Invasive Cardiol 2006;18:334-8

Concept of CART technique

- Controlled Antegrade and Retrograde subintimal Tracking -

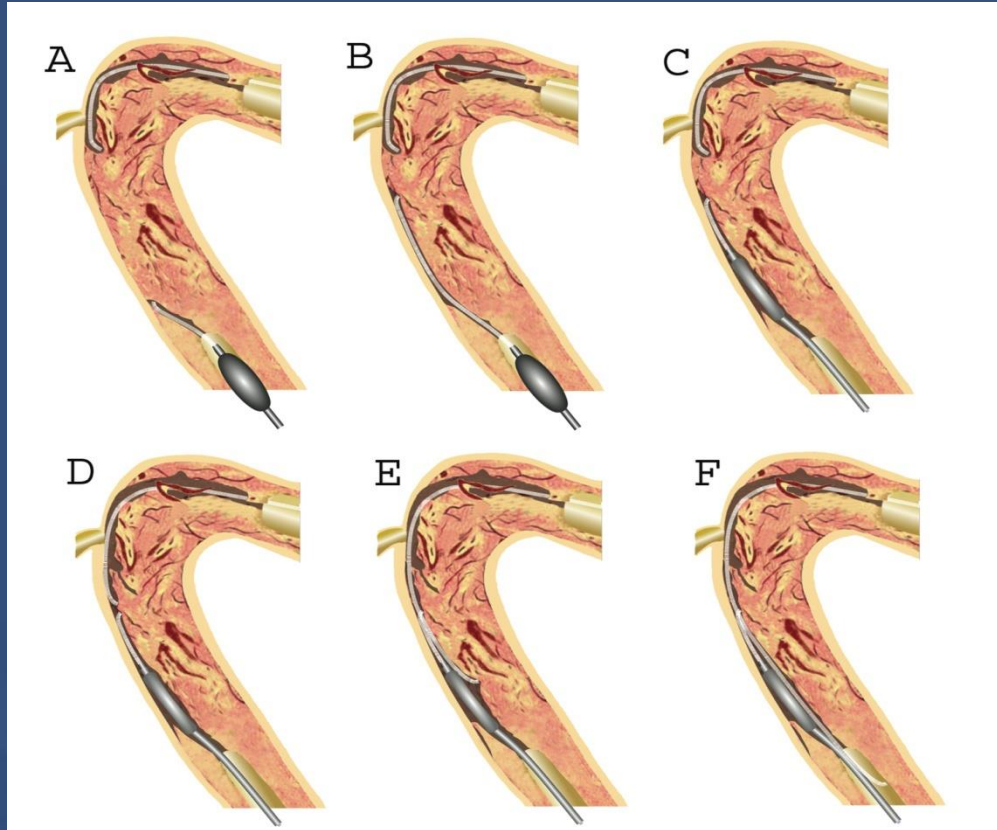

- Easy to get into CTO retrogressively
- Easy to navigate through CTO with relatively soft wire exchangeable
- Promising way to get a distal lumen (no subintimal dilatation outside CTO)
- Guarantee for getting true lumen at distal end of CTO despite any lesion morphology

Surmely JF. J Invasive Cardiol. 2006 Jul;18(7):334-8.

Retrograde Approach

Different strategies after crossing a guidewire

- Kissing guidewire
- Just landmark
- CART & reverse CART
- Retrograde true lumen tracking
- Retrograde proximal true lumen puncture
- Catching the retrograde guidewire

Saito S. Cath Cardiovas Interv 2007

Concept of Kissing Wire Technique

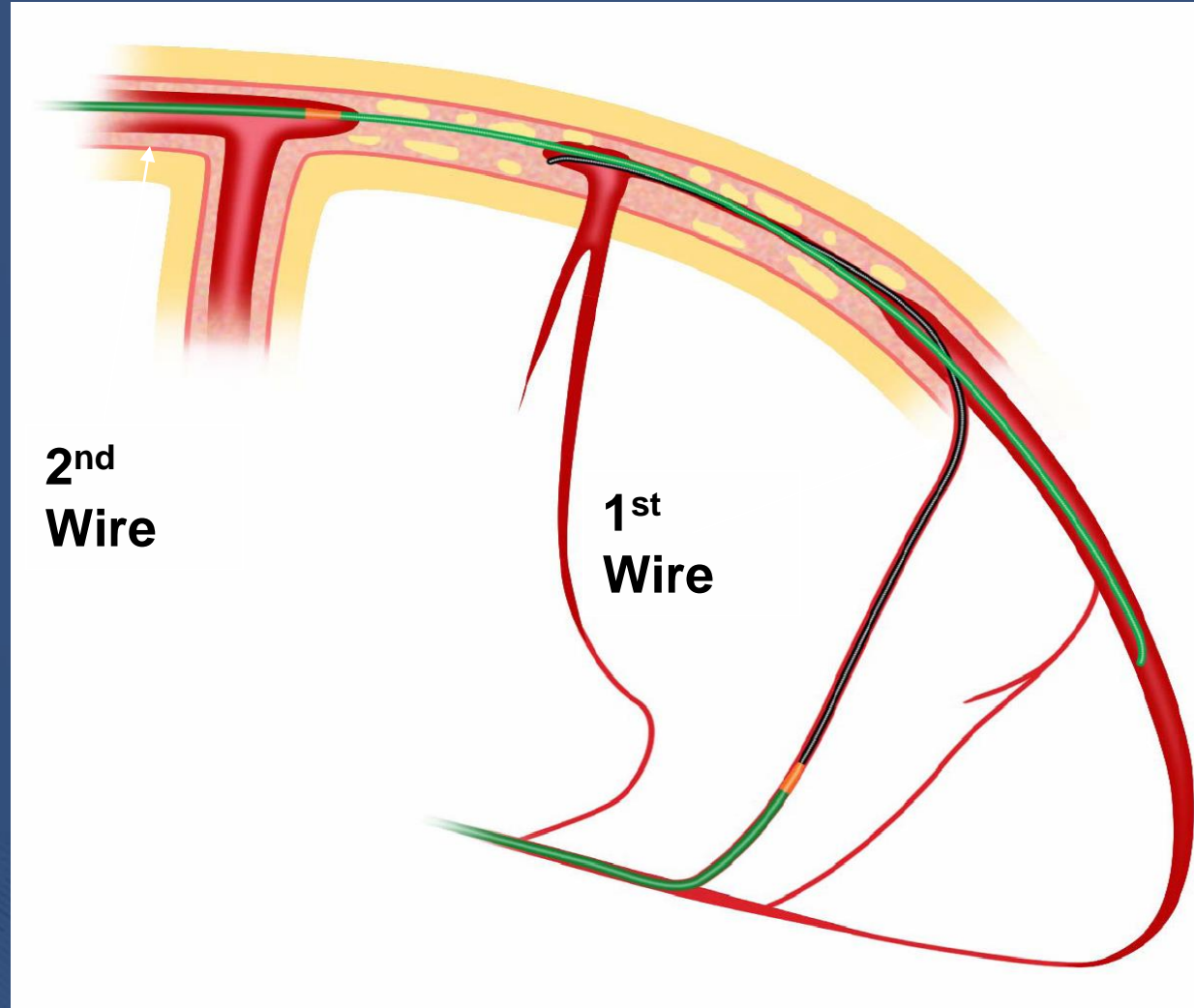

Femoral or Radial approach

Femoral Or Radial Approach in Treatment of Coronary Chronic Total Occlusion

- Patients screened for FORT CTO (n=800)

•Excluded (n=190)

- ACS within 3 months (n=103)
- Unable to obtain written informed consent(n=78)
- Unable to stay in a recumbent position for at least 1 hour (n=5)
- IABP usage (n=2)
- Severe renal failure (n=2)

Patients randomized in the FORT CTO trial (n=610) by ITT analysis

N = 305

N = 305

Allocated to Radial approach

Allocated to Femoral approach

Femoral Or Radial Approach in Treatment of Coronary Chronic Total Occlusion

CENTRAL ILLUSTRATION Main Findings of Femoral or Radial Approach in the Treatment of Coronary Chronic Total Occlusion

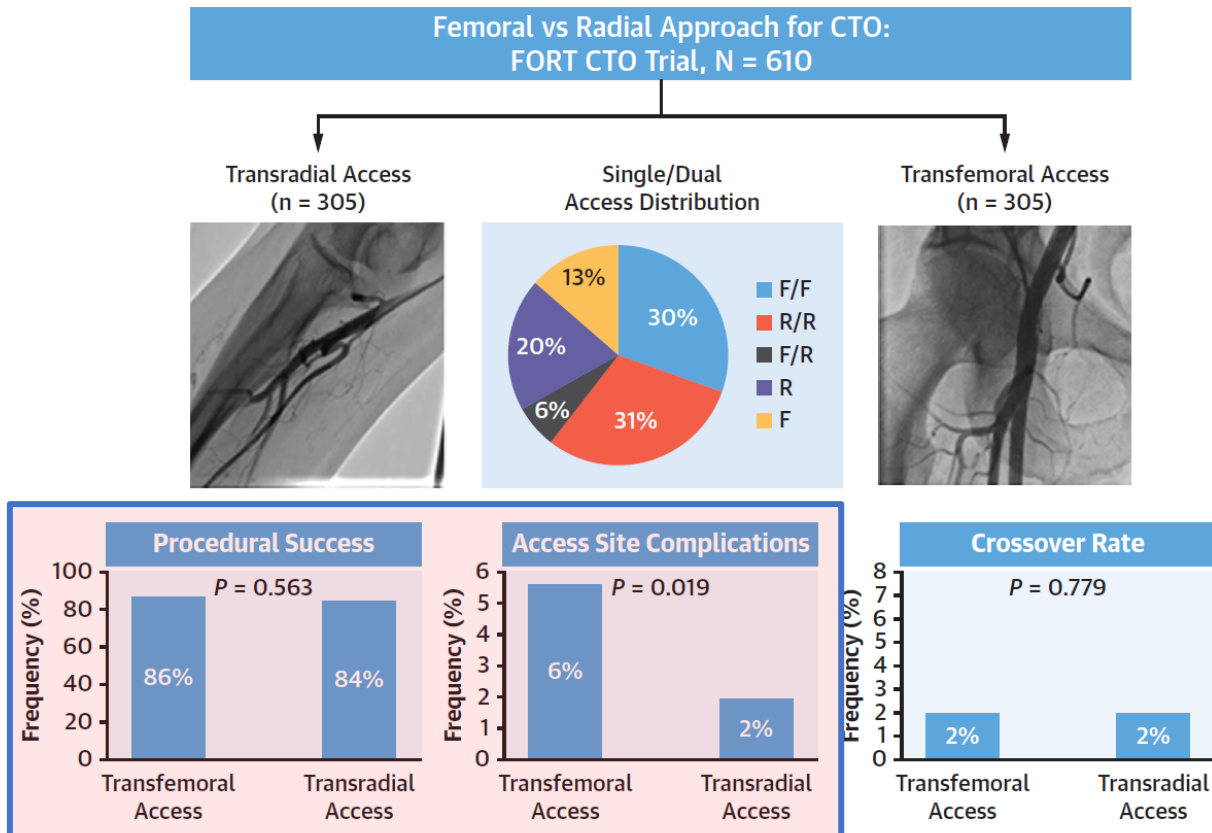

Gorgulu S, et al. *J Am Coll Cardiol Interv.* 2022;15(8):823-830.

CTO = chronic total occlusion; F = femoral; F/F = femoral/femoral; F/R = femoral/radial; FORT CTO = Femoral or Radial Approach in the Treatment of Coronary Chronic Total Occlusion; R = radial; R/R = radial/radial.

IVUS assisted Procedure

IVUS guided intralesional rewiring

- **Antegrade**
- Retrograde *... tomorrow*
- **Integration of IVUS and Angiogram**
 - Use IVUS information for wire control
- **Histology**
 - Intimal plaque
 - Subintimal space

IVUS guided rewiring

- Longitudinal position for optimal rewiring
- Direction of rewiring in IVUS
- Direction of rewiring in Angiogram
- Wiring
- Confirm wire position by IVUS

Keys to Success of IVUS-guided Rewiring

- Correct reading IVUS information
 - Based on histology
- Integration IVUS and Angiogram
 - Position and Direction
- Rewiring with Angiogram (Fluoroscopy)
- Confirm Wire Position by IVUS
- Patience

IVUS roles for Wire Cross

- ANTE-grade
 - Identifying entry point of CTO segment
 - Support wire penetration from false to true lumen
- RETRO-grade
 - Support for wire cross
 - in Retrograde Wire Cross
 - in Reverse CART
 - in Reverse CART with Stenting
- Review
 - Wire tracking route

IVUS Guided Identification of the Entry

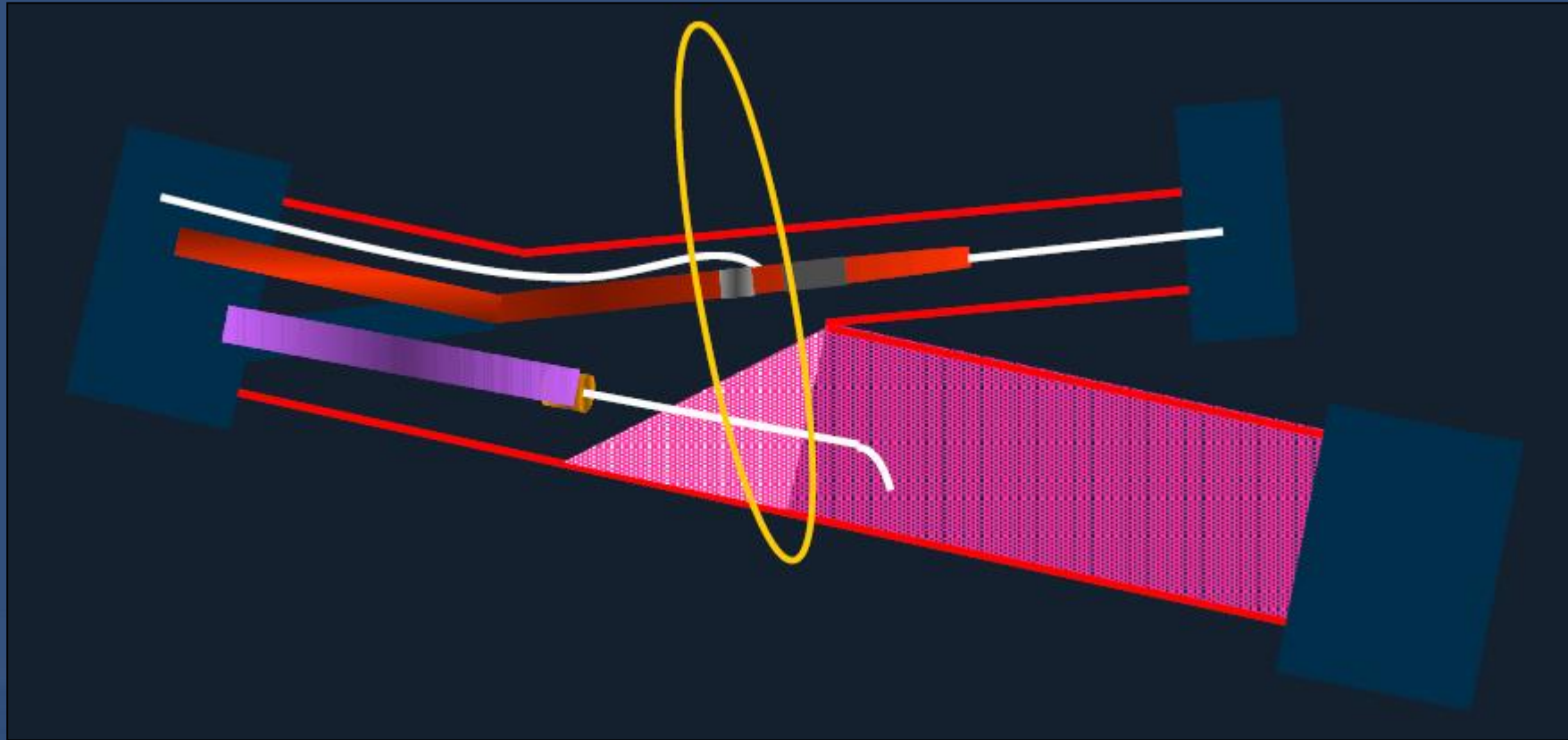

Evaluate the Position of Retrograde Wire

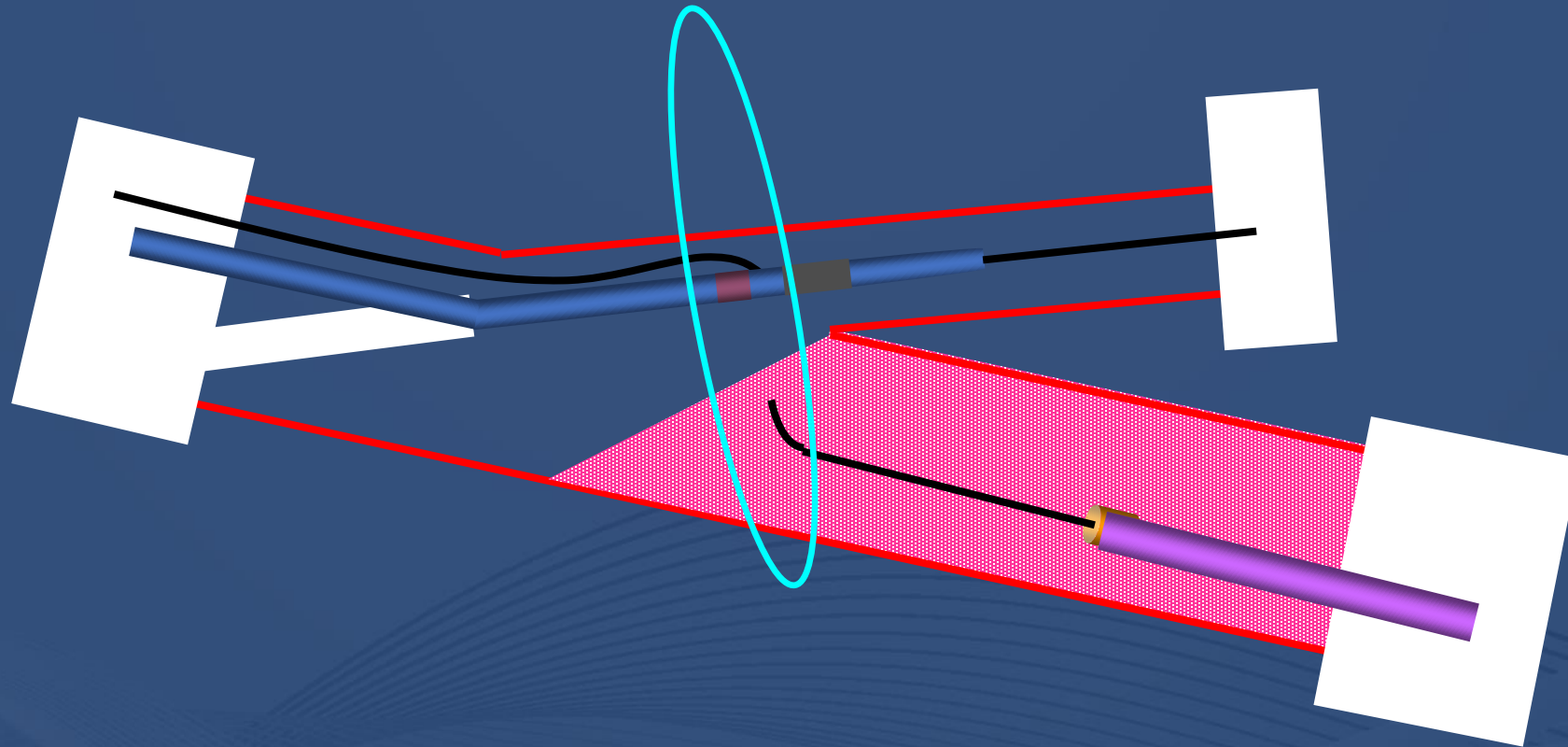

IVUS Guided Technique for Looking For the Entry

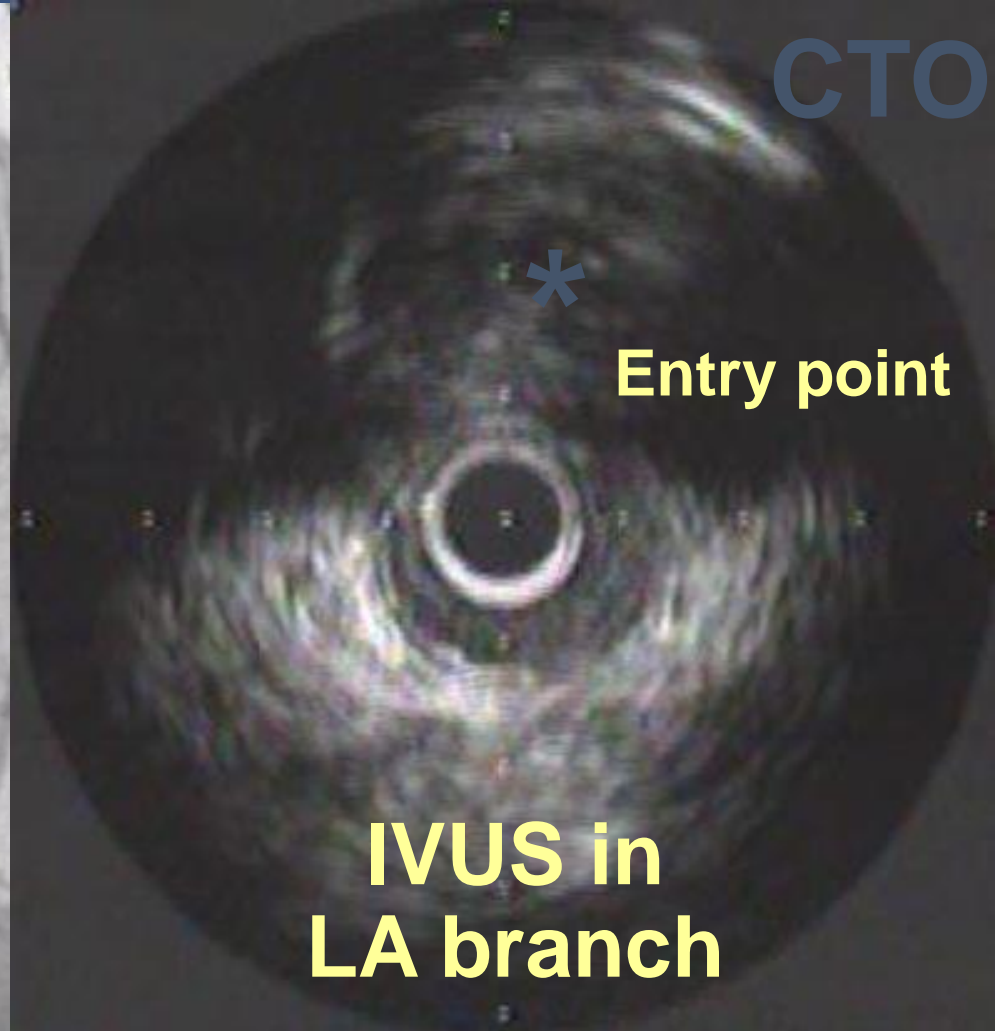
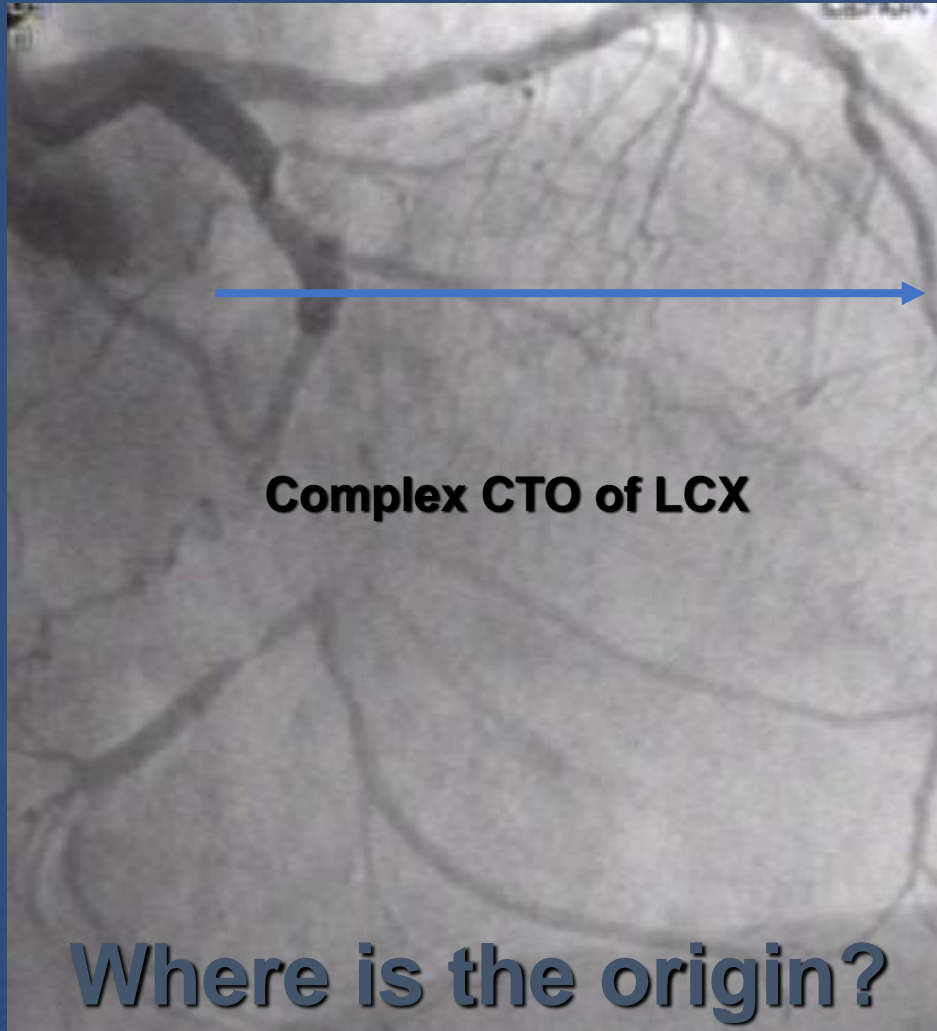

Serial IVUS Findings: CTO PCI with DES

40 CTOs systematically assessed

Distal vessel enlargement (positive remodeling) was seen

No variability with subintimal vs. luminal approach

Late stent malapposition seen in 42.5% (throughout segments)

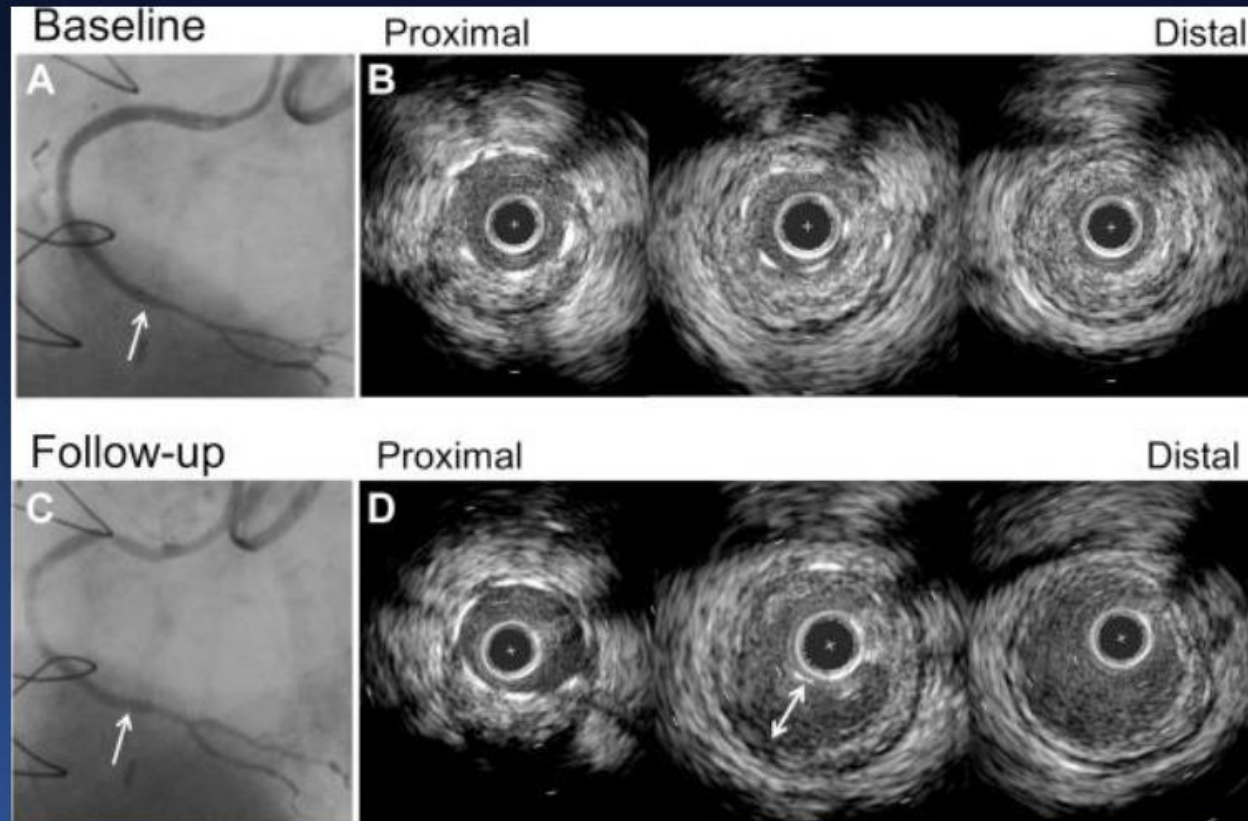

IVUS Guided Technique for Looking For the True Lumen

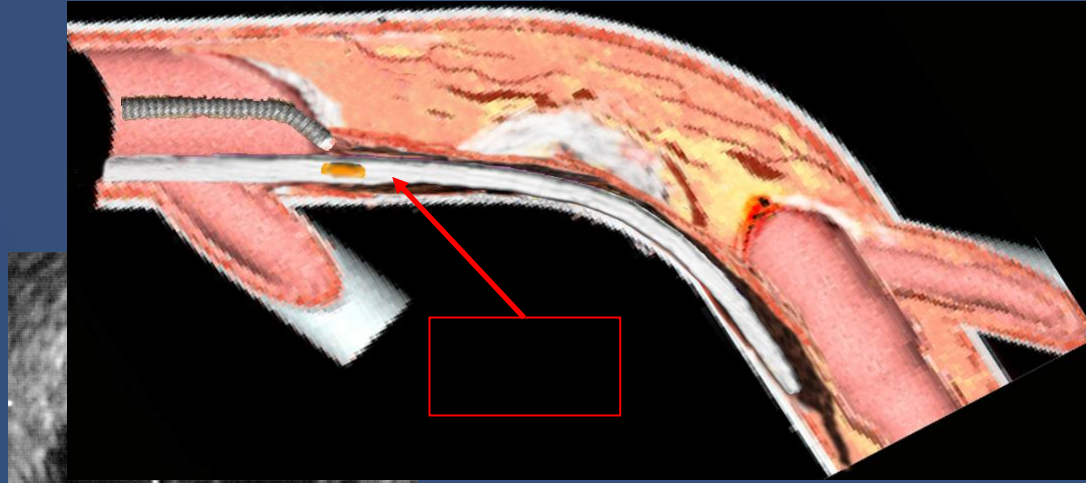

True lumen

Guide Wire

False lumen

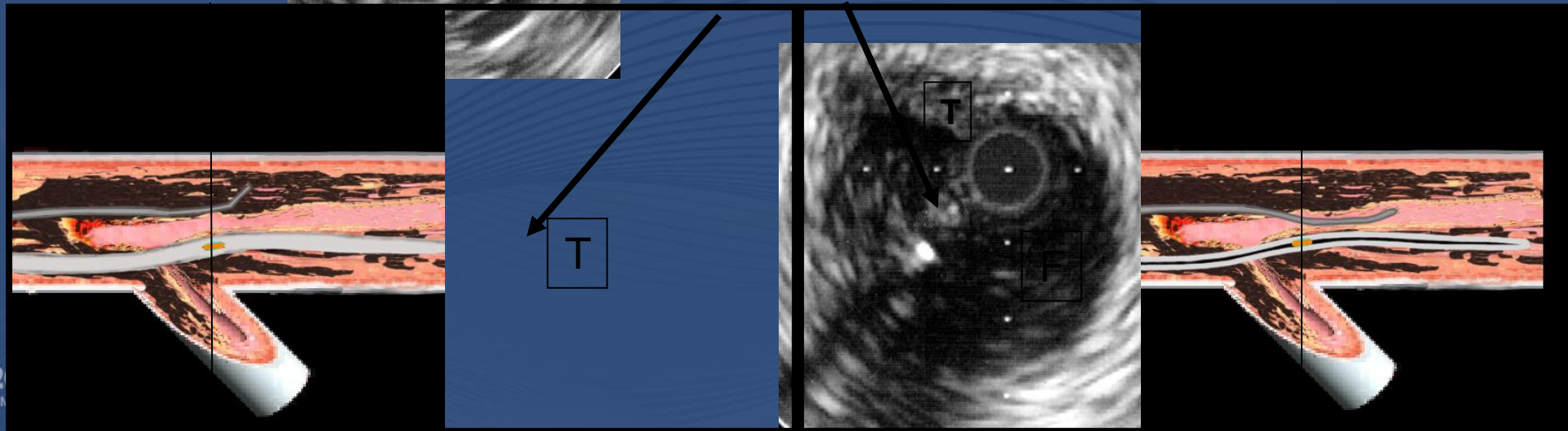

How to IVUS Guide Wire Crossing Technique

- Advance the guidewire into the subintimal space
- Subintimal space is enlarged with a 1.5mm balloon catheter along with the guidewire
- IVUS catheter is advanced into the subintimal space
- Stiff guidewire is advanced into the true lumen
- Wire manipulation under IVUS imaging

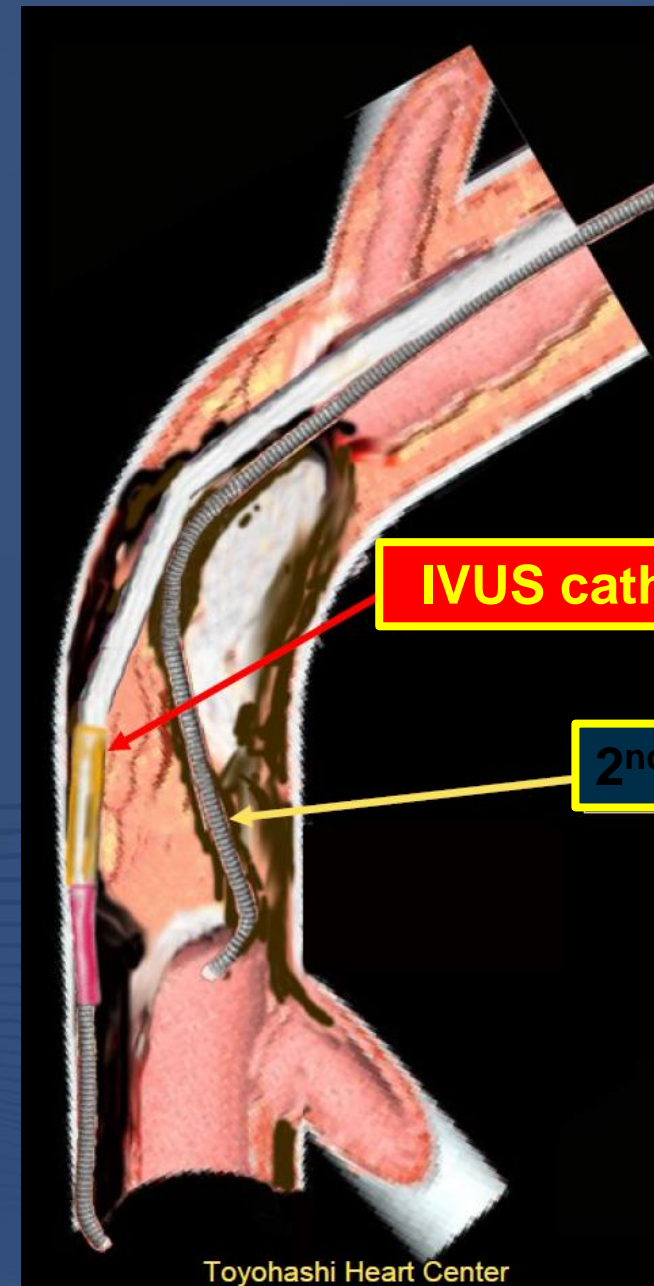

OCT-guided technique

Comparison of IVUS and OCT specifications

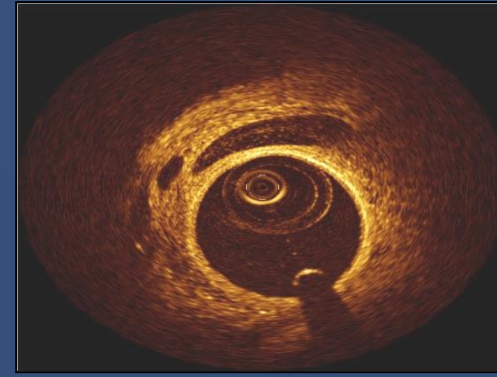
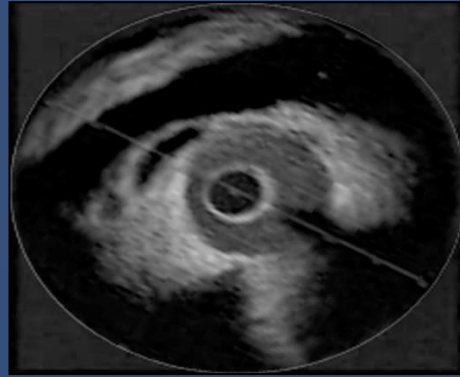

	IVUS	OCT
<i>Resolution</i>	(axial) 100 - 150 μ m (lateral) 150 - 300 μ m	10 - 15 μ m 25 - 40 μ m
<i>Frame rate</i>	30 frames/s	15 frames/s 30 frames/s (1/2 lateral resolution)
<i>Dynamic range</i>	40 - 60 dB	90 - 110 dB

DECISION-CTO

**Optimal Medical Therapy With or Without
Stenting For Coronary Chronic Total Occlusion**

Seung-Jung Park, MD., PhD.

Heart Institute, University of Ulsan College of Medicine
Asan Medical Center, Seoul, Korea

Background

- Benefits of successful CTO-PCI include reduced angina frequency and improvements in quality of life, left ventricular ejection fraction, or survival.
- However, CTO-PCI can lead to procedure-related complications. In addition, the evidence for CTO-PCI was obtained from observational studies, most of which compared successful and failed CTO-PCI without a control group receiving optimal medical treatment.

DECISION CTO Trial

Design

- DESIGN: a prospective, open-label, randomized trial
- OBJECTIVE: To compare the outcomes of OMT alone with PCI coupled with OMT in patients with CTO.
- PRINCIPAL INVESTIGATOR
Seung-Jung Park, MD, PhD,
Asan Medical Center, Seoul, Korea

Clinicaltrials.gov, Identifier: NCT01075051

Participating Centers (N=19)

Country	Site	Investigator
Korea	Asn Medical center	Seung-Jung Park
India	Ruby Hall Clinic	Shirish Hiremath
Korea	Keimyung University Dongsan Medical Center	Seung Ho Hur
Korea	Korea University Guro Hospital	Seung Un Rha
Indonesia	Medistra Hospital	Teguh Santoso
Korea	The Catholic University of Korea, Daejeon ST. Mary's Hospital	Sung-Ho Her
Korea	Chungnam National University Hospital, Daejeon	Si Wan Choi
Korea	Kangwon National University Hospital	Bong-Ki Lee
Korea	Soon Chun Hyang University Hospital Bucheon, Bucheon	Nae-Hee Lee
Korea	Kangbuk Samsung Medical Center, Seoul	Jong-Young Lee
Korea	Gangneung Asan Hospital, Gangneung	Sang-Sig Cheong,
Thailand	King Chulalongkorn Memorial Hospital	Wasan Udayachalerm
Korea	Dong-A University Hospital, Busan	Moo Hyun Kim
Korea	Chonnam National University Hospital, Gwangju	Young-Keun Ahn
Korea	Bundang Cha Medical Center, Bundang	Sang Wook Lim
Korea	Ulsan University Hospital, Ulsan	Sang-Gon Lee
Korea	Hangang Sacred Heart Hospital, Seoul	Min-Kyu Kim
Korea	Sam Anyang Hospital, Anyang	Il-Woo Suh
Taiwan	Shin Kong Hospital	Jun Jack Cheng

Major Inclusion Criteria

- Silent ischemia, stable angina, or ACS
- *De novo* CTO located in a proximal to mid epicardial coronary artery with a reference diameter of ≥ 2.5 mm
- CTO was defined as a coronary artery obstruction with TIMI flow grade 0 of at least three months' duration based on patient history.

Major Exclusion Criteria

- CTO located in
 - Distal coronary artery
 - 3 different vessel CTOs in any location
 - 2 proximal CTOs in separate coronary artery
 - left main segment
 - In-stent restenosis
 - Graft vessel
- LVEF < 30%
- Severe comorbidity

Original Power Calculation

Non-inferiority Design for Primary Endpoint

- Assumed primary event rate: 17% at 3 years
- A noninferiority margin : event rate ratio 0.7
- A one-sided type I error rate : 0.025
- Power : 80%
- Dropout rate: 5%
- Assumed sample size: 1,284 patients

Study Procedures (1)

- Patients who were assigned to PCIs underwent CTO-PCI using DES within 30 days after randomization using standard procedures.
- In cases of failed CTO-PCI, additional attempts were allowed within 30 days after the index procedure.
- The use of specialized devices or techniques, and the choice of drug-eluting stent type were left to the operator's discretion.

Study Procedures (2)

- Revascularization for all significant non-CTO lesions within a vessel diameter of ≥ 2.5 mm for patients with multi-vessel coronary artery disease was recommended.
- Patients were prescribed guideline derived optimal medical treatment including aspirin, P2Y12 receptor inhibitors (>12months in case of PCI), beta-blocker, CCB, nitrate, ACEi/ARB, and statin.
- Blood pressure and diabetic control, smoking cessation, weight control, and regular exercise were recommended.

Premature Termination of Trial

- Because enrollment was slower than anticipated, enrollment was stopped in September 2016 as recommended by the data and safety monitoring board by which time 834 patients had been enrolled.
- The sponsor and study leadership were unaware of study results at the time of this decision.

Statistical Analysis

- All analyses were performed according to the intention-to-treat principle. Further sensitivity analyses were performed in the per-protocol and as-treated population.
- Hazard ratios (HRs) and 95% confidence intervals (CIs) were estimated using Cox proportional hazard models, with robust standard errors that accounted for clustering effect of stratified randomization.
- Noninferiority test using the Z-test with 95% CI of difference in the 3-year event rate.
- Survival curves were estimated using Cox model and the Kaplan-Meier method
- For quality of life analysis, we assumed the missing values were missing at random, and compared mean values of two groups using Student's t-test at specific time points.
- All P-values and CIs were two-sided. SAS software version 9.3 was used for all statistical analyses.

Primary End Point

At 3 year, a composite of

- Death from any cause
- Myocardial infarction
 - Periprocedural MI: CK-MB > 5 times UNL
 - Spontaneous MI: any cardiac enzyme elevation
- Stroke
- Any repeat revascularization

Original Power Calculation

Non-inferiority Design for Primary Endpoint

- Assumed primary event rate: 17% at 3 years
- A noninferiority margin : event rate ratio 0.7
- A one-sided type I error rate : 0.025
- Power : 80%
- Dropout rate: 5%
- Assumed sample size: 1,284 patients

Premature Termination of Trial

- Because enrollment was slower than anticipated, enrollment was stopped in September 2016 as recommended by the data and safety monitoring board by which time 834 patients had been enrolled.
- The sponsor and study leadership were unaware of study results at the time of this decision.

Study Flow

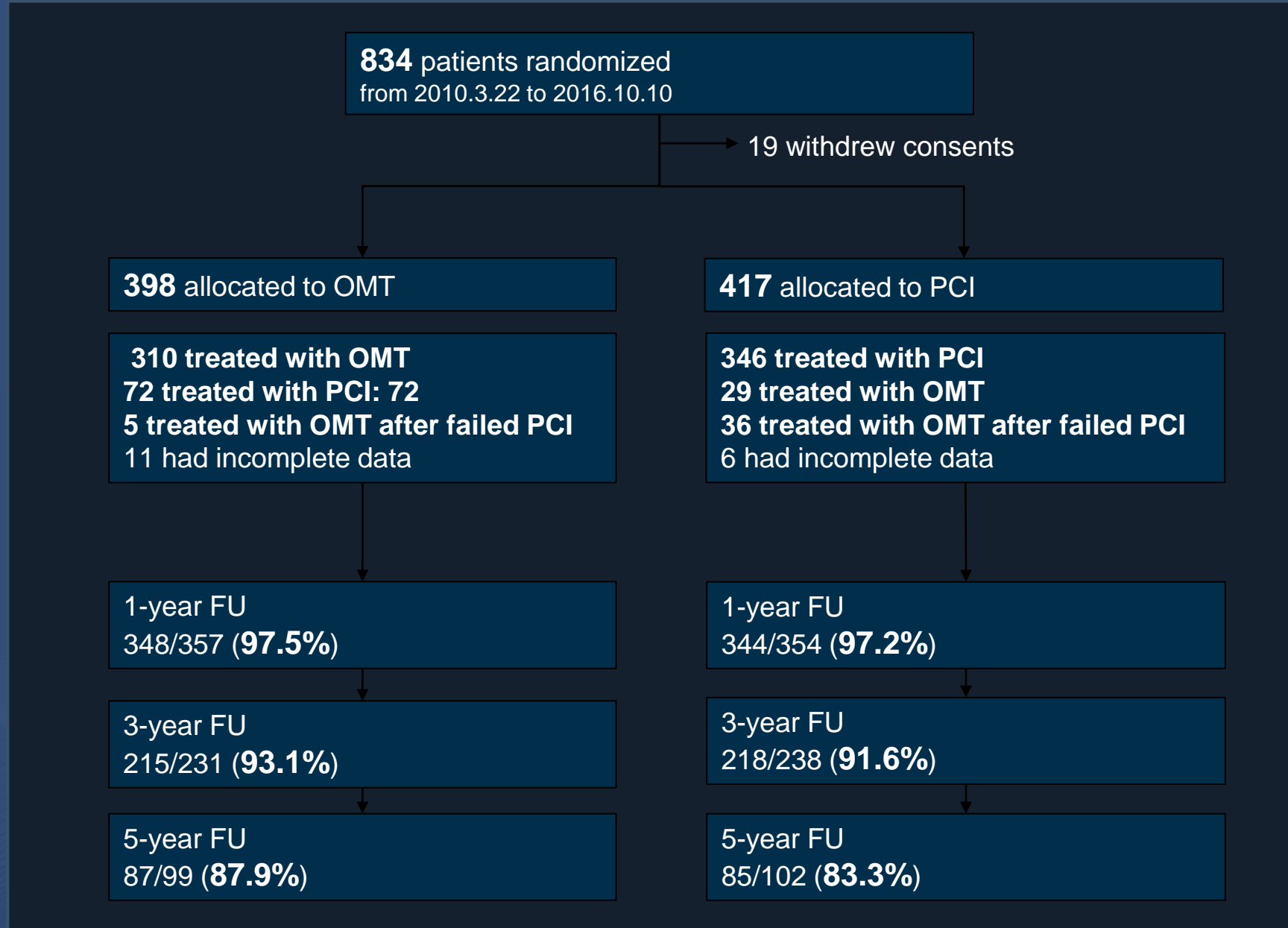

Study Flow

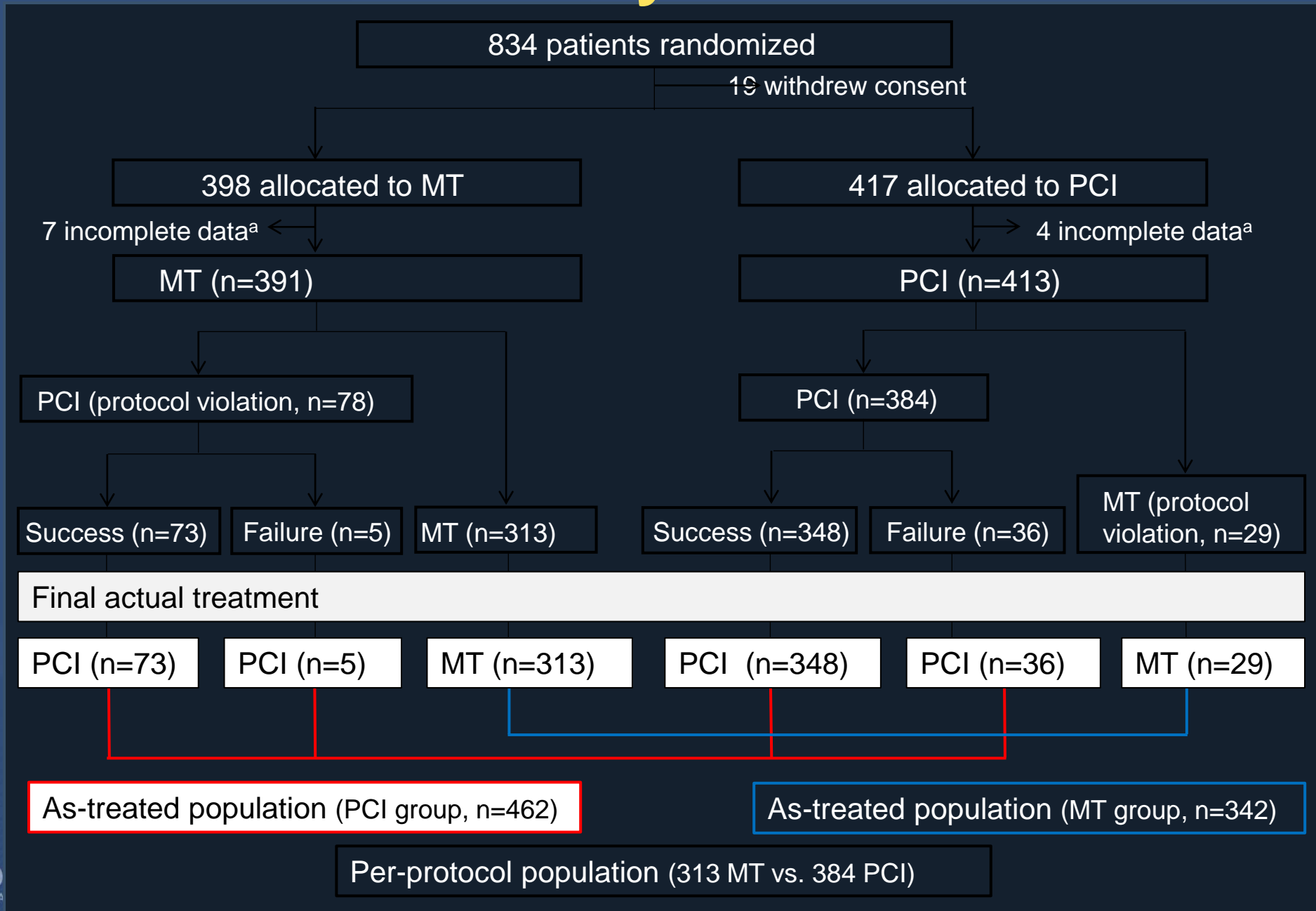

Statistical Analysis

- All analyses were performed according to the intention-to-treat principle. Further sensitivity analyses were performed in the per-protocol and as-treated population.
- Hazard ratios (HRs) and 95% confidence intervals (CIs) were estimated using Cox proportional hazard models, with robust standard errors that accounted for clustering effect of stratified randomization.
- Noninferiority test using the Z-test with 95% CI of difference in the 3-year event rate.
- Survival curves were estimated using Cox model and the Kaplan-Meier method
- For quality of life analysis, we assumed the missing values were missing at random, and compared mean values of two groups using Student's t-test at specific time points.
- All P-values and CIs were two-sided. SAS software version 9.3 was used for all statistical analyses.

Baseline Characteristics

ITT Population

	No-CTO PCI (N=398)	CTO-PCI (N=417)	P value
Age (years)	62.9±9.9	62.2±10.2	0.32
Male sex	319 (81.6%)	344 (83.3%)	0.59
BMI, kg/m ²	25.5±3.3	25.6±3.5	0.59
Hypertension	238 (60.9%)	262 (63.4%)	0.50
Diabetes mellitus	134 (34.3%)	132 (32.0%)	0.54
Hypercholesterolemia	217 (55.5%)	249 (60.3%)	0.19
Current smoker	102 (26.1%)	125 (30.3%)	0.22
Previous PCI	75 (19.2%)	64 (15.5%)	0.20
Previous MI	34 (8.7%)	45 (10.9%)	0.35
Previous CABG	5 (1.3%)	4 (1.0%)	0.93
Renal dysfunction	5 (1.3%)	6 (1.5%)	0.99
LVEF, %	57.6±9.1%	57.3±9.8%	0.68

Baseline Characteristics

ITT Population

	No CTO-PCI (N=398)	CTO-PCI (N=417)	P value
Clinical presentation			0.79
Stable angina	290 (75.0%)	300 (72.7%)	
Unstable angina	76 (19.4%)	84 (20.3%)	
AMI	22 (5.6%)	29 (7.0%)	
Location of CTO			0.67
LAD	163 (41.7%)	185 (44.8%)	
LCX	42 (10.7%)	42 (10.2%)	
RCA	186 (47.6%)	186 (45.0%)	
Multivessel disease	288 (73.6%)	302 (73.2%)	0.83
SYNTAX score	20.8±9.5	20.8±9.2	0.99
J-CTO score	2.2±1.2	2.1±1.2	0.16
Number of total stents	2.0±1.4	2.4±1.3	<0.001
Total stent length, mm	53.6±39.4	71.2±40.5	<0.001

Lesion and Procedural Characteristics

ITT Population

Variable	CTO lesion			Non-CTO lesion		
	MT strategy (n=398)	PCI strategy (n=417)	P	MT strategy (n=398)	PCI strategy (n=417)	P
Number of lesion ^b						0.59
0				97 (25.0)	107 (26.2)	
1		Not applicable		127 (32.7)	145 (35.5)	

	MT Strategy	PCI Strategy	P value
CR (non-CTO vs.)	302 (77.2%)	325 (78.7%)	0.67
Residual SS (non-CTO vs.)	3.7 ± 5.4	4.0 ± 5.9	0.42

Total stent length, mm	53.6 ± 39.4	71.3 ± 40.5	≤0.001	44.2 ± 28.0	41.1 ± 25.9	0.26
Stent diameter, mm	3.1 ± 0.4	3.1 ± 0.3	0.18	3.2 ± 0.4	3.2 ± 0.4	0.88
Stents			0.31			0.14
Early generation DES	4 (5.5)	13 (3.7)		10 (5.2)	7 (3.3)	
Newer generation DES	69 (94.5)	335 (96.3)		18 (94.8)	206 (96.7)	
IVUS use	7 (9.6)	203 (58.3)		108 (56.5)	114 (53.8)	0.58
Fluoroscopy time, minutes	37.2 ± 35.7	42.0 ± 34.0	0.09			
Total contrast amount, ml	337 ± 177	341 ± 157	0.78			

CTO PCI Characteristics

Attempted PCI	N=459
CTO PCI success	418 (91.1%)
Retrograde approach	113 (24.6%)
Lesion passaged wire	
Low penetration force wire	117/418 (28.0%)
Intermediate to high penetration force wire	301/418 (72.0%)
CTO technique	
Single wire technique only	309/418 (73.9%)
Parallel wire technique	72/418 (17.2%)
IVUS-guided wiring	25/418 (6.0%)
CART technique	55/418 (13.2%)
Additional back-up support	
Corsair	91/418 (21.8%)
Microcatheter other than Corsair	230/418 (55.0%)
Over-the-wire balloon	6/418 (1.4%)

Noninferiority Test for Primary End Point at 3-Year

ITT Population

Estimated 3-year Event Rate OMT: 19.6% PCI: 20.6%

Prespecified non-inferiority margin: 0.7

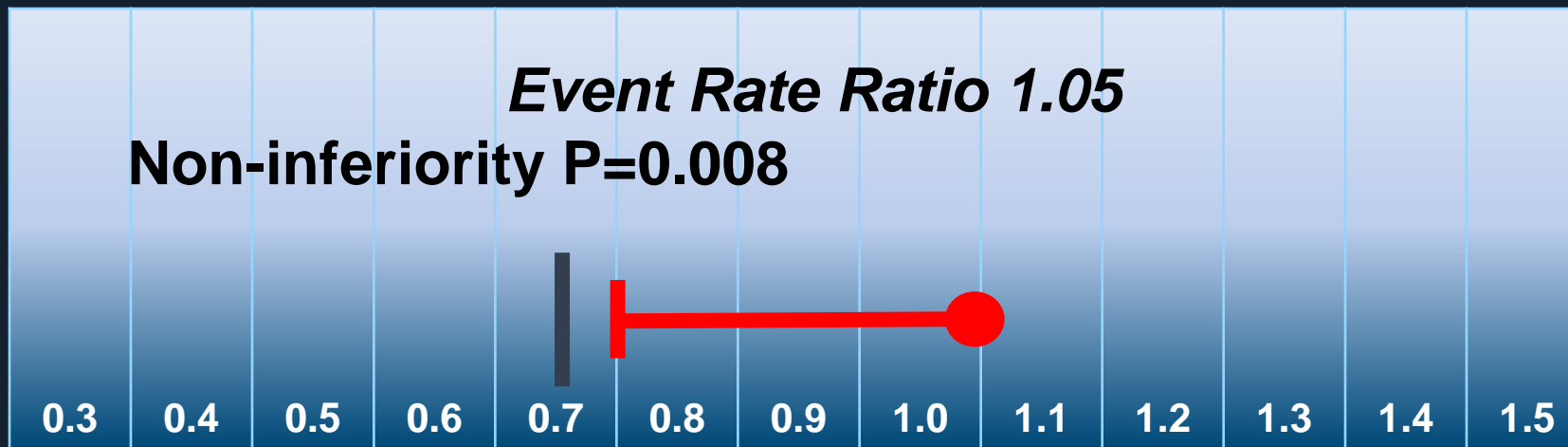

Event Rate Ratio of 3-year MACE rate (PCI/OMT)

Lower 1-sided 97.5% CI

Primary End Point

(Death, MI, Stroke, Any Revascularization)

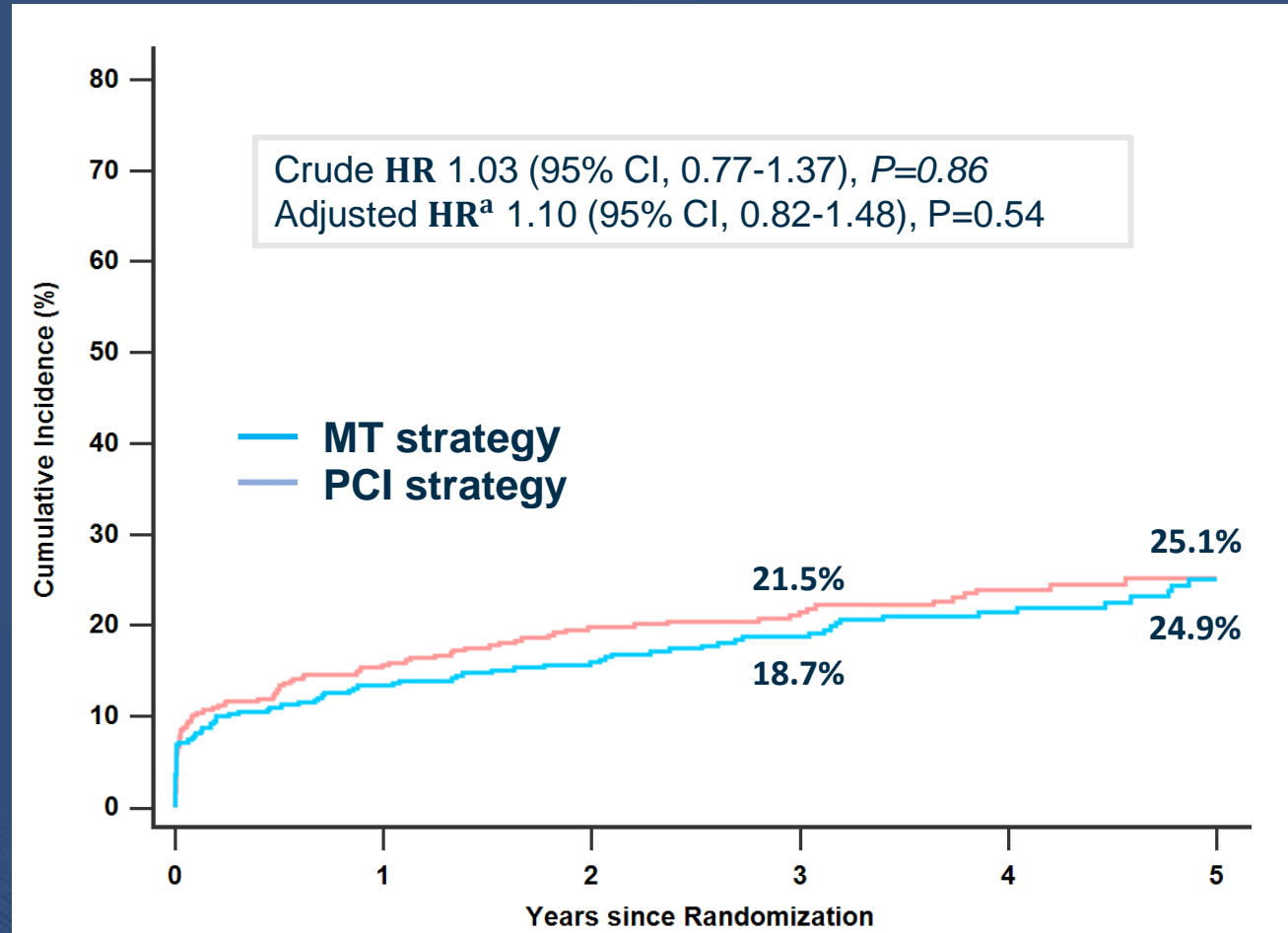

	0	1	2	3	4	5
Medical therapy	398	324	287	229	169	107
PCI	417	330	268	221	159	104

^aAdjusted for age, BMI, hypercholesterolemia, previous stroke, renal dysfunction, atrial fibrillation, clinical presentation, location of CTO, number of diseased vessels, and stratifying covariates.

Clinical Endpoints

	MT Strategy (n=398)	PCI Strategy (n=417)	Crude HR (95% CI)	P value	Adjusted HR* (95% CI)	P value
Primary endpoint Death, MI, stroke, or any revascularization	89 (22.4)	93 (20.3)	1.03 (0.77-1.37)	0.86	1.10 (0.69-1.24)	0.54
Secondary endpoints						
Death	21 (5.3)	15 (3.6)	0.70 (0.36-1.37)	0.30	0.85 (0.42-1.72)	0.65
Cardiac cause	14 (3.5)	8 (1.9)	0.56 (0.24-1.34)	0.19	0.63 (0.24-1.63)	0.34
Noncardiac cause	7 (1.8)	7 (1.7)	0.99 (0.35-2.82)	0.99	1.16 (0.36-3.77)	0.80
Myocardial infarction	34 (8.5)	47 (11.3)	1.31 (0.85-2.04)	0.23	1.42 (0.90-2.23)	0.13
Periprocedural MI	30 (7.5)	41 (9.8)	1.30 (0.81-2.07)	0.29	1.36 (0.84-2.20)	0.22
Spontaneous MI	7 (1.8)	7 (1.7)	0.83 (0.28-2.48)	0.74	0.87 (0.27-2.77)	0.82
Stroke	10 (2.5)	6 (1.4)	0.57 (0.21-1.58)	0.28	0.97 (0.32-2.96)	0.96
Any revascularization	42 (10.6)	46 (11.0)	1.08 (0.71-1.65)	0.71	1.09 (0.71-1.68)	0.70
CTO vessel	30 (7.5)	33 (7.9)	1.01 (0.67-1.79)	0.73	1.06 (0.64-1.76)	0.81
Non-CTO vessel	23 (5.8)	29 (7.0)	1.24 (0.72-2.14)	0.44	1.31 (0.74-2.32)	0.36
Death, MI, or stroke	61 (15.3)	66 (15.8)	1.07 (0.75-1.51)	0.72	1.26 (0.88-1.80)	0.21
Cardiac death, MI, stroke, or any revascularization	82 (20.6)	86 (20.6)	1.02 (0.76-1.39)	0.88	1.08 (0.80-1.48)	0.61
Death, spontaneous MI, stroke, or any revascularization	69 (17.3)	64 (15.3)	0.91 (0.65-1.30)	0.59	1.01 (0.71-1.42)	0.98

*Adjusted for age, BMI, hypercholesterolemia, previous stroke, renal dysfunction, atrial fibrillation, clinical presentation, location of CTO, number of diseased vessels, and stratifying covariates.

Primary End Point

(Death, MI, Stroke, Any Revascularization)

Per-protocol population

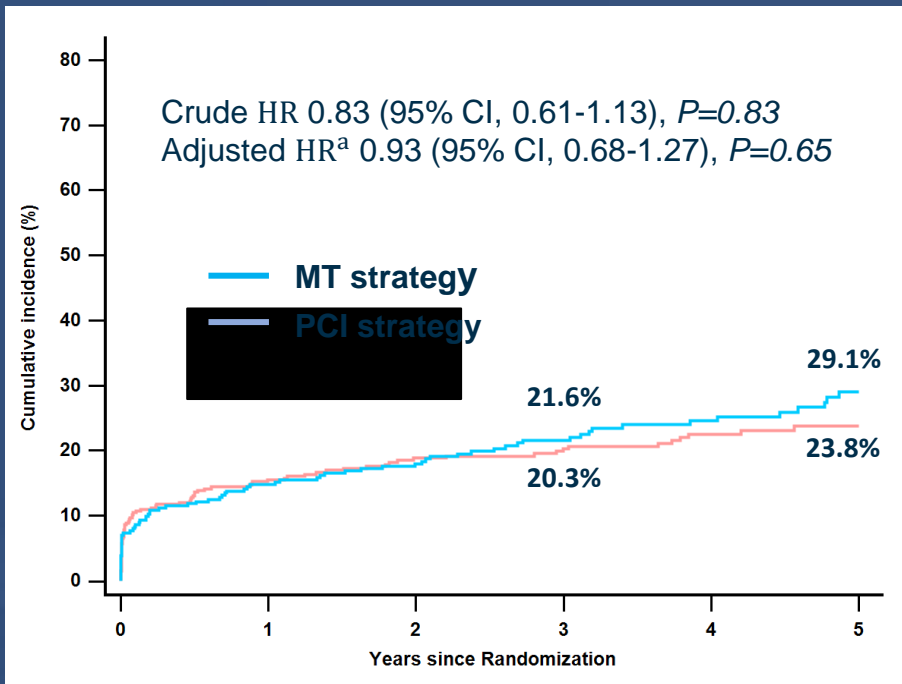

As-treated population

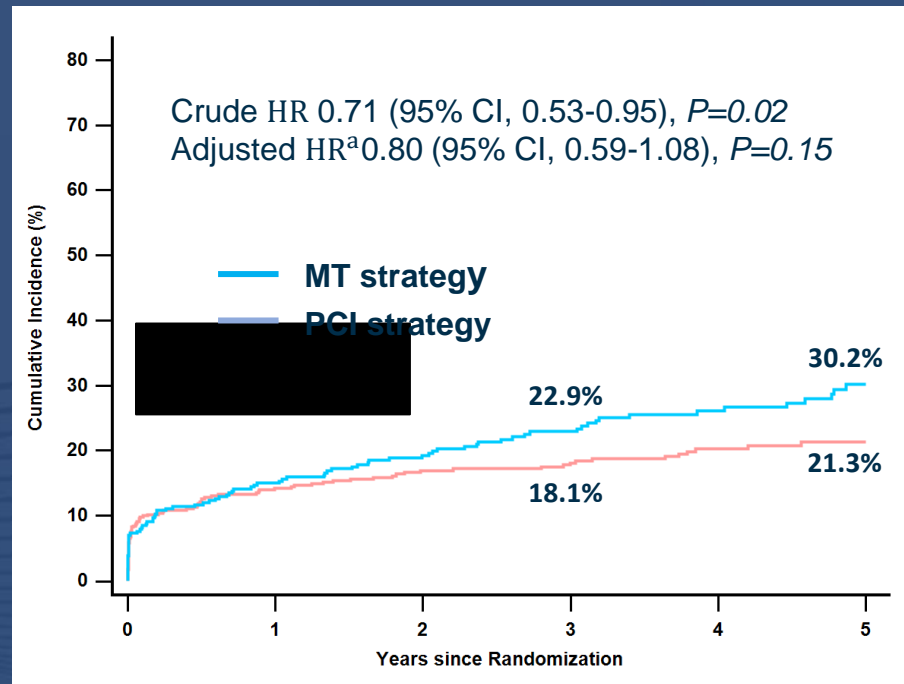

MT	313	257	224	172	125	79
PCI	384	306	254	210	152	98

MT	342	281	239	184	134	86
PCI	462	375	318	268	197	127

Death from any cause

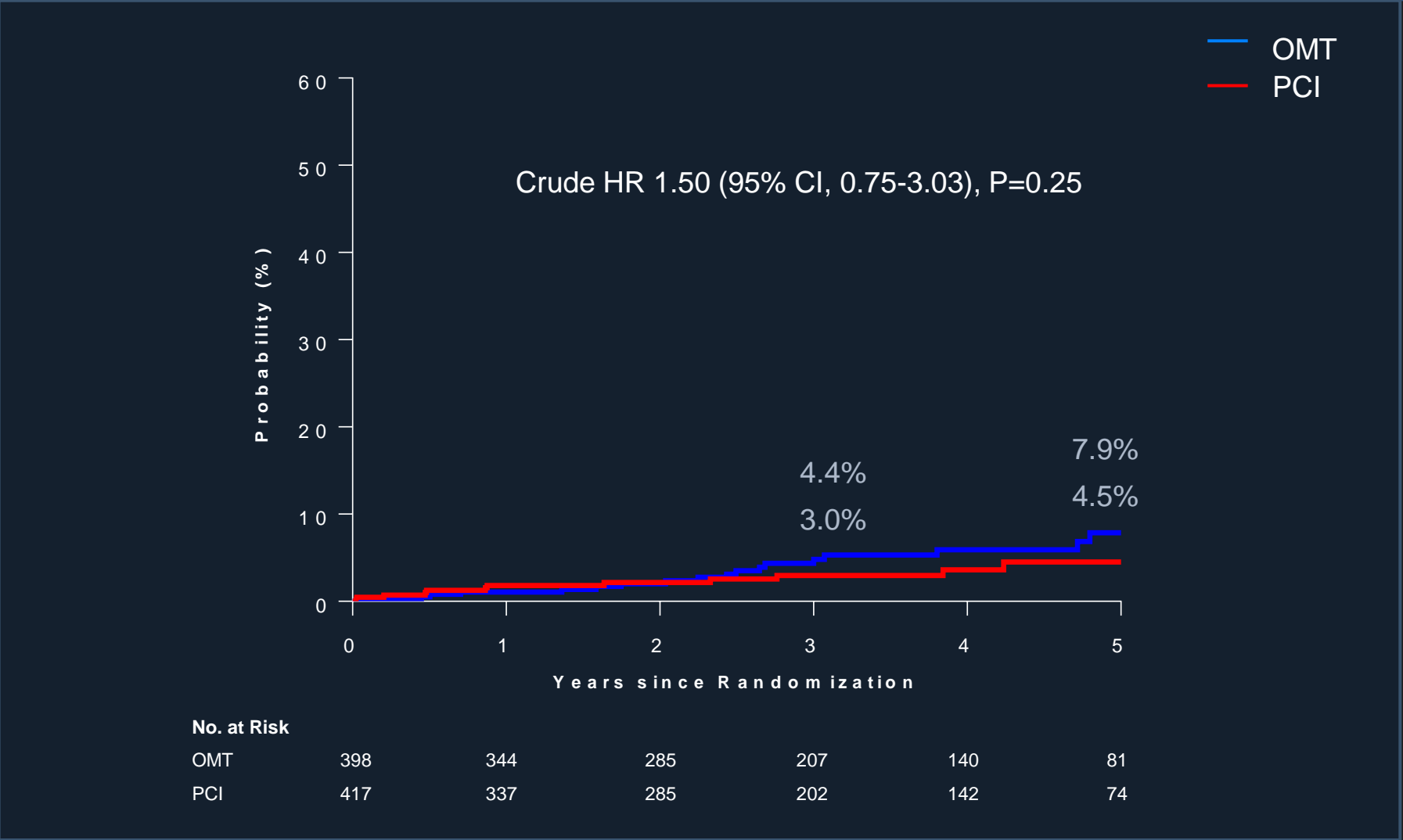

Death from any cause

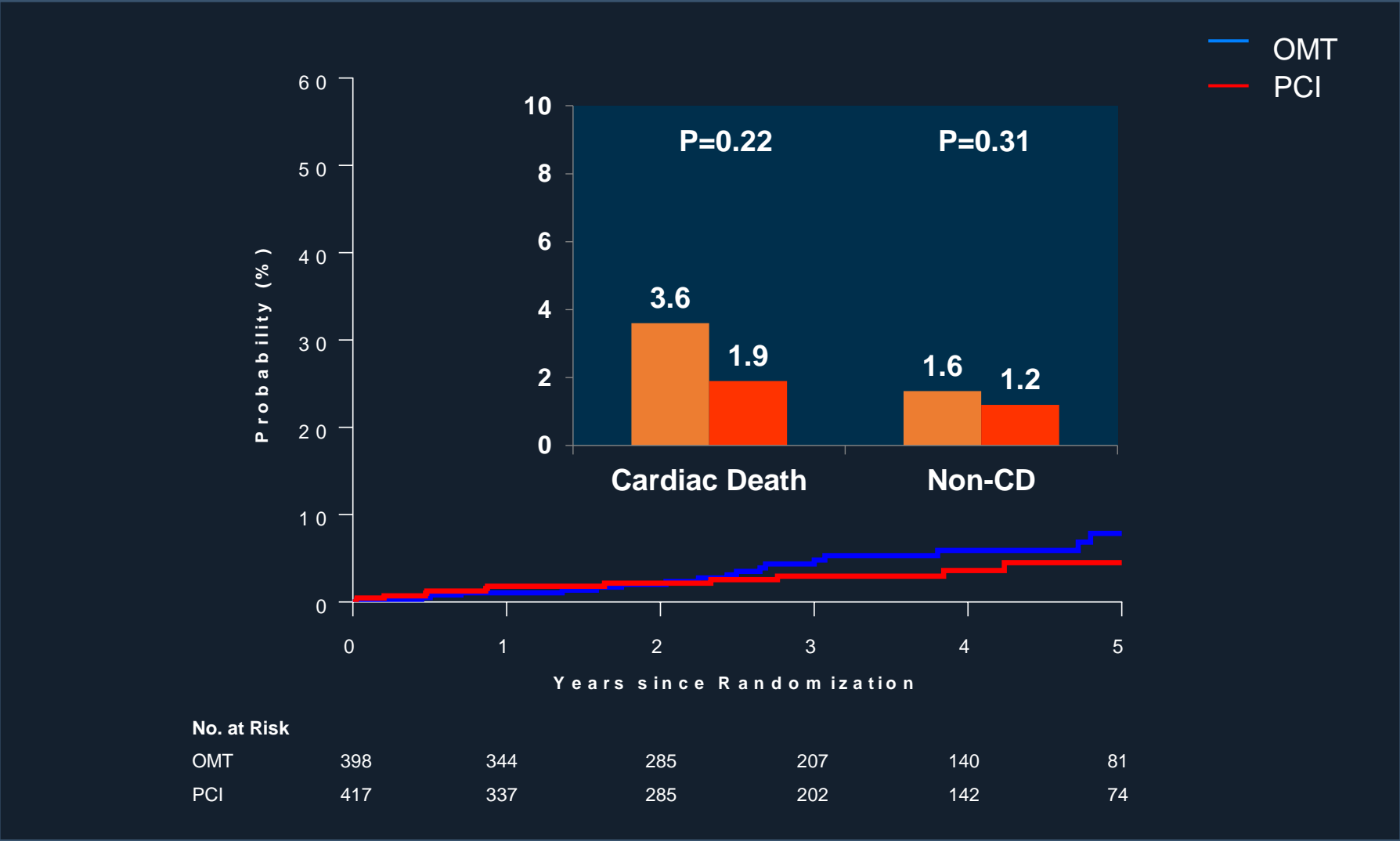

Myocardial Infarction

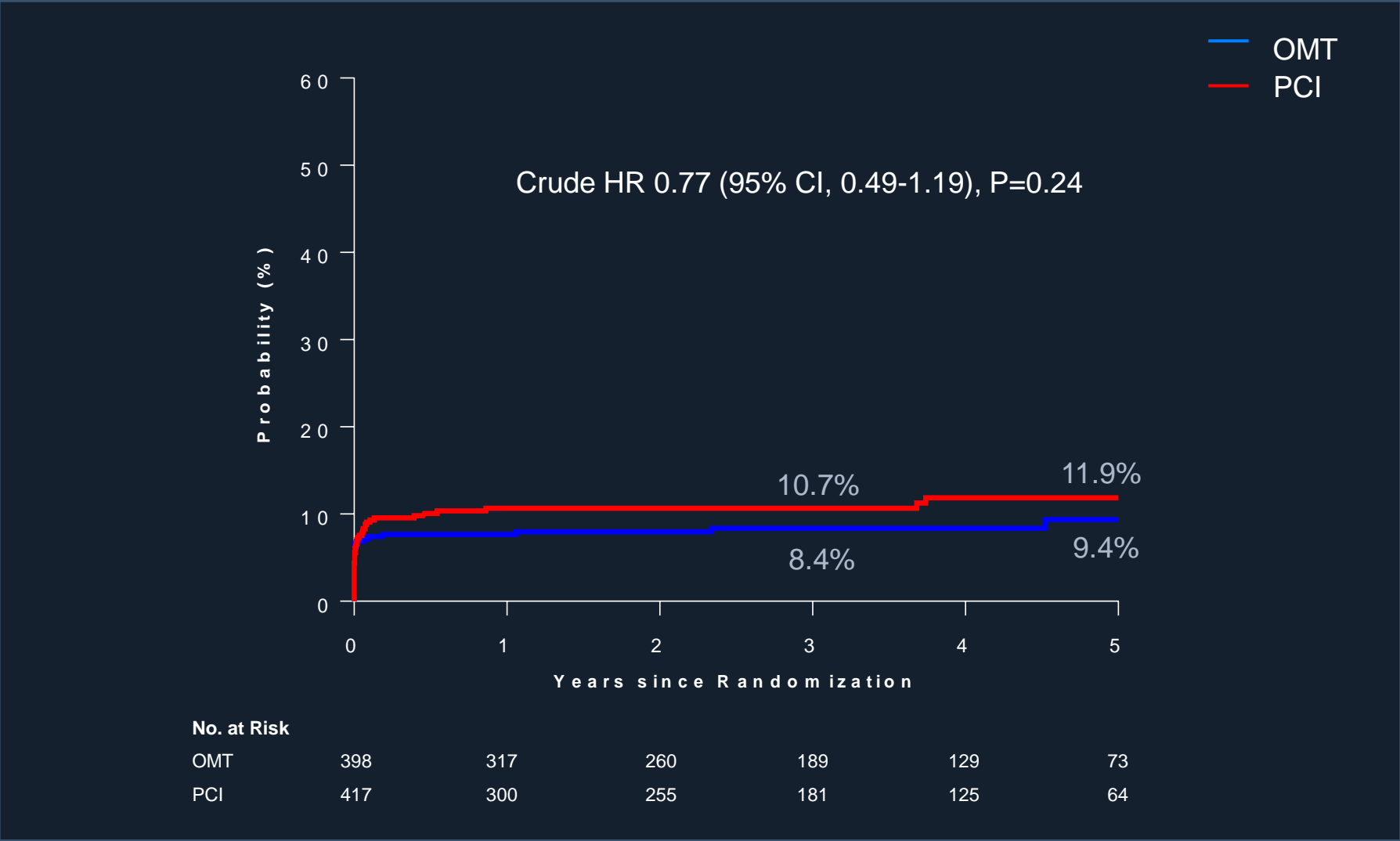

Myocardial Infarction

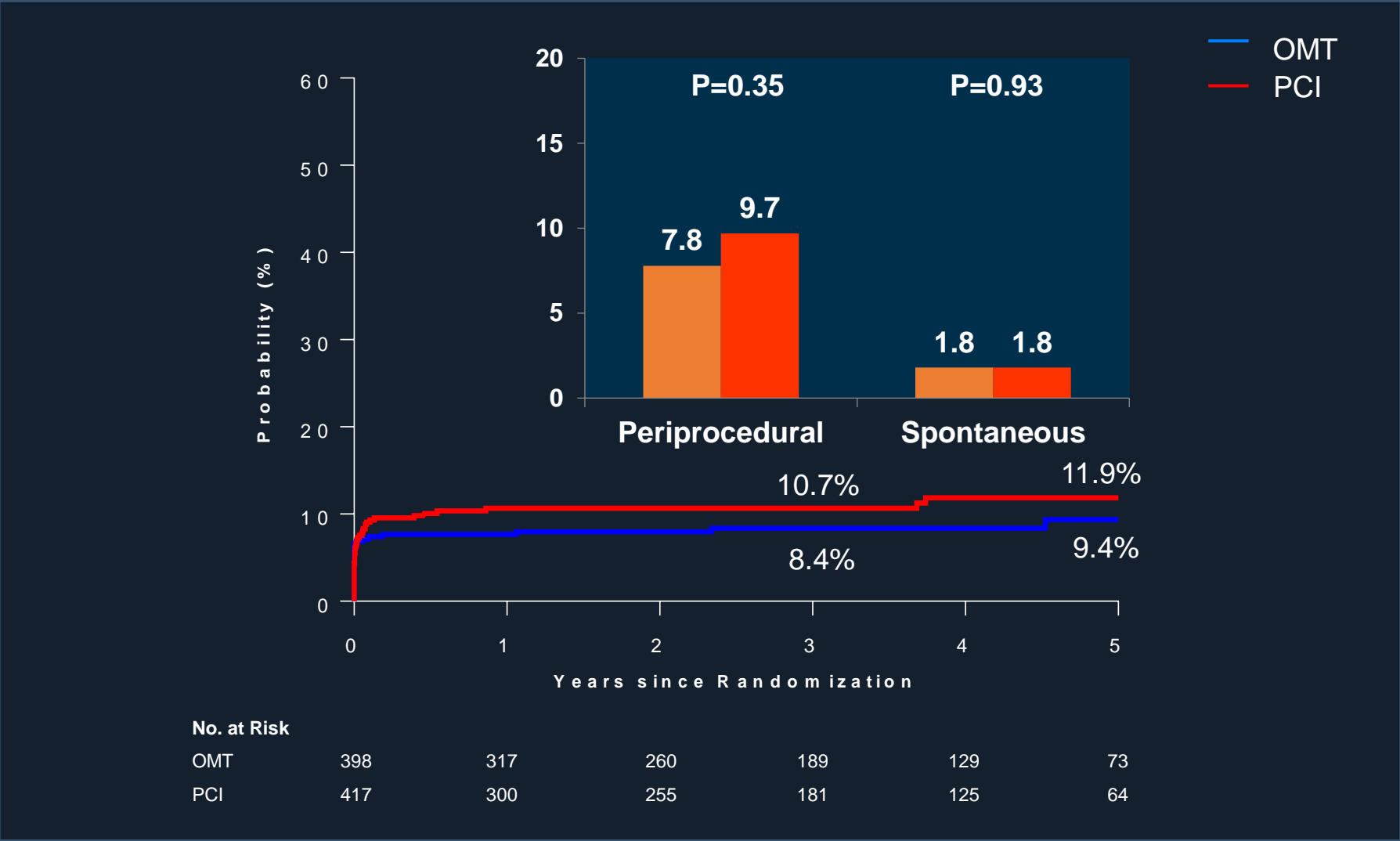

Stroke

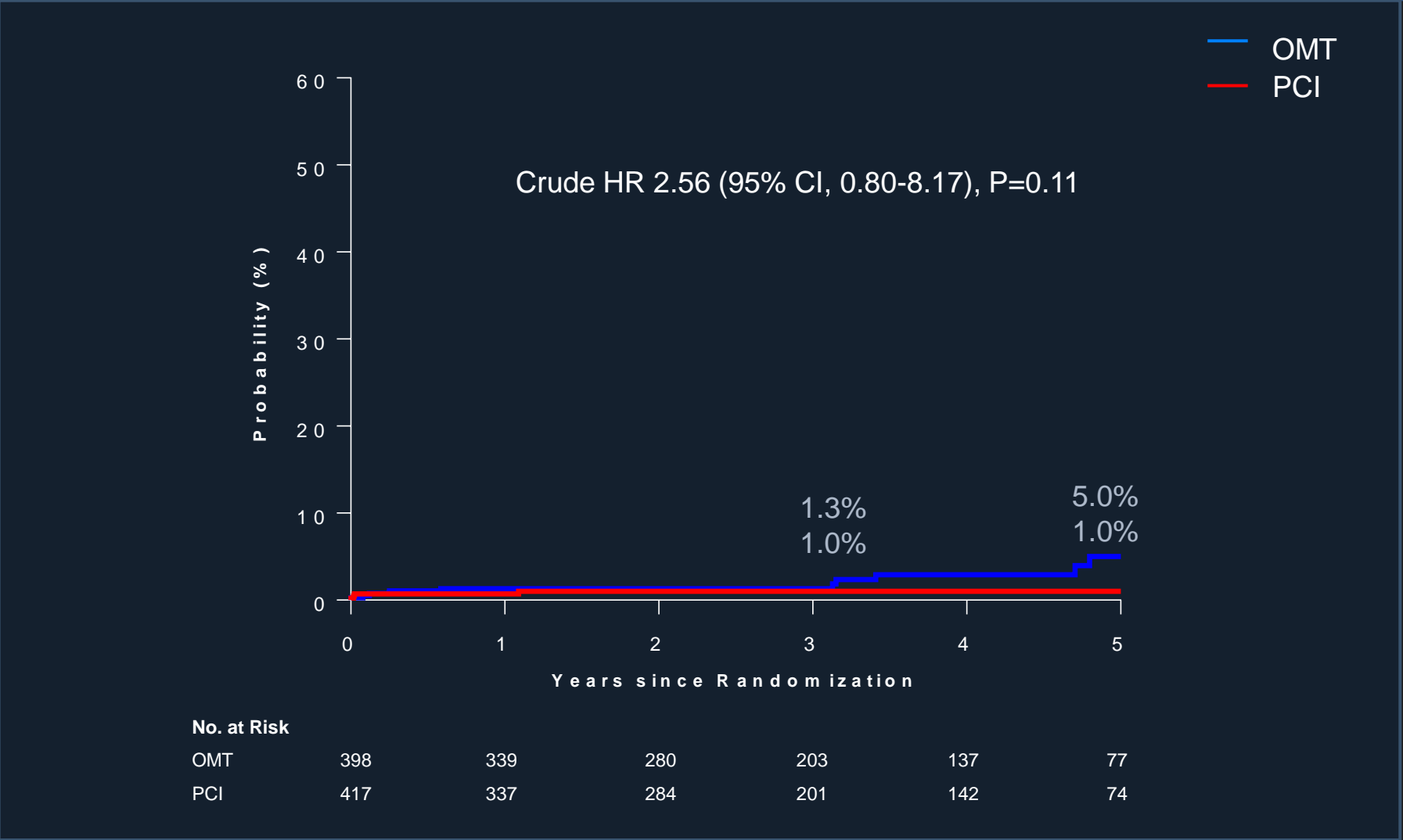

Repeat Revascularization

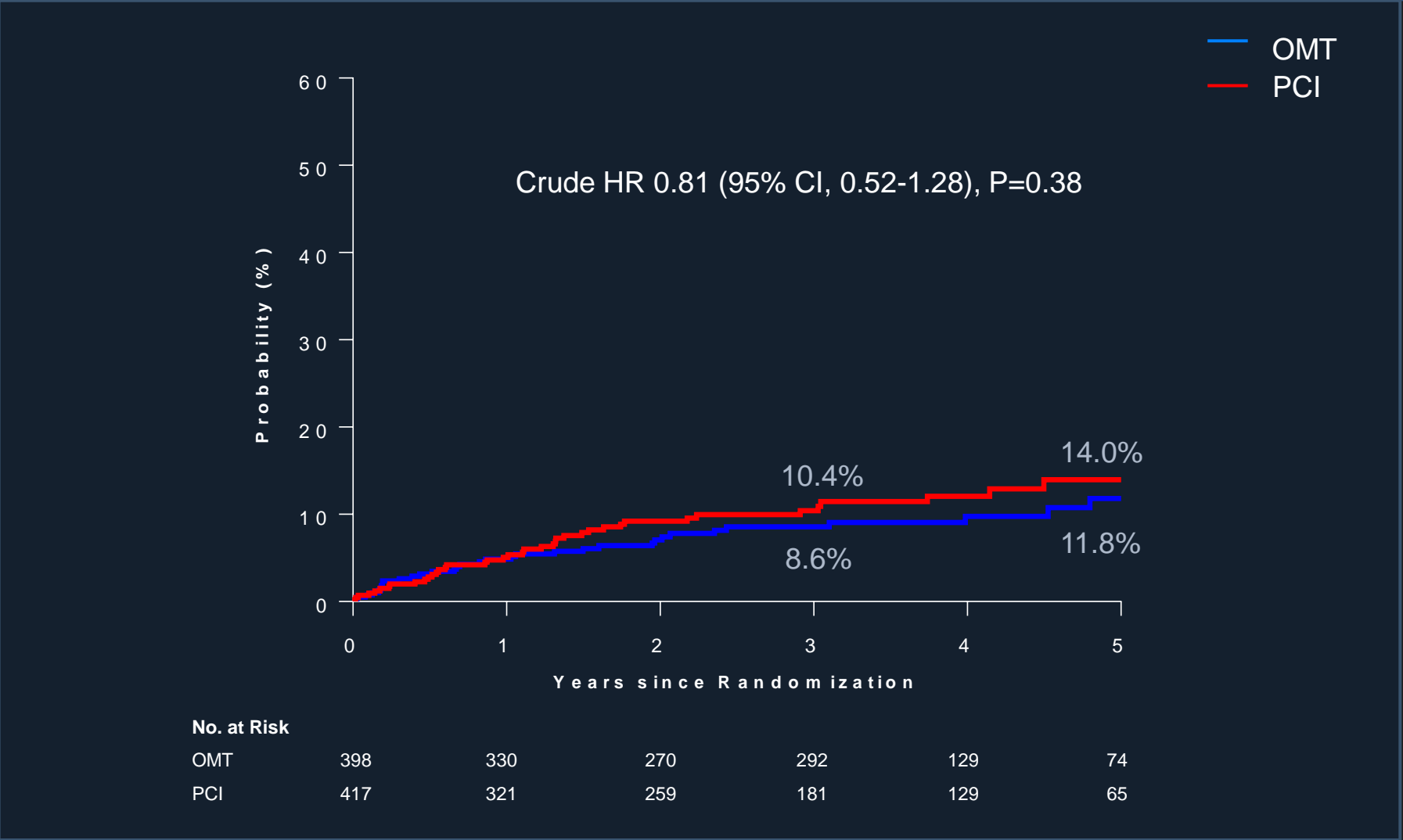

Repeat Revascularization

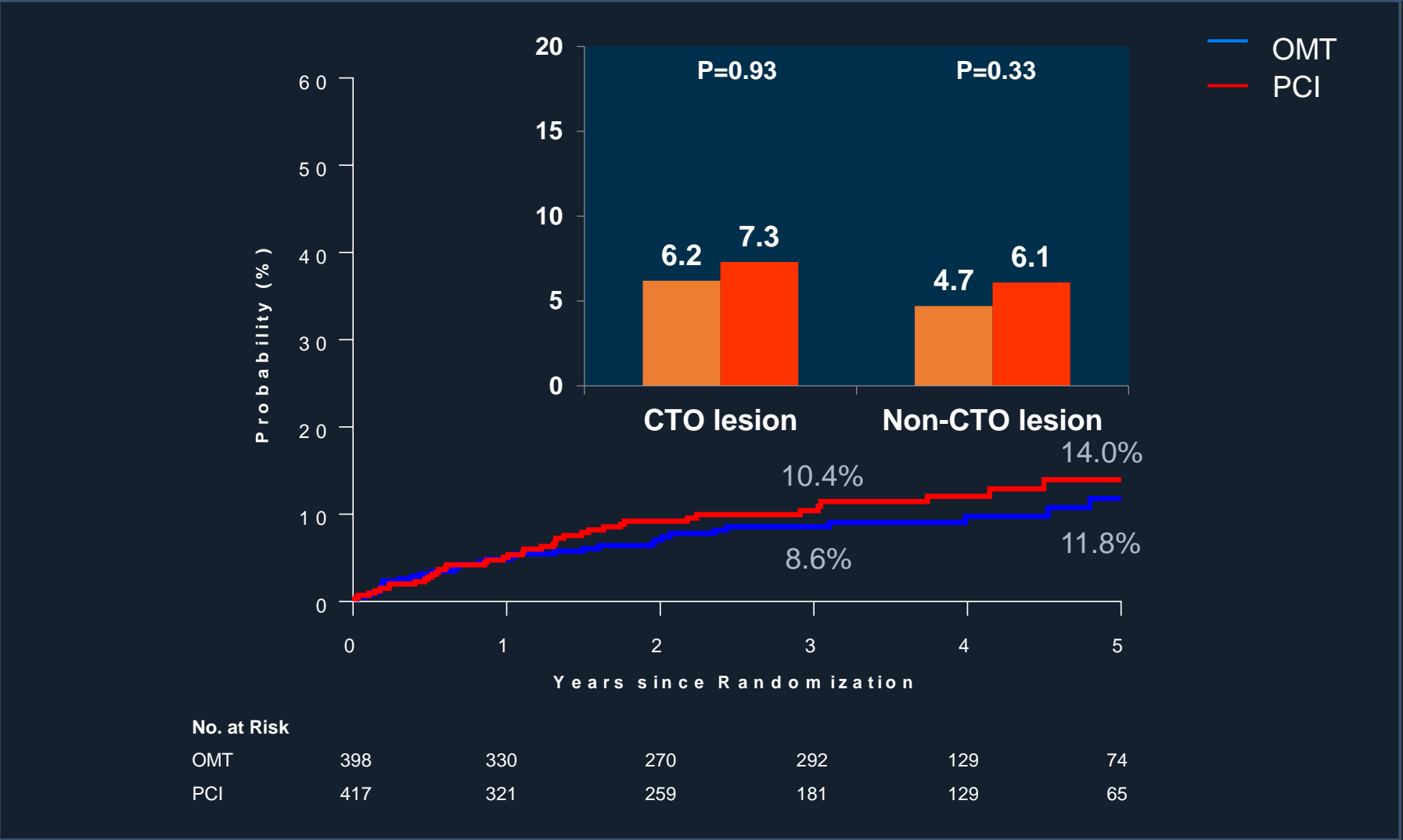

QOL Measure Scores

Within group changes from baseline to 1 month

PCI strategy

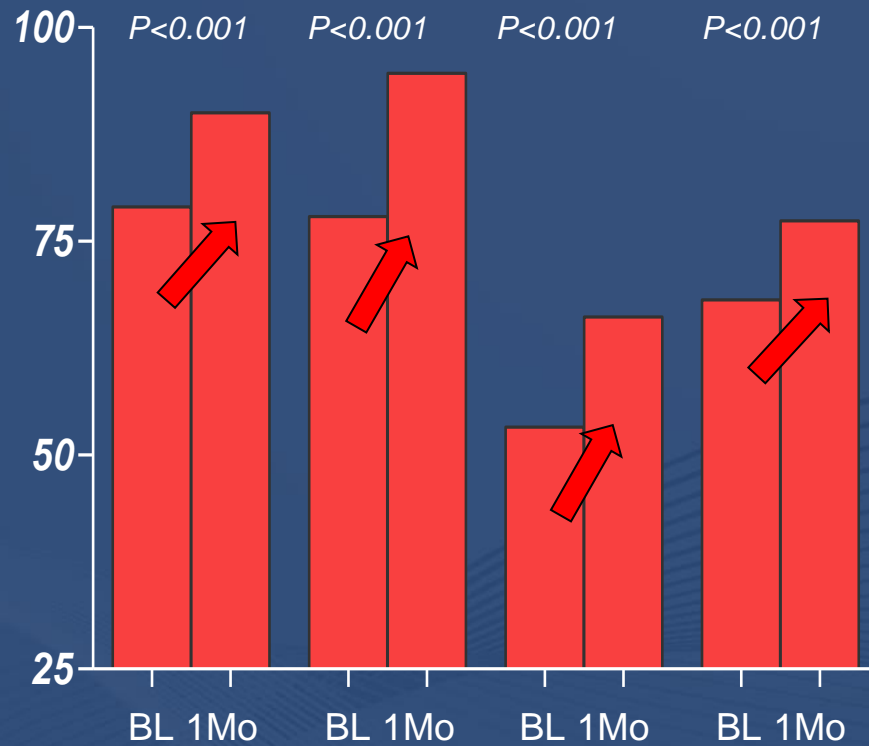

Physical Limitation
Angina Frequency
Quality of Life
EQ-5D VAS

MT strategy

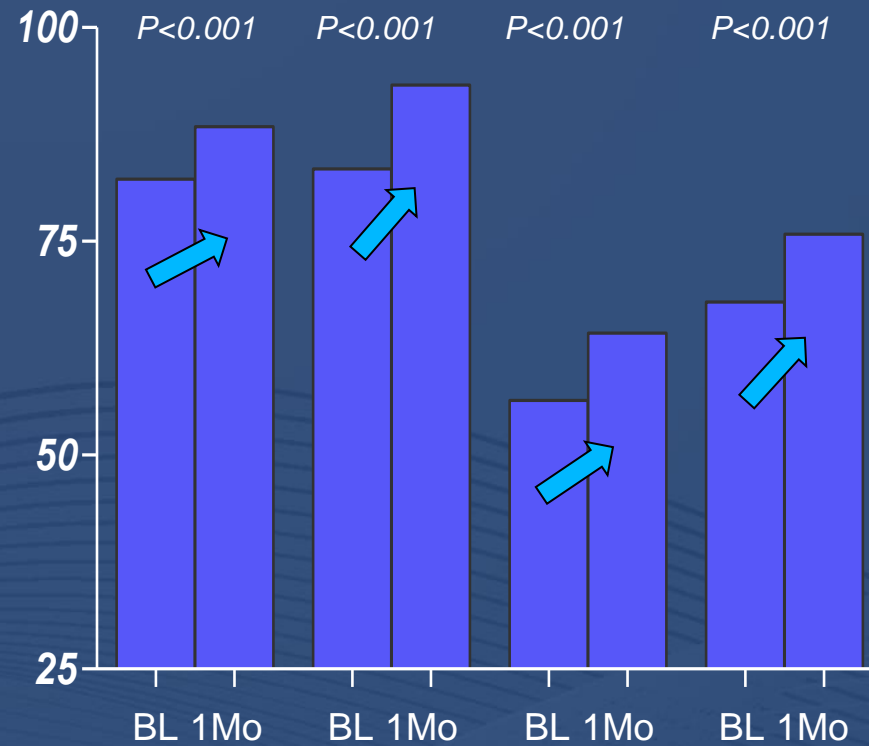

Physical Limitation
Angina Frequency
Quality of Life
EQ-5D VAS

Between group differences over time

	PCI strategy	MT strategy	Difference between PCI and MT strategy (95% CI)*	P value
SAQ physical limitation				
1 mo	90.00 ± 15.66	88.38 ± 17.11	-3.354 (-5.605 – -1.104)	0.004
6 mo	92.22 ± 13.61	91.80 ± 14.32	-1.813 (-4.089 – 0.464)	0.118
12 mo	93.06 ± 11.96	91.77 ± 15.12	-2.309 (-4.710 – 0.092)	0.059
24 mo	94.84 ± 12.72	93.69 ± 12.74	-1.920 (-4.301 – 0.462)	0.114
36 mo	94.52 ± 12.86	93.54 ± 14.98	-1.813 (-4.827 – 1.201)	0.237
SAQ angina frequency				
1 mo	94.63 ± 10.54	93.31 ± 13.78	-2.635 (-4.604 – 0.665)	0.009
6 mo	96.00 ± 10.13	95.44 ± 9.98	-1.037 (-2.911 – 0.837)	0.277
12 mo	94.55 ± 11.18	95.33 ± 10.19	-0.154 (-2.163 – 1.855)	0.880
24 mo	97.31 ± 7.13	97.18 ± 7.65	-0.427 (-1.978 – 1.125)	0.589
36 mo	98.21 ± 5.32	97.38 ± 7.20	-0.981 (-2.480 – 0.518)	0.199
SAQ quality of life				
1 mo	66.16 ± 19.87	64.26 ± 19.65	-3.075 (-6.135 – -0.016)	0.049
6 mo	72.08 ± 17.54	69.74 ± 17.48	-3.336 (-6.444 – -0.227)	0.036
12 mo	72.19 ± 19.06	71.89 ± 16.6	-1.458 (-4.745 – 1.829)	0.384
24 mo	77.37 ± 17.43	75.91 ± 17.77	-2.136 (-5.738 – 1.465)	0.244
36 mo	78.26 ± 17.39	77.53 ± 16.69	-1.213 (5.004 – 2.577)	0.529

*The difference between the PCI and MT strategy groups was adjusted for baseline values.

Negative values indicate better outcomes with PCI strategy.

Substantial Improvement (%) of Angina over Time

Increase from baseline score of 10 points or more

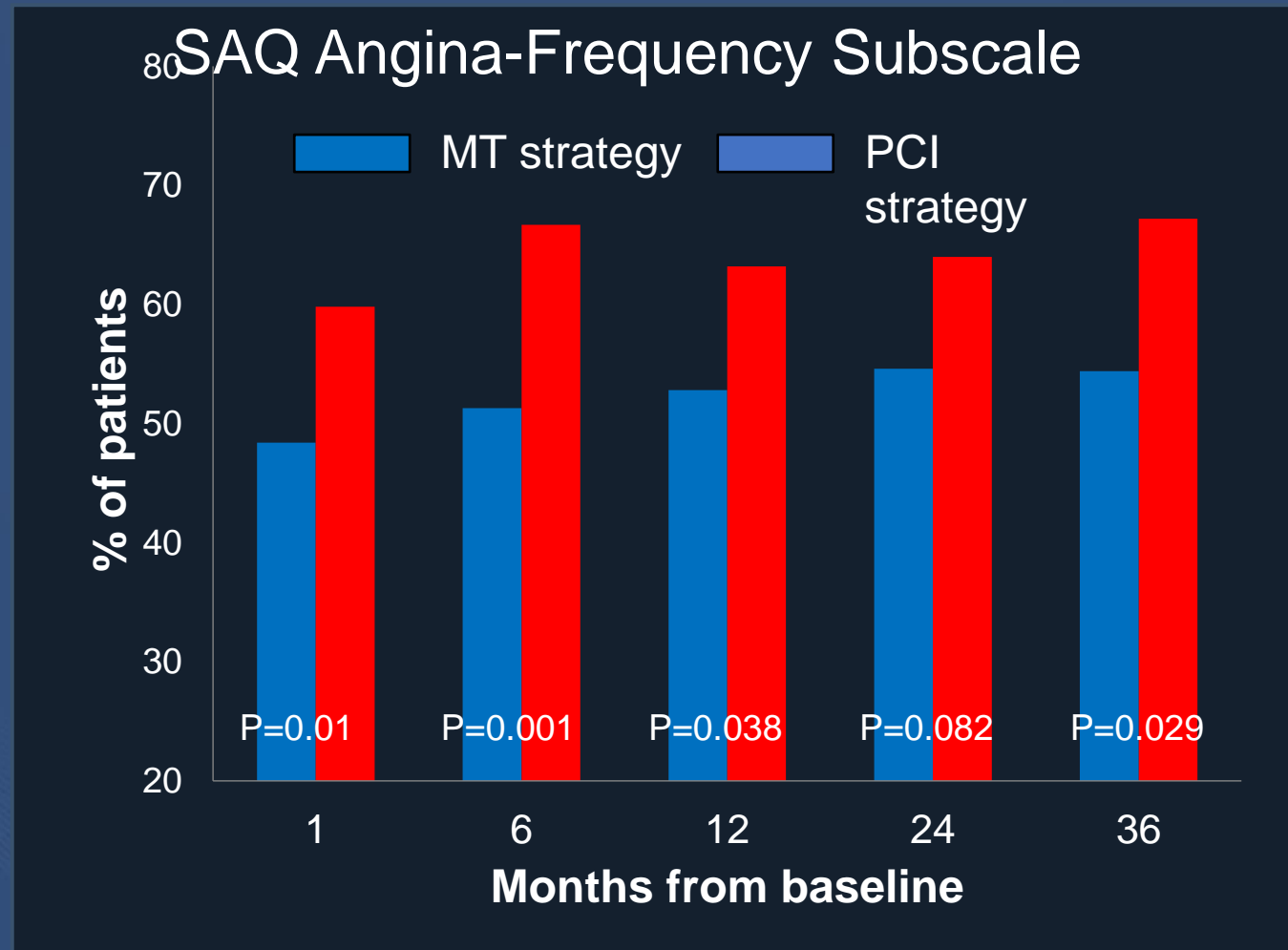

Subgroup Analysis

Subgroup	OMT <i>no. of patients with event/total no. (%)</i>	PCI	Hazard ratio (95% CI)	p value for Interaction
Overall	81/387 (20.9)	86/411 (20.9)	0.95 (0.70–1.28)	
Age				0.51
≥ 65 y	43/172 (25.0)	48/174 (27.6)	0.85 (0.56–1.29)	
< 65 y	38/215 (17.7)	38/237 (16.0)	1.05 (0.67–1.64)	
Sex				0.65
Male	63/315 (20.0)	71/342 (20.8)	0.91 (0.65–1.28)	
Female	18/72 (25.0)	15/69 (21.7)	1.07 (0.54–2.13)	
Diabetes				0.45
Yes	29/133 (21.8)	32/132 (24.2)	0.80 (0.48–1.32)	
No	52/254 (20.5)	54/279 (19.4)	1.03 (0.70–1.50)	
Previous myocardial infarction				0.77
Yes	6/34 (17.6)	9/45 (20.0)	0.83 (0.30–2.34)	
No	75/353 (21.2)	77/366 (21.0)	0.96 (0.70–1.32)	
Acute coronary syndrome				0.18
Yes	29/97 (29.9)	26/113 (23.0)	1.64 (0.88–3.05)	
No	52/290 (17.9)	60/298 (20.1)	0.82 (0.57–1.19)	
Typical chest pain				0.56
Yes	65/278 (23.4)	64/311 (20.6)	0.91 (0.64–1.29)	
No	16/109 (14.7)	22/100 (22.0)	1.63 (0.85–3.11)	
Ejection fraction				0.44
≥ 50%	60/321 (18.7)	63/332 (19.0)	0.91 (0.64–1.30)	
< 50%	21/66 (31.8)	23/79 (29.1)	1.21 (0.67–2.19)	
Multi-vessel disease				0.39
Yes	69/286 (24.1)	69/301 (22.9)	1.01 (0.72–1.41)	
No	12/101 (11.9)	17/110 (15.5)	0.70 (0.33–1.47)	
CTO located in the left anterior descending artery				0.98
Yes	29/161 (18.0)	34/183 (18.6)	0.93 (0.57–1.53)	
No	52/226 (23.0)	52/228 (22.8)	0.94 (0.64–1.38)	

0.1 10

OMT Better

PCI Better

Per Protocol Analysis

Noninferiority Test for Primary End Point at 3-Year

Per-Protocol Population

Estimated 3-year Event Rate OMT: 22.3% PCI: 19.0%

Prespecified non-inferiority margin: 0.7

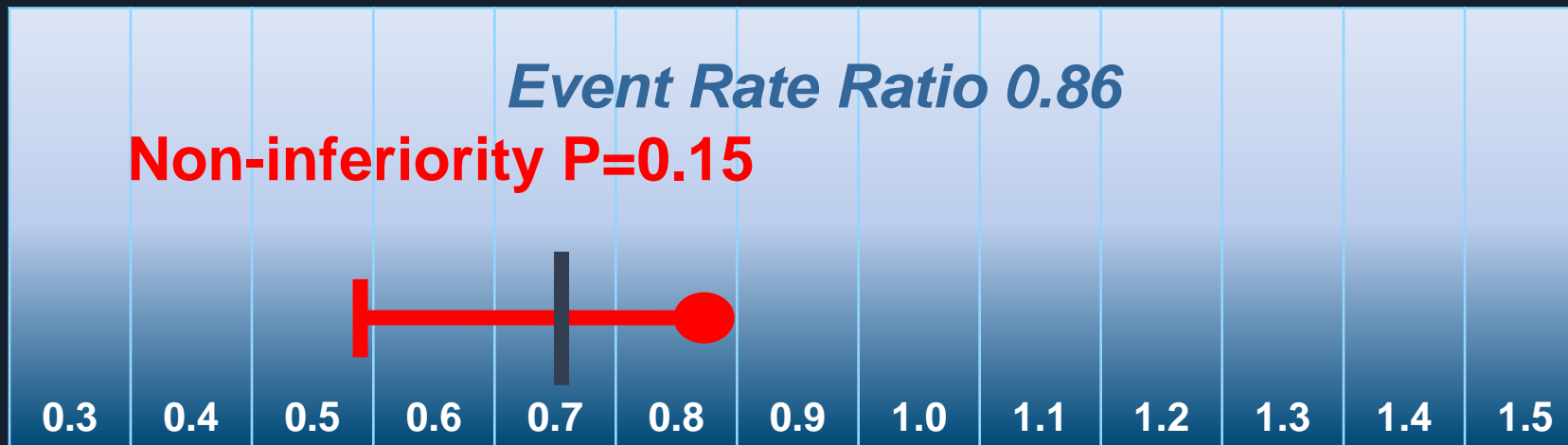

Event Rate Ratio of 3-year MACE rate (PCI/OMT)

Lower 1-sided 97.5% CI

Primary End Point

(Death, MI, Stroke, Any Repeat Revascularization)

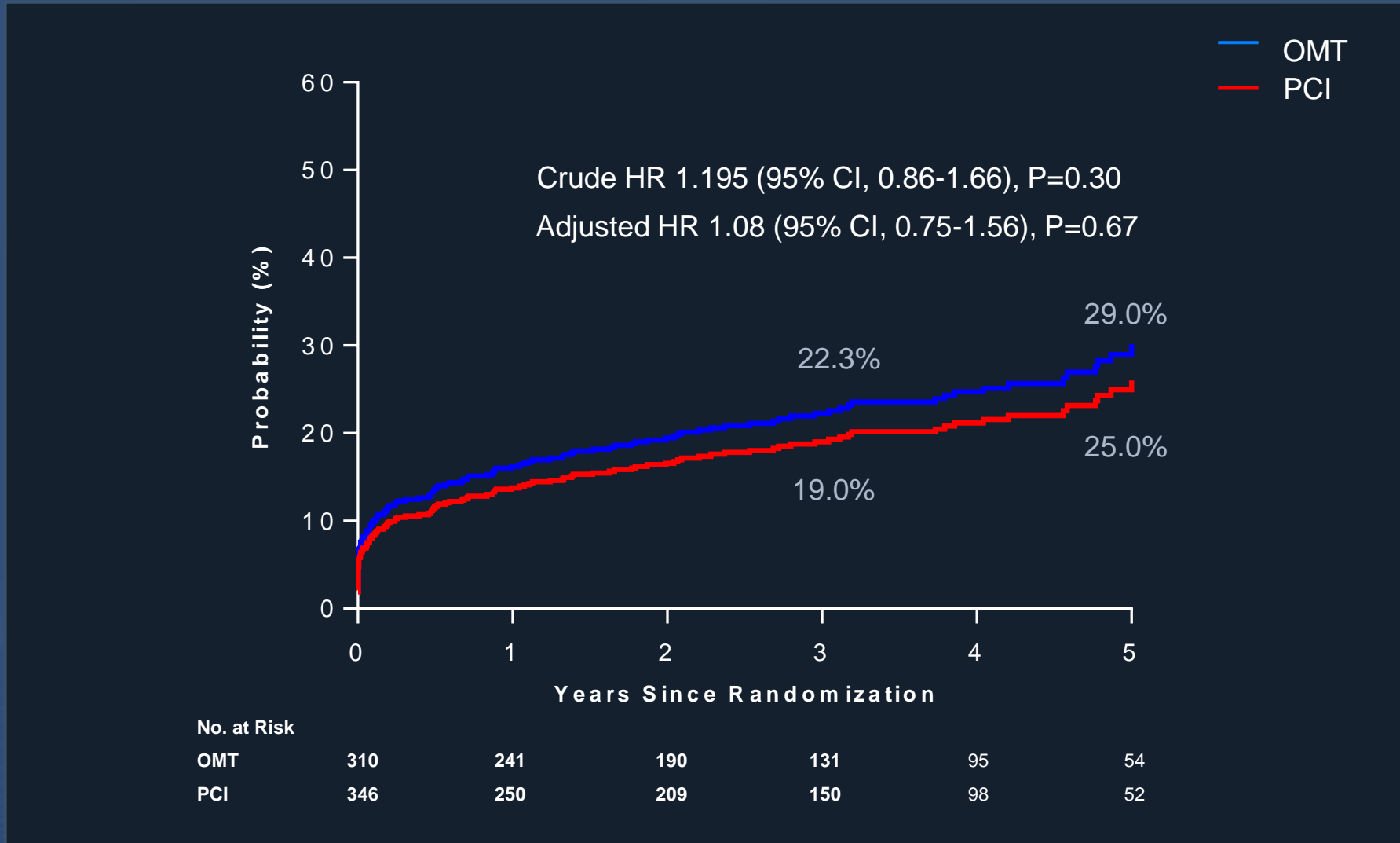

As Treated Analysis

Noninferiority Test for Primary End Point at 3-Year

As-Treated Population

Estimated 3-year Event Rate OMT: 23.1% PCI: 17.1%

Prespecified non-inferiority margin: 0.7

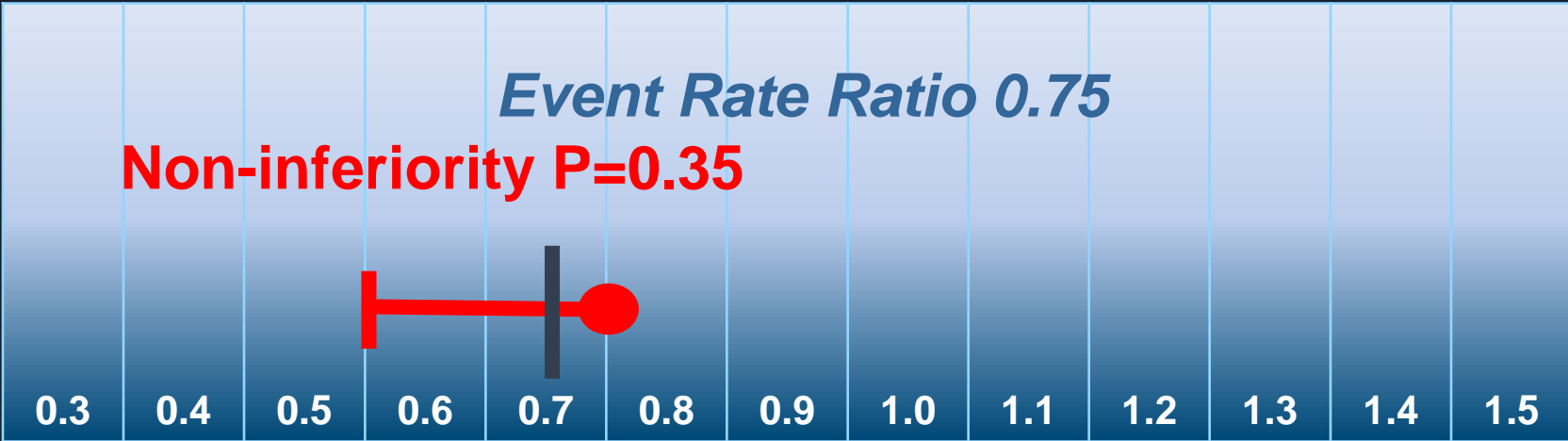

Event Rate Ratio of 3-year MACE rate (PCI/OMT)

Lower 1-sided 97.5% CI

Primary End Point

(Death, MI, Stroke, Any Repeat Revascularization)

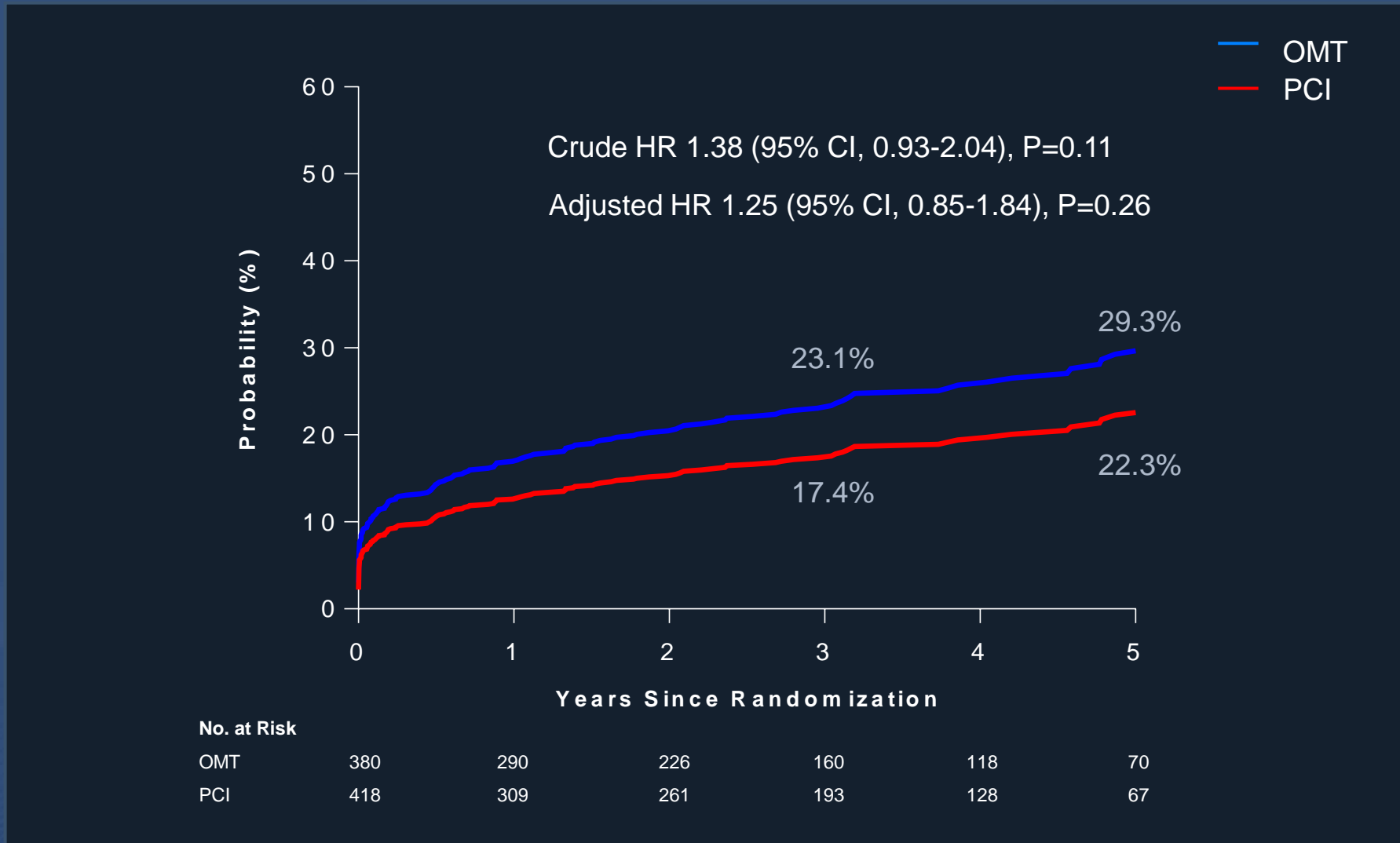

Primary End Point

(Death, MI, Stroke, Any Repeat Revascularization)

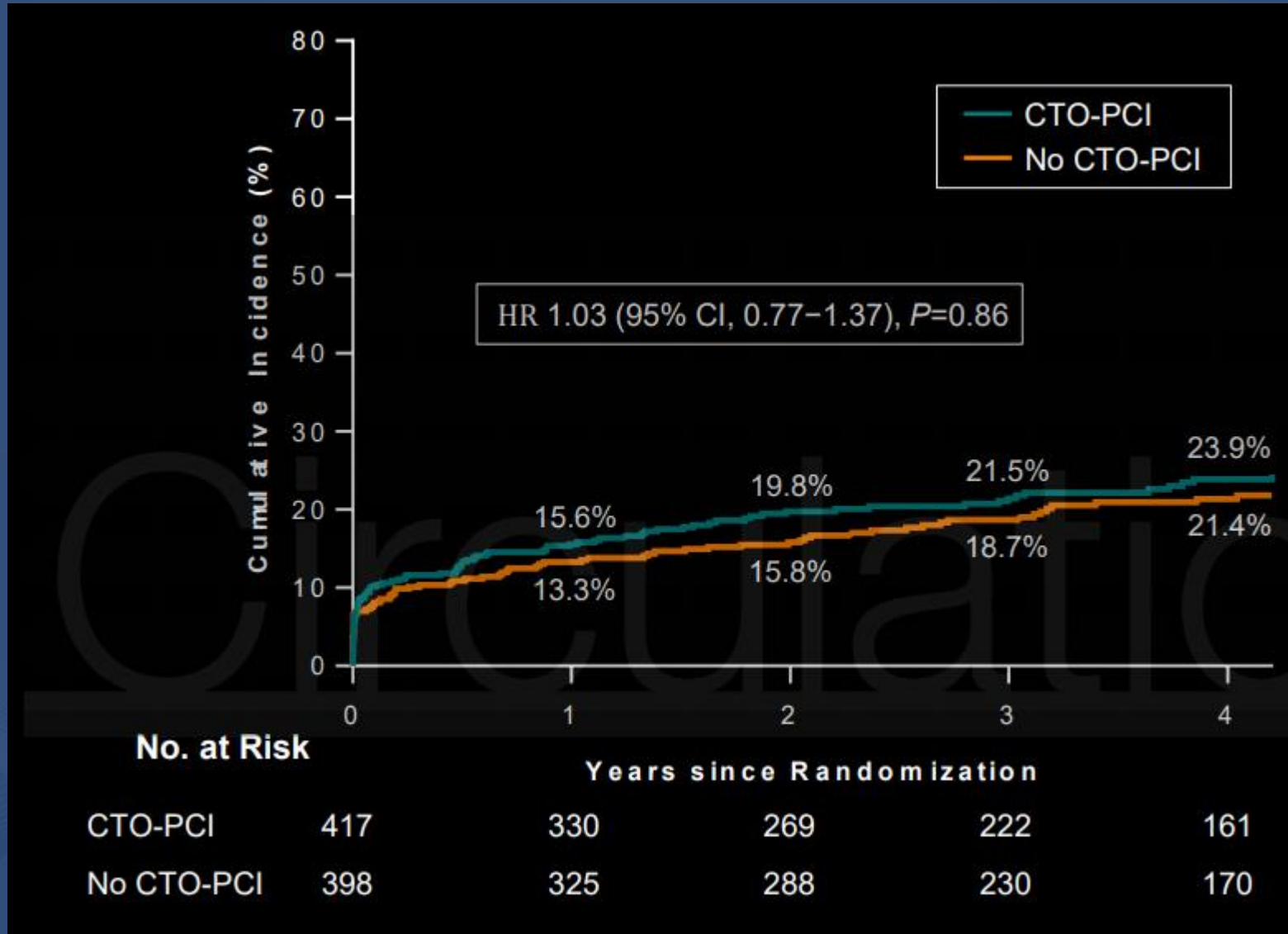

Intention-to-Treat Analysis

	CTO-PCI (n=417)	No CTO-PCI (n=398)	Crude HR (95% CI)	P value
Primary endpoint Death, MI, stroke, or any revascularization	93 (22.3)	89 (22.4)*	1.03 (0.77-1.37)	0.86
Secondary endpoints				
Death	15 (3.6)	21 (5.3)	0.70 (0.36-1.37)	0.30
Cardiac cause	8 (1.9)	14 (3.5)	0.56 (0.24-1.34)	0.19
Noncardiac cause	7 (1.7)	7 (1.8)	0.99 (0.35-2.82)	0.99
Myocardial infarction	47 (11.3)	34 (8.5)	1.39 (0.90-2.15)	0.14
Periprocedural MI	41 (9.8)	30 (7.5)	1.37 (0.816-2.18)	0.19
Spontaneous MI	7 (1.7)	7 (1.8)	0.88 (0.30-2.57)	0.82
Stroke	6 (1.4)	10 (2.5)	0.61 (0.23-1.65)	0.33
Any revascularization	46 (11.0)	42 (10.6)	1.14 (0.75-1.73)	0.55
CTO vessel	33 (7.9)	30 (7.5)	1.13 (0.69-1.84)	0.63
Non-CTO vessel	29 (7.0)	23 (5.8)	1.34 (0.77-2.31)	0.30
Death, MI, or stroke	66 (15.8)	61 (15.3)	1.07 (0.75-1.51)	0.72
Cardiac death, MI, stroke, or any revascularization	86 (20.6)	82 (20.6)	1.02 (0.76-1.39)	0.88
Death, spontaneous MI, stroke, or any revascularization	64 (15.3)	69 (17.3)	0.91 (0.65-1.30)	0.59

The Assigned and Actually Treated Strategies

Primary endpoint analyses

Stratified by the assigned and actual strategy

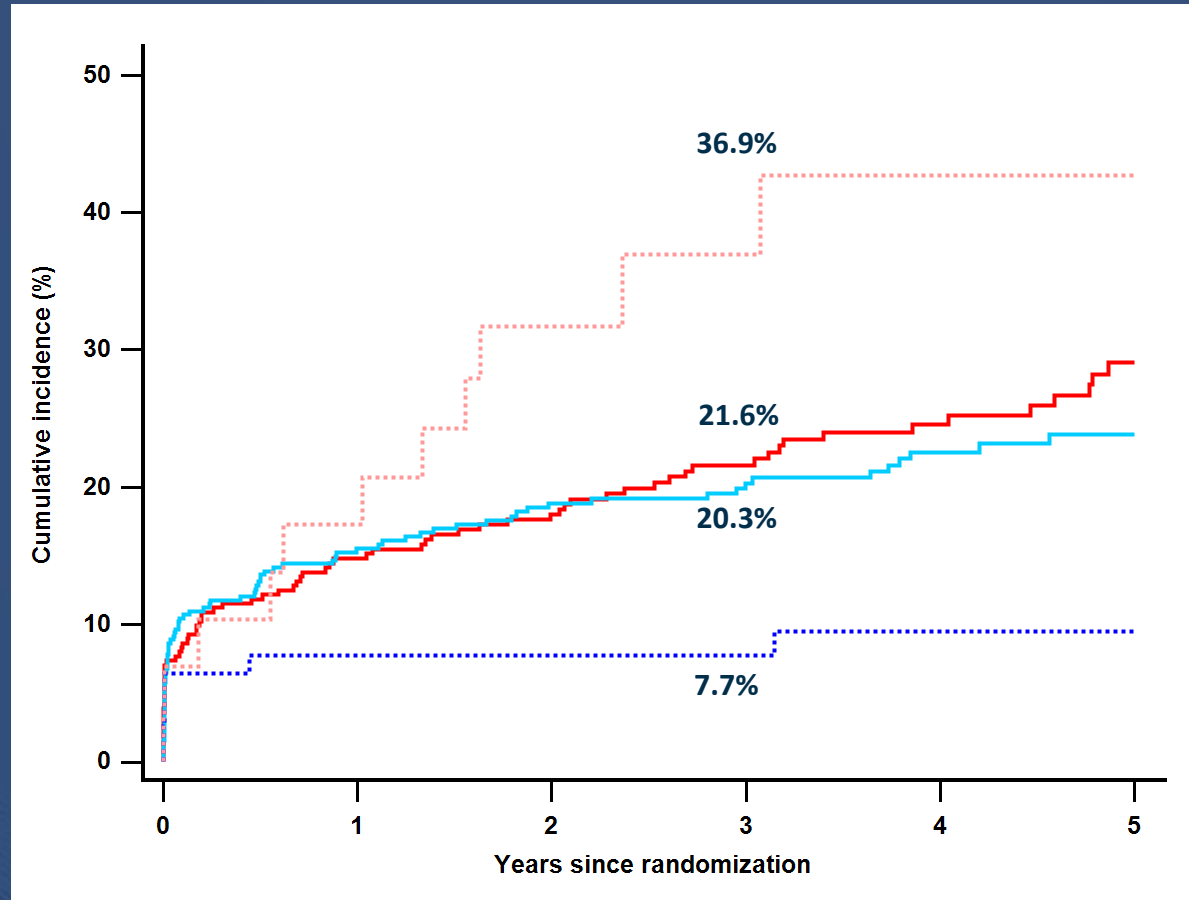

PCI to MT strategy

MT to MT strategy

PCI to PCI strategy

MT to PCI strategy

PCI to PCI	384	306	254	210	152	98
PCI to MT	29	25	16	13	10	8
MT to PCI	78	70	65	59	46	30
MT to MT	313	257	224	172	125	78

The Assigned and Actually Treated Strategies

	Estimated 3 Year Event Rate (Standard Error)	Adjusted HR (95% CI)	P Value
PCI to PCI	19.0% (2.1)	0.91 (0.61-1.34)	0.62
PCI to OMT	29.3% (5.8)	1.37 (0.80-2.34)	0.25
OMT to PCI	9.5% (4.2)	0.45 (0.19-1.09)	0.077
OMT to OMT	21.9% (3.3)	1 (Reference)	

Conclusion

- The DECISION-CTO trial is the first randomized clinical trial to compare the strategy of OMT alone with that of PCI in patients with coronary CTO.
- The ITT analysis showed that OMT as an initial strategy was non-inferior to PCI with respect to the primary endpoint of the composite of death, MI, stroke, or any revascularization at 3 years.
- The measures of health-related quality of life in the OMT and the PCI groups were comparable throughout the follow-up period

Conclusion

- However, SAQ angina frequency subscale is much better in terms of improvement more than 10 points in PCI arm, which suggest PCI strategy is more beneficial effect in angina control in CTO patients.
- However, despite statistical no difference, we did not provide firm conclusion for role of medical treatment strategy in the CTO patients due to early termination and lower enrolment than anticipated.
- There is a signal for role of medical treatment, but further randomized clinical trials are necessary.

3D wiring in CTO intervention

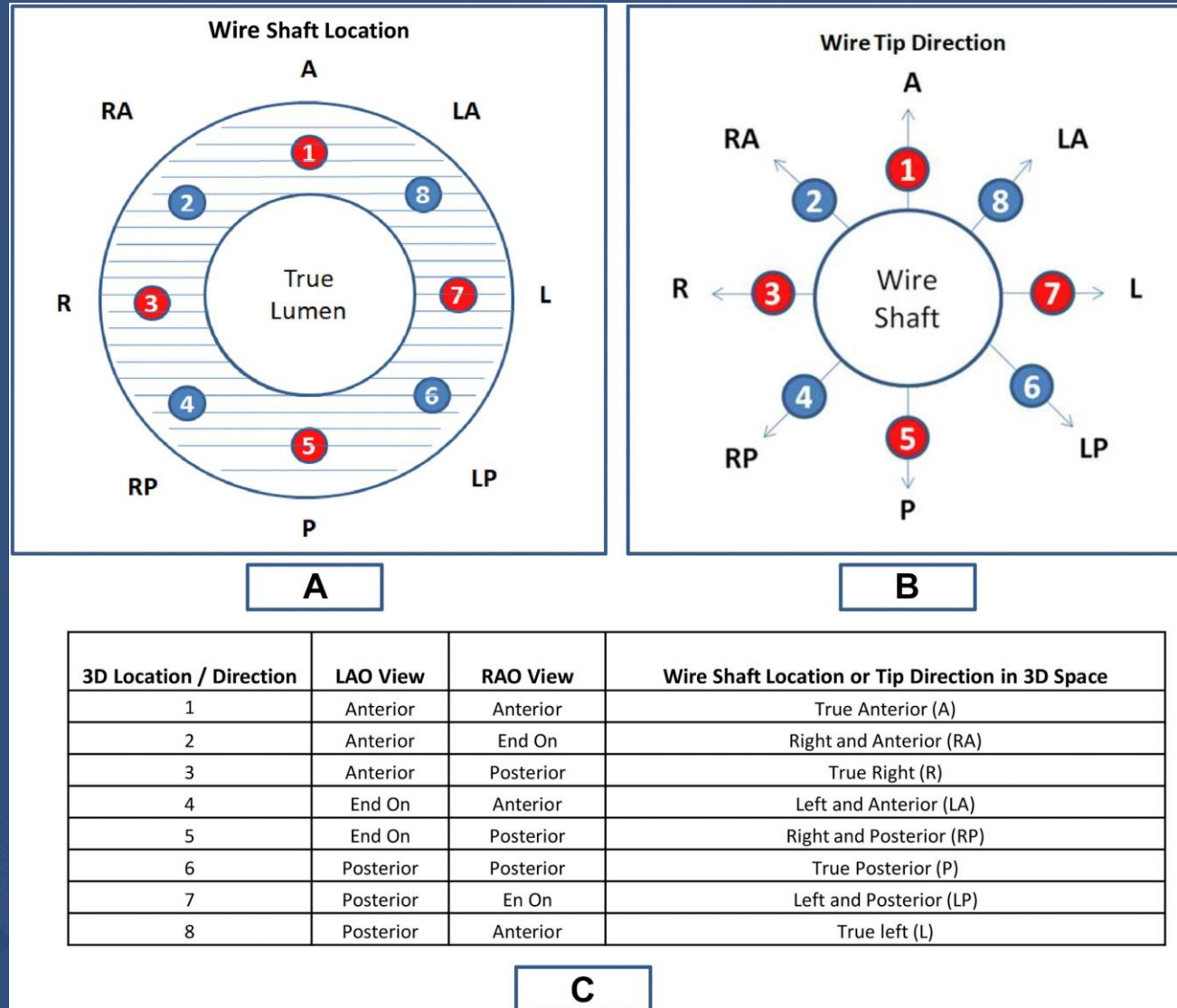

Efficacy and Feasibility of the 3D wiring for CTO PCI

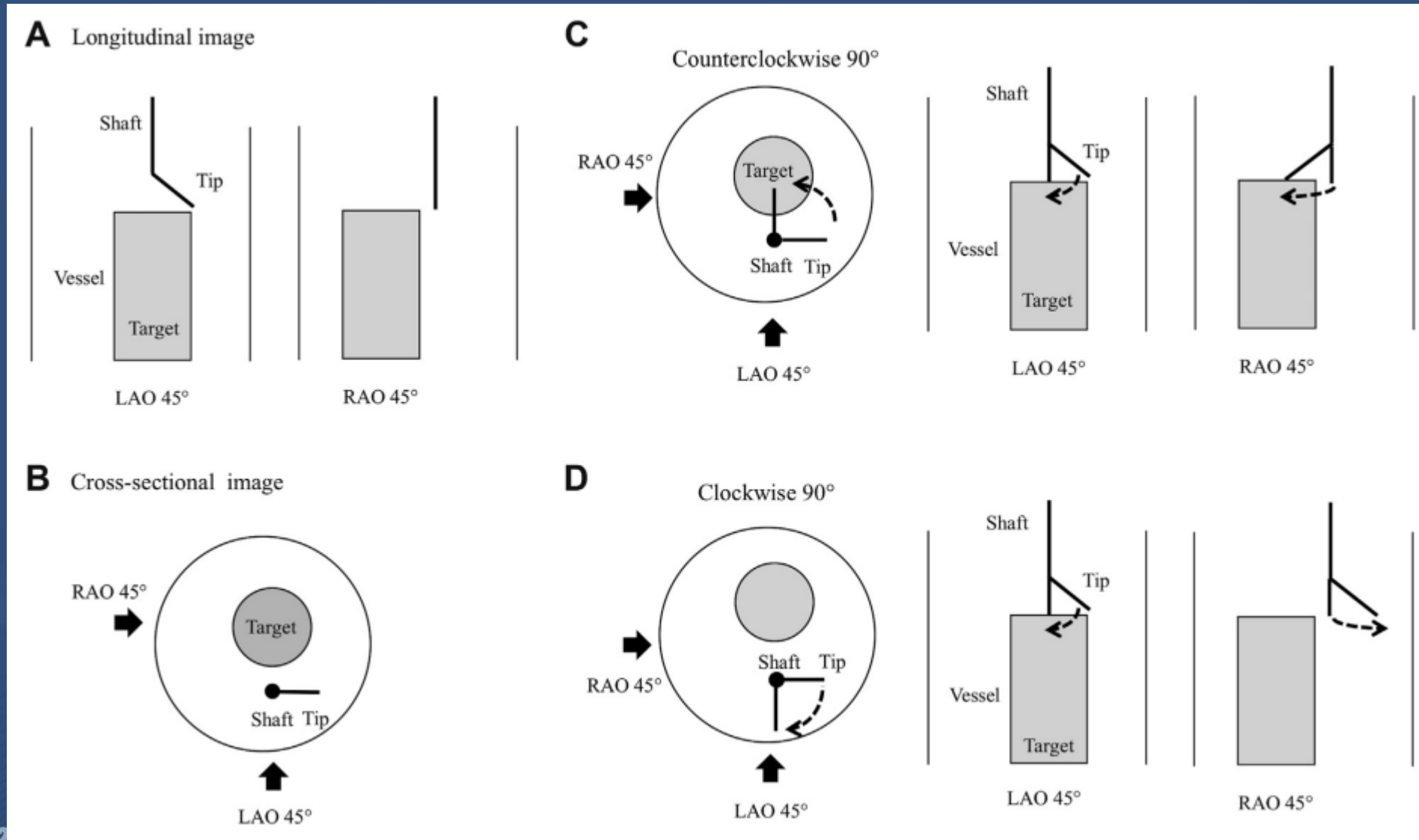

Efficacy and Feasibility of the 3D wiring for CTO PCI

D 9 possible patterns on the next image
When you rotate the detector to the perpendicular view at left,

- The shaft is in front of the target.
- The tip is facing away from the observer (behind).

A 64 rotation direction patterns to determine the degree of guidewire rotation within 45°.

Cross-sectional image

You are viewing the image of B from here.

C 9 possible patterns on the next image
When you rotate the detector to the perpendicular view at right,

- The shaft is behind the target
- The tip is facing toward the observer (front).

B 3D image rule

The direction of the object (shaft or tip) on the current monitor image facing the rotational direction of the X-ray detector	Z axis on the next monitor image
Same direction	The object is in front
Opposite direction	The object is behind

The words of right and left in bold are used for the decision of the same (in front) or opposite direction (behind).

Current X-ray monitor image

The rotational direction of the detector to the next image

Left ←
(From LAO to RAO)

Z axis on the next image (D)
The shaft (**left**) is in front.
The tip (**right**) is behind.

The shaft is on the **left** for the center of the target.
The tip is directed to the **right**.

The rotational direction of the detector to the next image

→ **Right**
(From RAO to LAO)

Z axis on the next image (C)
The shaft (**left**) is behind.
The tip (**right**) is in front.

E Mental 3D image

Construct a mental 3D image with information that the shaft is behind and the tip is in front, which reveals that the tip should be rotated 45° in the clockwise direction.

F Mental 3D image

Construct a mental 3D image with information that the shaft is in front and the tip is behind, which reveals that the tip should be rotated 45° in the counterclockwise direction.

Efficacy and Feasibility of the 3D wiring for CTO PCI

Study Population

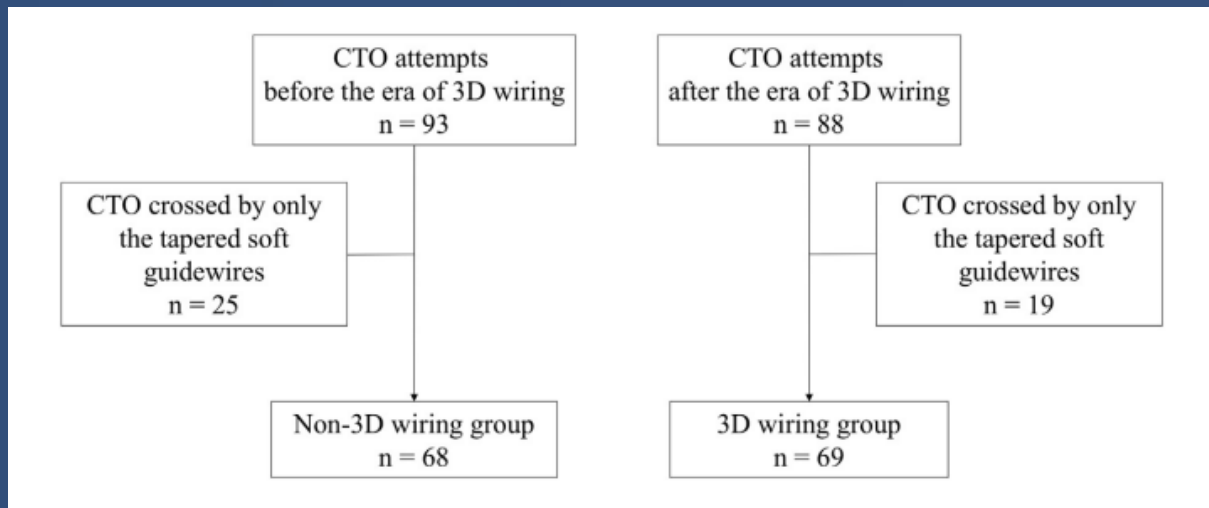

Flow Diagram of the Procedure in the Non-3D Wiring Group

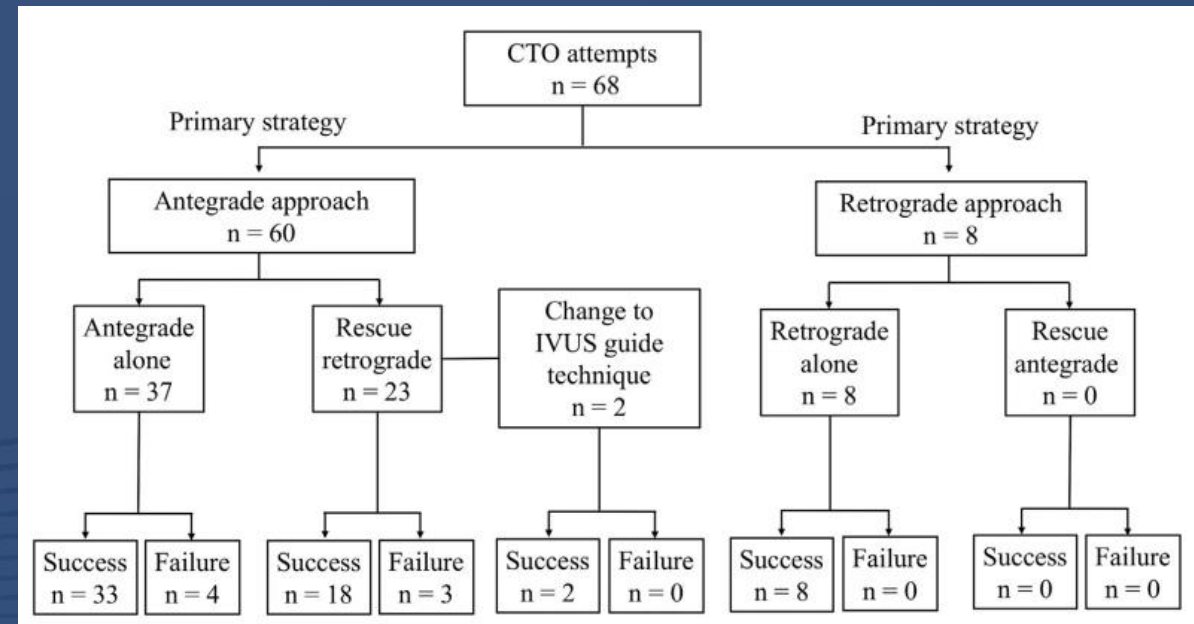

Efficacy and Feasibility of the 3D wiring for CTO PCI

Flow Diagram of the Procedure in the Non-3D Wiring Group

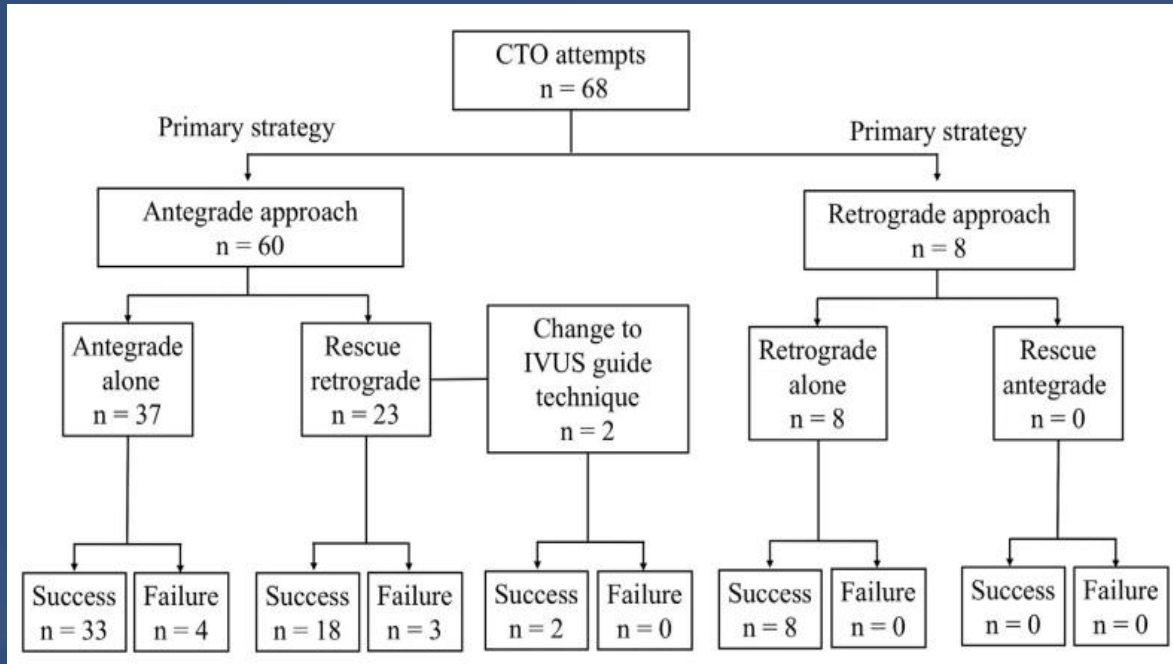

Flow Diagram of the Procedure in the 3D Wiring Group

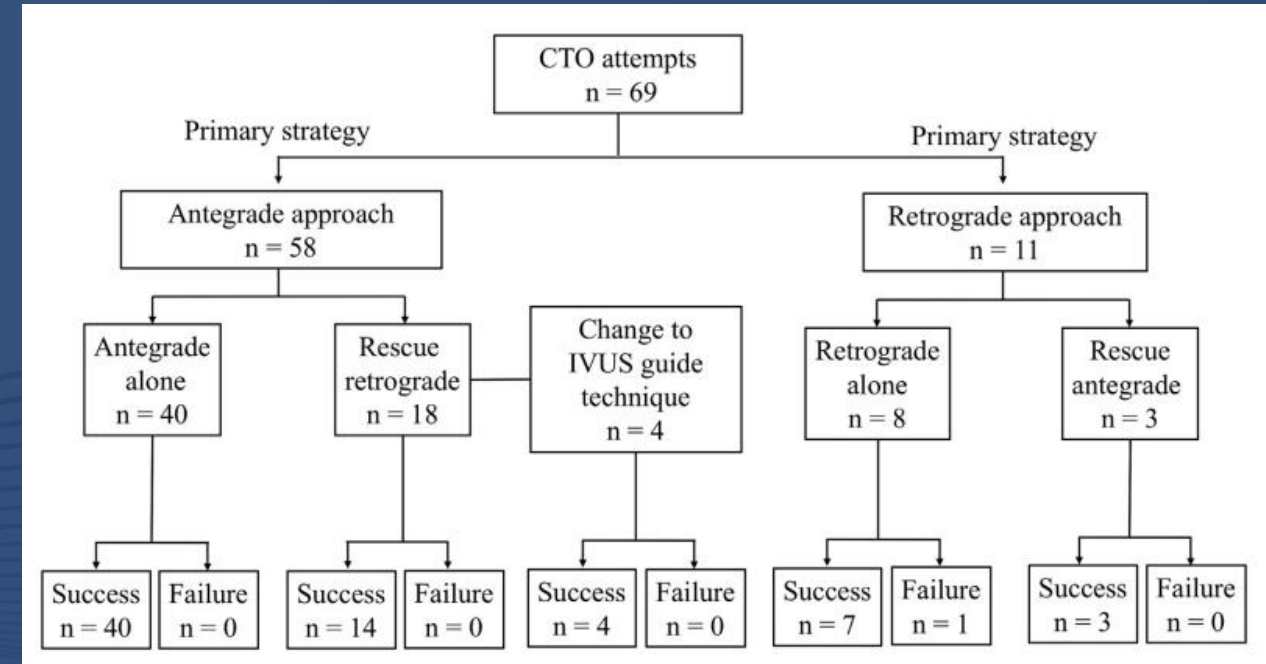

Efficacy and Feasibility of the 3D wiring for CTO PCI

